

Tricks of the Trade

Dave Porter, G4OYX with Carl Thomson, G3PEM

Readers will recall that last time we had reached the point by about 1950, where considerable strides had been made in the efficient combining of high power broadcast transmitters. This article explains the techniques.

MWT / Bartlett UK Patent No 743473

The work of MWT engineer, Hugh F Bartlett, was paramount to the development of the 'new' post-war approach of combining transmitters to achieve greater power output and reliability.

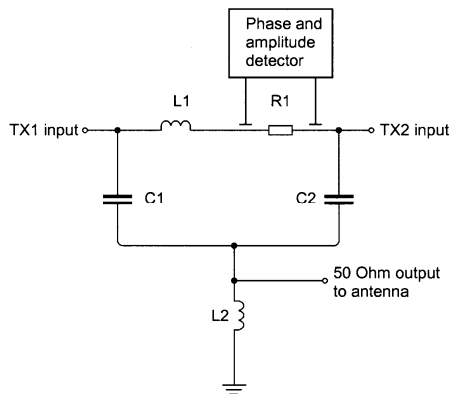

Figure 1. The Bridged-Tee Combiner.
 $XL1=XL2=XC1=XC2$

He devised what came to be known as the Bridged-Tee Combiner and the circuit of his patented invention to combine two transmitters is shown in Figure 1.

Mention was made last time that it was neat and component efficient; indeed there are only two inductors, two capacitors and a dummy (balancing) load.

The impedances of the reactive components and the resistive load are all the same as the specified transmitter output impedance. For example, for the Daventry Third Programme combiner for 150 kW at 647 kHz, these impedances were 220 Ohms.

Circuit Function

When the outputs from the two transmitters are of the same amplitude and in phase at the input to the network, there is no potential difference across the L1-R1 branch. Consequently there is no current flowing in it, and no power is dissipated in the load resistor R1. The two outputs pass through capacitors C1 and C2, respectively, and are paralalled at the input to the outgoing feeder; therefore, the power output in the feeder is twice that of each transmitter.

The series capacitive reactances of C1 and C2 are neutralised by the reactance of inductor L1 shunted

across the feeder so that each transmitter is correctly terminated by a resistive feeder.

If one transmitter fails the other continues to operate into a matched load with half the (remaining transmitter) power going out to the feeder, and the other half being dissipated in the balancing load. Of course now the actual radiated power is one quarter (-6dB) of that in the full power condition but, nevertheless, the service is still on the air.

In the following two sections are detailed the conditions in a series of circuits that "break-down" the components to illustrate the action of the combiner in the balanced condition *i.e.*, with both transmitters working with 50 Ohm loads etc.

Balanced operation

The L1-R1 branch is not shown as, in the balanced condition, no current is flowing and the circuit is redrawn as Figure 2a. By using series to parallel conversions of the reactive components it can be redrawn as Figure 2b as an exact equivalent of Figure 2a. Then by converting the two parallel sections 2L2 and 2RF to series components, as in Figure 2c, the exact equivalence is retained. In this arrangement the series capacitive and inductive reactances cancel out, giving a pure resistive loading (as in Figure 2d) of 50 Ohms per transmitter.

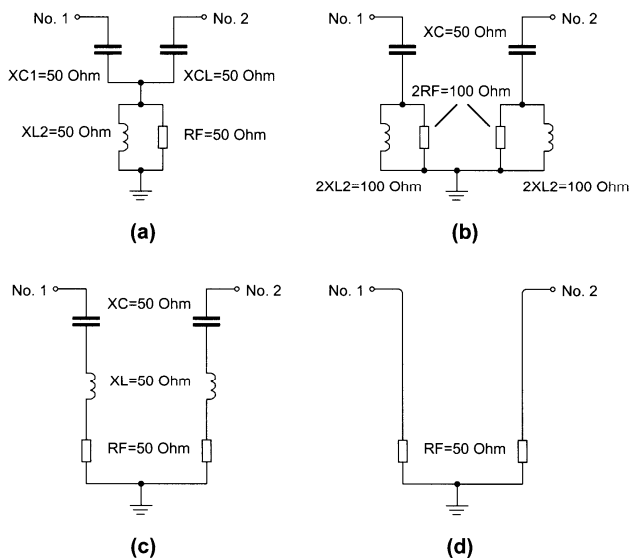

Figure 2. Breakdown of the bridged "T" network in the balanced condition

This shows that, in the parallel combined condition, each transmitter is correctly matched and all the power appears in the output feeder.

If the outputs of the two transmitters are not of the same amplitude, or not in phase, there will be current in the branch L1-R1 and power will be dissipated in the load R1. A device that indicates power in the load is essential for the trimming of both amplitude and phase. When a minimum, preferably zero, indication is obtained the tune-up is complete.

Single transmitter operation

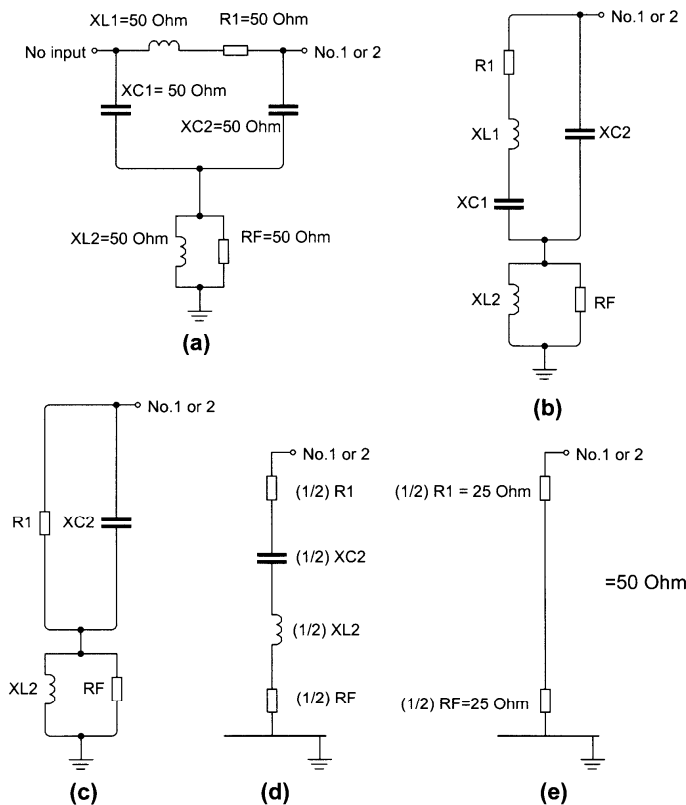

Figure 3. Breakdown of the bridged "T" network with one transmitter off

Referring now to Figure 3, the function of the Bridged Tee Combiner can be seen for situation where only one transmitter is working.

As before Figure 1 has been reproduced as Figure 3a but showing no power input on TX 1 port.

In Figure 3b the components have been rearranged to show more clearly that the reactances of L1 and C1 cancel out to give the circuit of Figure 3c. The parallel components of Figure 3c have been converted to their series equivalent in Figure 3d, which shows that the reactive components cancel out giving the equivalent circuit of Figure 3e. So it can be seen that the power of the one remaining transmitter is divided between the balancing load and the 50 Ohm feeder.

It is interesting to note that the failure of one transmitter does not affect the loading of the other and, in addition, should there should be a v.s.w.r. on the feeder, say from an iced-up antenna, the ratio of power radiated to power loss depends on the mismatch, but transmitter loading is unaffected. This is useful in unstaffed, remote installations.

More than two transmitters in parallel

In addition to the Daventry twin system, Bartlett devised a multi-input combiner, and this was first used in a broadcast situation for triplexed 660 W MWT MF transmitters at, for example, BBC Brighton, Barnstaple, and Redmoss to combine to provide 2 kW for the Home Service. This technique ensures maximum reliability in remote areas.

The author saw the next generation of triplexed sets at Brookman's Park in 1978 for Radio One (1089 kHz) and Radio 2 (909 kHz). Here three 50 kW transmitters were combined. The triplexer circuit is shown as Figure 4.

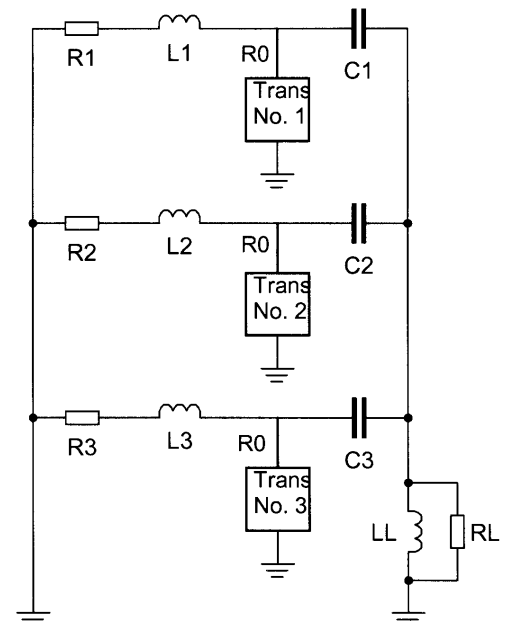

Figure 4. Bridged "T" paralleling network for more than two transmitters. R_0 =transmitter output impedance= R_L =feeder impedance; $R_1=R_2=R_3$; $L_1=L_2=L_3$; $C_1=C_2=C_3$. The circuit values are given in Table 1.

Essentially with all three transmitters on, the output is 150 kW, with one transmitter dead it is 66kW (-3.5dB), and for two dead, 16 kW, (~-10dB). The author was in this precarious 16 kW situation after two of the Radio One service transmitters failed after a near-direct lightning strike to their Tee antenna!

A quad combiner was used at Moorside Edge from 1985 for the 200 kW 909 kHz Radio 2 (now 5 Live) service.

Item	Ohmic value in terms of R0	
	3 Transmitters	N Transmitters
R1	2/3	(N-1)/N
XL1	$\sqrt{2/3}$	$\sqrt{(N-1)/N}$
XLL	$1/\sqrt{2}$	$1/\sqrt{(N-1)}$
XC1	$-\sqrt{2}$	$-\sqrt{(N-1)}$

Table 1. Circuit parameters in Figure 4.

Circuit refinements

With some additional circuitry, it is possible to employ RF contactor switching and effectively by-pass the combiner. MWT did employ contactor switching in the Daventry system to maintain, after manual intervention, a -3dB output with a working unit rather than the "temporary" -6dB condition. However a break of a few seconds is sustained whilst the transmitter HT is suppressed to permit the changeover. Of course, a similar break is experienced on manual resumption of full power.

A BBC Head Office Transmitter Engineer, Henry Willis was charged, in the late 1960s, with updating the 100 kW stations at Start Point and Stagshaw for unattended operation. He built two 50 kW MF transmitters at each site and employed the MWT/Bartlett design in a slightly different way.

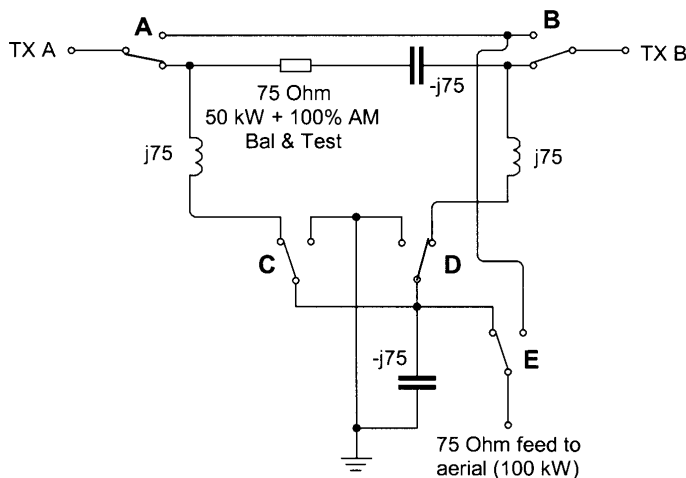

Figure 5. RF switching, The relay contacts (A-E) are shown in the de-energised position. These relays are Jennings RF10B vacuum relays.

Condition 1: Normal combination working; all relays de-energised

Condition 2: A-solo; B-test load; A,D,E energised; B,C de-energised

Condition 3: B-solo; A-test load; B,C,E energised; A,D de-energised

Figure 5 shows the Willis combiner. As with the MWT design, all the reactances etc are the same as the feeder impedance (in this case 75 Ohms) but he has reversed the positions of the inductors and capacitors.

This is advantageous for two reasons; first, the capacitors often used were oil-filled tank types, that is, one side was earthy. It could be isolated from ground, but this was not easy mechanically, and demanded additional engineering. With one of the capacitors connected across the output feeder then it was "groundable", the other capacitor (in series with the balancing load) was, of course, still "up-in-the-air".

The second advantage was that shunt capacity across the output helps in the suppression of second and higher harmonics, always worth remembering! The availability of high power rated ceramic and vacuum capacitors solved this problem in later installations.

The design also used contactor switching and Figure 5 shows how it works.

Radio Caroline

Mention was made earlier of the importance of correct amplitude and phase, and to illustrate the fact, the author is indebted to Carl Thomson, G3PEM, for allowing reproduction of part of his lecture notes from his amateur radio club presentation about his life and times as an engineer on both Radio Caroline South and North.

G3PEM relates....

We were sent to the North ship and tasked with both wave-changing the transmitters from '199' (1520 kHz) to '259' (1169 kHz) and with increasing the output power by combining. There were two Continental Electronics 10 kW transmitters type 316B. The combiner was based on the Wheatstone Bridge circuit and was an American product using large diameter L's and vacuum C's. It was a pity that I never did keep a copy of the circuit....

Us three engineers worked over two nights and we used one transmitter exciter stage, fed a signal from the oscillator of TX 1 to the other (TX 2) oscillator, there was a special switch inside the transmitters that you could switch out to turn the oscillator into a buffer, then you used (these drives) to come up into the combiner which was a bridge circuit.

You fed in the transmitter on two ports which were connected to either side of the bridge. The bottom port went through a 50 Ohm load to earth and the top port was out to the ATU and then the aerial.

Provided the thing was in balance, the bottom port never had any RF out, all the power would go out of the top into the ATU and on to the aerial, about 18 kW. We lost about 2 kW across the combiner

If you lost a transmitter then you would go down to 5 kW, as 5 kW would go to the aerial and 5 kW to the load, due to the unbalanced state.

During the conversion from 10 kW to 20 kW we should have been transmitting 20 kW on the first night but we got the phasing wrong. We had the wrong transmitter driving and we were putting a lot of power into the load and nothing into the aerial.

We realised we were getting a bit tired and not thinking straight, but the next night we came to it right away. The notation on the American diagrams was interpreted wrongly, remember this was the 1960s and everyone

used different symbols. Once this was suspected then the combiner was turned through 180 degrees and re-connected, problem solved.

The combiner was never used successfully on the southern ship but on the northern ship, once it was working it was very successful.

Those tales from G3PEM remind the author of similar "nightshifitis" problems where totally perplexed night shift engineers would poke about for hours only to find that the wide-awake day shift would sort it in five minutes!

The author has been unable to find any Internet reference to the USA-produced MF combiner under its alleged name of "Magic-Tee"; the only references are to a microwave design, so whether the Radio Caroline unit was modelled exactly on the patented MWT design cannot be clarified.

As Carl said, it's a shame he did not have a circuit.

Sunshine 855

The author had occasion to employ a Bridged-Tee combiner to parallel a pair of RCA/BBC ET4336 transmitters to 500 W output. Prior to this, a ferrite combiner had been used (to be described in the next ToTT).

The Henry Willis circuit (shown as Figure 6) was used and the values at 855 kHz for 125 Ohms were $L1$ and $L2=23.2 \mu\text{H}$ and $C1$ and $C2=1490 \text{ pF}$.

An L network was used to convert from 125 Ohms to 50 Ohms to suit the feeder. The losses across the combiner were minimal and, to check for balance, a Mullard FX1588 ferrite ring was over-wound with 10 turns of wire connected to a BNC socket and then on to a scope. The connecting wire between $C1$ and $R1$ went through the middle of the ring supported by glass fibre copper-less pcb material. The phasing and power outputs of the ETs were adjusted for minimum scope trace.

As a test during the setting up, the author used a VFO to sweep the ports and look at the input impedances and the power appearing in the load. The combiner was "good" for a bandwidth of 40 kHz from nominal frequency and, as such, was assured that no sideband cutting would ensue as the 'Q' was low.

Next time

Next time in ToTT we will look at the BBC 500 W ferrite combiner and the HMGCC Crowborough / FCO CED Orfordness 500 kW systems.

On a lighter note, the Daventry Third Programme frog and ATU incidents will be described and, in addition, following a query, the postscript to OSE5 will be revealed.

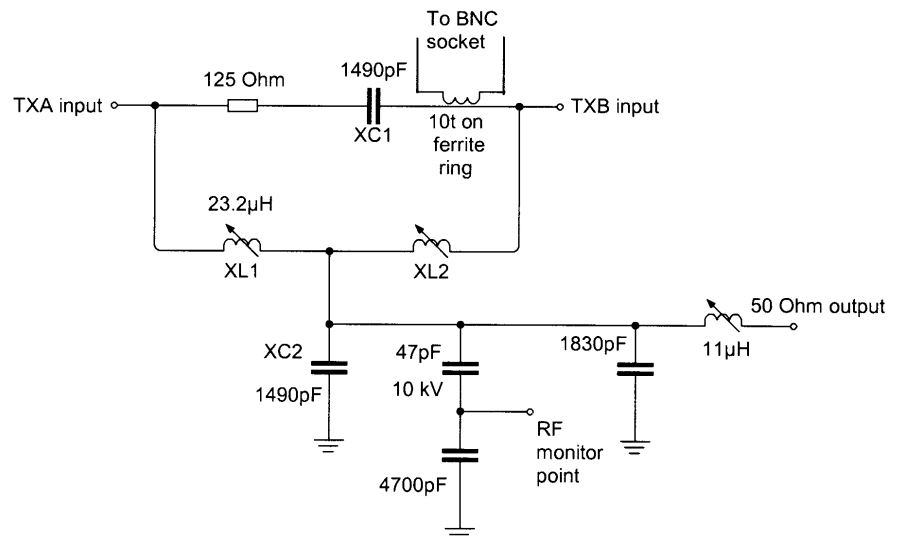

Figure 6. Circuit diagram of the combiner used with two ET4336 transmitters

~ ~ ~



This photograph shows the Zo 220 Ohm overhead feeder from the T3 building on Borough Hill to the mast at Dodford, some 2.13 km (7000 feet) away. There was a loss at 647 kHz of 15 kW on this run!