

**EQUALISER AMPLIFIERS AM1/561 AND AM1/562**

## AM1/562

**Introduction**

The AM1/561 and AM1/562 are afterglow and aperture correction amplifiers and normally form part of the Video Processing Amplifier AM1M/560. Each amplifier applies aperture correction and 6 stages of afterglow correction to a 0.7 volt non-composite video signal. The aperture correction controls are mounted on the front panels but the afterglow correctors are adjusted with a screwdriver through holes in the panels. The AM1/561 consists of one amplifier and a power supplier; the AM1/562 has two identical amplifiers and no power supplier. The AM1/562 is normally used with an AM1/561 from which it draws power.

The amplifiers are built on to CH1/46A chassis with index pegs 27 and 32 (AM1/561) and 27 and 31 (AM1/562).

**General Specification**

|                                     |                      |
|-------------------------------------|----------------------|
| <i>Input</i> (non-composite video)  | 0.7 V p-p            |
| <i>Input Impedance</i>              | 3 kilohm             |
| <i>Output</i> (non-composite video) | 0.7 V p-p            |
| <i>Output Impedance</i>             | less than<br>0.5 ohm |
| <i>Load Impedance</i> (minimum)     | 150 ohms             |
| <i>Afterglow Correction</i>         | 6 dB per<br>section  |

*Afterglow Correction* (time constants)

|         |             |
|---------|-------------|
| 1 (TR1) | 0.2 $\mu$ s |
| 2 (TR2) | 0.4 $\mu$ s |
| 3 (TR3) | 0.9 $\mu$ s |
| 4 (TR4) | 2.0 $\mu$ s |
| 5 (TR6) | 4.0 $\mu$ s |
| 6 (TR5) | 9.0 $\mu$ s |

|                                       |                                       |
|---------------------------------------|---------------------------------------|
| <i>Aperture Corrector Boost</i> (max) | 12 dB                                 |
| <i>Frequency of Max Boost</i>         | 7 MHz                                 |
| <i>Operating Temperature Range</i>    | 10°C to 45°C                          |
| <i>Mains Power Requirements</i>       | 30 mA at<br>240 V $\pm$ 10%,<br>50 Hz |
| <i>Weight</i>                         | 2 $\frac{3}{4}$ lb                    |

**Circuit Description**

The circuit diagram of the AM1/561 is given in Fig. 1 and of the AM1/562 in Fig. 2.

The six afterglow corrector stages, TR1—TR6, are all similar except for the time constants in the emitter circuits. Buffer amplifier TR7 drives emitter follower TR8 which feeds the aperture correction

circuit. The main signal path through the corrector is via the delay line L1 to the first half of TR9 and thence to output compound emitter follower, TR10/TR11.

DL1 is an unterminated delay line in which the delayed output is also reflected back to the input. Thus the waveform at the R26 end is the input plus the reflected waveform. Low frequencies are unaffected but, as the frequency approaches 7 MHz the input and reflected waveforms add to produce a maximum boost in amplitude of about 12 dB.

With the slider of the aperture corrector set to the R28 end (its minimum position) both halves of TR9 receive exactly the same signal and there is no correction. As the slider of the control is moved towards the junction with R26, more and more of the boosted h.f. components of the signal are applied to the second half of TR9.

These boosted h.f. components are injected into the first half of TR9 via the common emitter circuit and they appear amplified but without inversion in the collector circuit. The main signal, fed to the base of TR9, appears amplified and inverted in the collector circuit. Thus, in the collector circuit of TR9, there appears the amplified and inverted main signal with its delayed h.f. components and also, from the second half of TR9, the amplified main signal with its boosted h.f. components. These all add together to give a main signal with sharpened leading and lagging edges. (Compare this with the process of Vertical Aperture Correction described in Instruction P.3. of *B.B.C. Engineering Practice.*)

**Maintenance**

Routine maintenance is not required but the following checks can be made occasionally.

1. In the power supply circuit, check that there is approximately 12 V across C21 and approximately 6 V across C17.
2. Feed in a Pulse and Bar signal and terminate the output at the oscilloscope terminals. Adjust R29 to give an overall gain of unity. Ensure that limiting does not occur.
3. Set the Pulse and Bar generator to give a 2T pulse and connect it via a 6-dB attenuator to the input of the amplifier. Each afterglow corrector should give, at its maximum setting, a 6-dB overshoot following the pulse.
4. With conditions as in test 4 but with all the afterglow correctors at their minimum setting, turn the aperture corrector control to its mid position; the overshoots at the edges of the pulse should be of approximately equal amplitude.

**References**

1. Designs Department Specification No.8.298(68)
2. Designs Department Specification No.8.299(68)

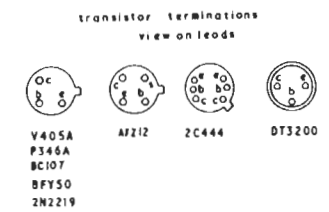
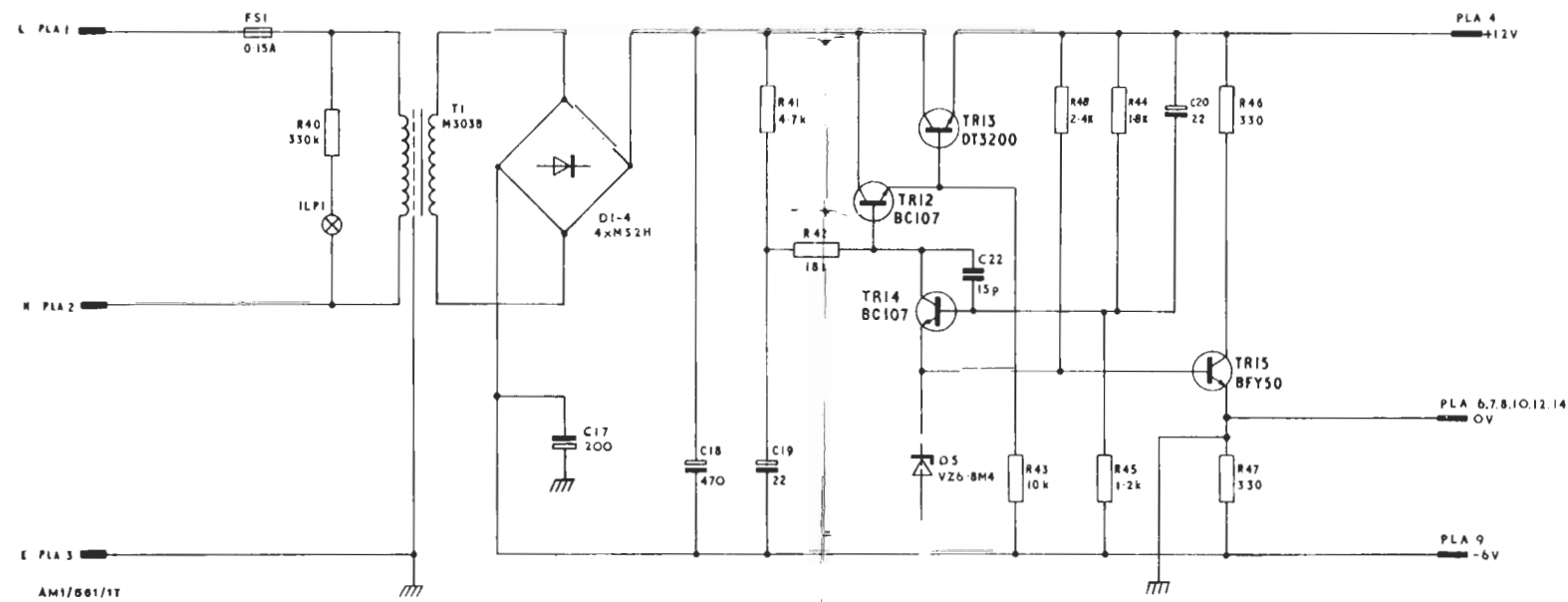
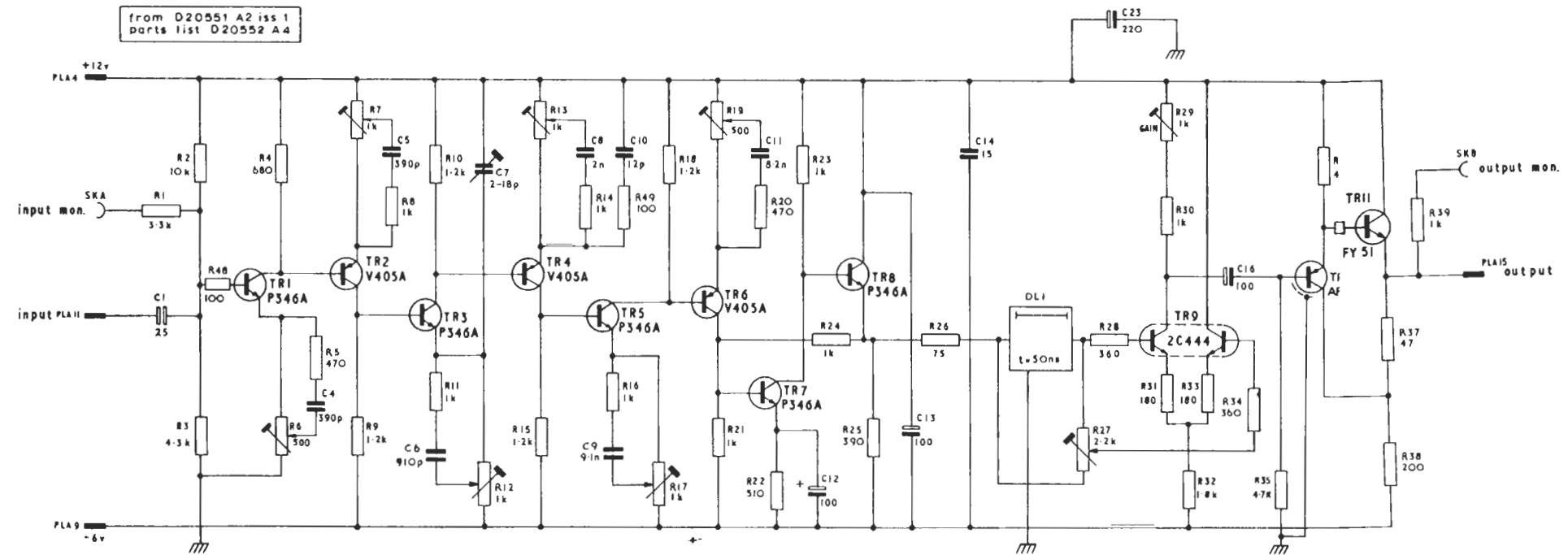

Fig.1. Circuit of Equaliser Amplifier AMI/561