

SIGNAL SUPPRESSION UNIT RC4C/501

The RC4C/501 is designed to be used in conjunction with a receiver type RC4/501. If the signal input to the associated receiver falls below a preset level, a relay in the RC4C/501 operates. Connections made to the relay can be such that the video and/or sound output of the receiver is muted when operation occurs.

The unit is built in a metal box and is complete with mains-operated power supplier. The signal input and the relay's external connections are made via an eight-pin plug which is mounted on the rear of the box. The mains input is made via a flying lead from the unit.

General Specification

Signal input	A feed of a.g.c. voltage from the associated receiver.
Power requirements	240 volts, 50 Hz.
Power consumption	40 mA at 240 volts.
Size	229 mm (9 in.) high, 51 mm (2 in.) wide and 120 mm (4 3/4 in.) deep.
Weight	1.36 kg (3 lb).

Circuit Description

Fig. 1 is a circuit diagram of the unit. Until a signal is present the input transistors TR1 and TR3 are cut off, TR2 is conducting and relay RLA is de-energised. When a signal more negative than the preset level is applied to PLA7, zener diode ZD4 and transistors TR3 and TR1 conduct to energise relay RLA. The operating point of the relay is defined by zener diode ZD3 in the TR1 emitter circuit. When TR1 is not conducting the resistance of ZD3 is high. When the potential across the diode exceeds 4.7 volts its resistance falls very rapidly

Contact RLA-1 completes the energising circuit of relay RLB. Contacts RLB-1 and RLB-2, as well as resistors R10 and R11, are part of the vision and sound muting arrangements in the associated receiver.

The mains transformer has an 11-volt secondary winding. This feeds a voltage-doubler rectifier circuit to produce d.c. which is stabilised by zener diodes ZD1 and ZD2. Resistor RV1 sets the potentials of the positive and negative supply rails with respect to earth.

A mains switch, two fuses and an indication lamp are mounted on the front of the unit.

Setting-up Procedure

1. Make connections from PLA on the unit to the associated RC4/501 as follows:

<i>RC4C/501</i>	<i>RC4/501</i>
PLA1	to negative 18-volt line.
PLA2	via 1-megohm resistor to pin 1 of V10 in the A.G.C. Unit.
PLA5	via 1-megohm resistor to pin 1 of V5 in the RC1A/501.
PLA7	to slider of RV5, in the A.G.C. Unit.
Earth	to earth.

Note: PLA3 and PLA5 are not used.

2. Feed a signal to the RC4/501 and adjust the level to be that at which muting is required to operate.
3. Adjust RV1 in the RC4C/501 so that RLA is energised.
4. Check that the receiver is demuted if the signal input is increased by about 1 dB.

LPB 5/69

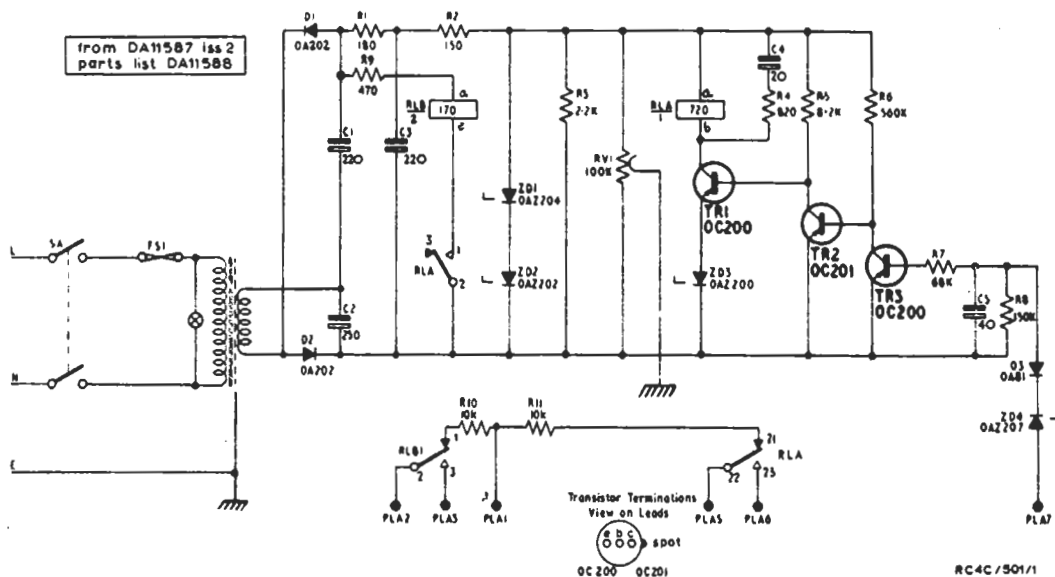

Fig. 1. Circuit of the RC4C/501

SECTION 10

SIGNAL SUPPRESSION UNIT RC4C/501

The RC4C/501 is designed to be used in conjunction with a receiver type RC4/501. If the signal input to the associated receiver falls below a preset level, a relay in the RC4C/501 operates. Connections made to the relay can be such that the video and/or sound output of the receiver is muted when operation occurs.

The unit is built in a metal box and is complete with mains-operated power supplier. The signal input and the relay's external connections are made via an eight-pin plug which is mounted on the rear of the box. The mains input is made via a flying lead from the unit.

General Specification

Signal input	A feed of a.g.c. voltage from the associated receiver.
Power requirements	240 volts, 50 Hz.
Power consumption	40 mA at 240 volts.
Size	229 mm (9 in.) high, 51 mm (2 in.) wide and 120 mm (4 3/4 in.) deep.
Weight	1.36 kg (3 lb).

Circuit Description

Fig. 1 is a circuit diagram of the unit. Until a signal is present the input transistors TR1 and TR3 are cut off, TR2 is conducting and relay RLA is de-energised. When a signal more negative than the preset level is applied to PLA7, zener diode ZD4 and transistors TR3 and TR1 conduct to energise relay RLA. The operating point of the relay is defined by zener diode ZD3 in the TR1 emitter circuit. When TR1 is not conducting the resistance of ZD3 is high. When the potential across the diode exceeds 4.7 volts its resistance falls very rapidly.

Contact RLA-1 completes the energising circuit of relay RLB. Contacts RLB-1 and RLB-2, as well as resistors R10 and R11, are part of the vision and sound muting arrangements in the associated receiver.

The mains transformer has an 11-volt secondary winding. This feeds a voltage-doubler rectifier circuit to produce d.c. which is stabilised by zener diodes ZD1 and ZD2. Resistor RV1 sets the potentials of the positive and negative supply

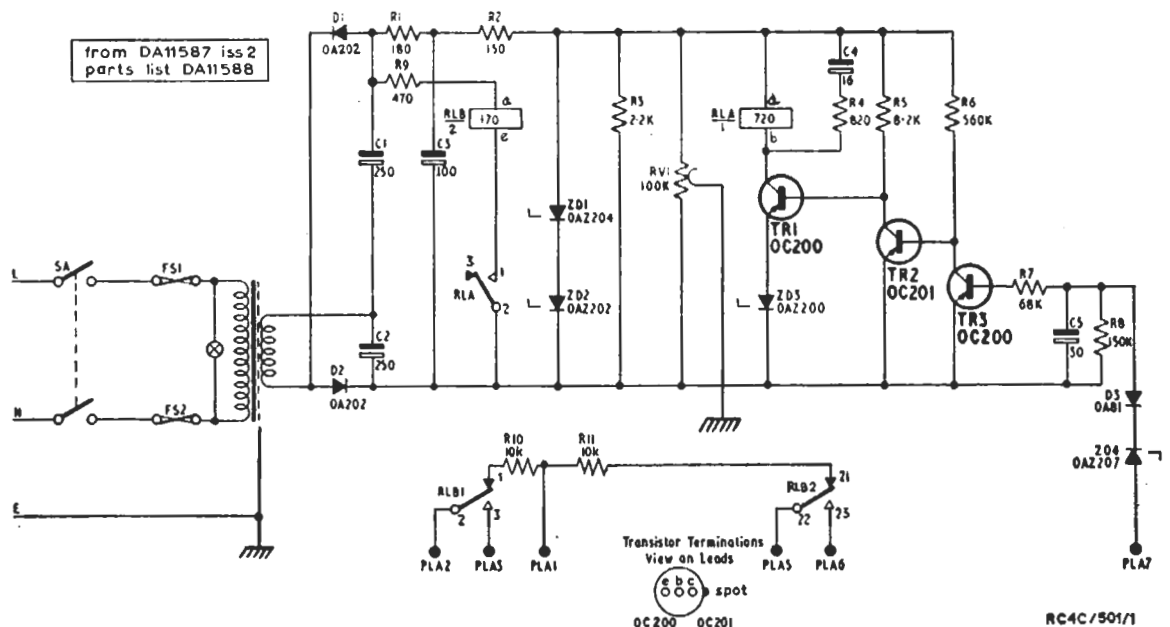

Fig. 1. Circuit of the RC4C/501

rails with respect to earth.

A mains switch, two fuses and an indication lamp are mounted on the front of the unit.

Setting-up Procedure

1. Make connections from PLA on the unit to the associated RC4/501 as follows:

RC4C/501

RC4/501

PLA1 to negative 18-volt line.

PLA2 via 1-megohm resistor to pin 1 of V10 in the A.G.C. Unit.

PLA5 via 1-megohm resistor to pin 1 of V5 in the RC1A/501.

PLA7 to slider of RV5, in the A.G.C. Unit.
Earth to earth.

Note: PLA3 and PLA5 are not used.

2. Feed a signal to the RC4/501 and adjust the level to be that at which muting is required to operate.
3. Adjust RV1 in the RC4C/501 so that RLA is energised.
4. Check that the receiver is demuted if the signal input is increased by about 1 dB.

LPB 5/69

APPENDIX A

EFFECTS OF TRANSMITTER OFFSET ON CRYSTAL FREQUENCIES

Vision I.F. and Test Frequency Crystals: RC1A/505

The receiver RC4/501 always employs a vision intermediate frequency of 16 Mc/s regardless of offset at the vision transmitter; the local oscillator is controlled by a crystal having an offset equal to that of the vision transmitter. Hence, the three frequencies required for alignment of the i.f. circuits are not affected by offset, and crystals for the vision i.f. (16 Mc/s) and these test frequencies (16.16, 17.5 and 19.5 Mc/s) are always provided in the Test Equipment i.f. unit.

Sound I.F. Crystal: RC1A/505

The oscillator for the sound intermediate frequency, however, is at 19.5 Mc/s only when the difference between the sound and vision carriers at the transmitter is 3.5 Mc/s, i.e., when the two carriers have no offset or have equal offsets. When the two carriers have unequal offsets, the sound i.f. oscillator must be controlled by a crystal of frequency given by the expression

$$\text{Offset crystal frequency} = 16 \text{ Mc/s} \pm \frac{\text{vision-sound spacing}}{\text{spacing}} \quad \dots (1)$$

Examples are given in the table below.

Spacing Between Sound and Vision Carriers (Mc/s)	Frequency of Crystal Required for Sound I.F. Amplifier (Mc/s)
3.5	19.5
3.48675	19.48675
3.51325	19.51325

It is unlikely that at transmitting stations more than two different sound i.f. crystals will be required and provision is made for switching two such crystals in the test equipment i.f. unit in addition to the standard 19.5-Mc/s crystal. When more crystals are required, however, as in Test Equipments carried by mobile maintenance teams,

separate crystals are needed and these may be substituted when required for the crystals fitted on the i.f. unit. In such equipment the labels showing the sound i.f. crystal frequencies would not be supplied, and the frequency marked on the envelope of the crystal unit would be the engineer's guide. Alternatively, a complete extra i.f. unit may be used, fitted with appropriate crystals and labels.

Local Oscillator Crystal: RC4/501 and RC1A/505

For offset of the vision carrier, the local oscillator in the r.f. unit of the receiver and that in the r.f. unit of the Test Equipment both require to be offset by the same amount as the vision carrier of the transmitter. Thus the frequency required is given by

$$\text{Offset crystal frequency} = 16 \text{ Mc/s} - \left\{ \begin{array}{l} \text{offset carrier} \\ \text{frequency of} \\ \text{vision transmitter} \end{array} \right\} \quad \dots (2)$$

R.F. Test Frequency Crystal: RC1A/505

The r.f. test frequency does not need to be changed for different offsets.

Example

Requirements for a Rebroadcast Receiver at Fort William, Receiving Rosemarkie on Channel 2

Rosemarkie has a vision offset of -6.75 kc/s and a sound offset of -20 kc/s.

The local oscillator frequency in both receiver and Test Equipment would be 67,750 kc/s for zero offset in Channel 2. Thus the offset crystal frequency required is $67,750 - 6.75 = 67,743.25$ kc/s.

The spacing between sound and vision carriers is 3,513.25 kc/s and from equation (1) the offset sound crystal should have a frequency given by $16,000 + 3,513.25 = 19,513.25$ kc/s. It should be fitted in the *negative* offset position.

If the Test Equipment should also be required to test a quality check receiver at Fort William, a second r.f. unit would be needed for Channel 5, zero offset; the local oscillator crystal frequency would be 82,750 kc/s. No extra sound i.f. crystal would be needed, as there is no offset on either vision or sound at Fort William.

Instruction RV.2

Appendix A

Page reissued August 1966

Notes on Ordering Crystals

The frequency tolerance on the crystals used in the Test Equipment and in the receiver is narrower than standard, a result which is obtained without prohibitive cost by relaxing the requirements of the temperature range over which the tolerance is to be met. It is important, therefore, that crystals should be ordered in the following manner:

Crystals for the RC4/501 Receiver and for the RC1A/505 Test Equipment R.F. Unit

Crystal, S.T. & C. Type C576, frequency — kc/s.
Specification C576

STC holder Type 4046 (Style D).

Frequency range, 15—100 Mc/s.

Frequency tolerance, ± 0.001 per cent at 24 degrees C.

Temperature range, +20 to +50 degrees C.
Frequency variation over temperature range (with respect to 24 degrees C), ± 0.001 per cent.

Circuit, series resonant.

Drive level, 2 mW maximum.

Crystals for the Test Equipment I.F. Unit

Quartz crystal units, Brookes Crystals Ltd.,
Type G5, B7G base.

Accuracy of adjustment to nominal frequency at 25 degrees C: ± 0.003 per cent.

Maximum frequency change due to variation of temperature between 20 and 50 degrees C: ± 0.002 per cent.

Frequency: — kc/s.

COMPONENT TABLE: FIG. 1

PAGE 1

Comp.	Loc.	Type	Tolerance per cent	Comp.	Loc.	Type	Tolerance per cent
C1	C7	T.C.C. CSM20N	5	L4	K4	DD 8271 Det. 4	
C2	C6	Erie K1200/831	+40 -20	L5	M7	DD 8271 Det. 5	
C3	C7	Erie K1200/831	+40 -20	L6	K4	DD 8271 Det. 5	
C4	C9	Erie K1200/323	20	L7	W6	DD 8271 Det. 7	
C5	D4	T.C.C. SCT1	0.5 pF	L8	L7	DD 8271 Det. 8	
C6	D6	Erie K1200/831	+40 -20	L9	T2	DD 8271 Det. 9	
C7	D2	Erie K1200/831	+40 -20	L10	C7	DD 8271 Det. 10	
C8	E5	Wingrove Rogers S50/01/1		L11	T7	DD 8271 Det. 11	
C9	E9	Erie K1200/831	+40 -20	L12	O4	DD 8271 Det. 13	
C10	F8	T.C.C. SCT1	0.5 pF	L13	R1	DD 8271 Det. 8	
C11	F2	Erie K1200/831	+40 -20				
C12	G6	Erie K1200/831	+40 -20				
C13	F8	Erie N750AD	10	R1	C9	Erie 9	10
C14	G3	Erie K1200/831	+40 -20	R2	C4	Erie 109	2
C15	H6	Erie K1200/831	+40 -20	R3	D4	Erie 9	10
C16	H10	Hunt BM14KV	20	R4	D8	Erie 9	10
C17	H5	Erie Hi-K/K	20	R5	G4	Erie 109	2
C18	H3	Erie K1200/831	+40 -20	R6	G4	Erie 109	2
C19	K5	Erie N030AD	0.5 pF	R7	G6	Erie 16	10
C20	J3	Erie K1200/831	+40 -20	R8	G8	Erie 16	10
C21	K6	Erie K1200/831	+40 -20	R9	G9	Erie 16	10
C22	K3	Erie K1200/831	+40 -20	R10	F2	Erie 9	10
C23	M5	Erie N030AD	0.5 pF	R11	G10	Erie 16	10
C24	M9	Hunt B500K	20	R12	G3	Erie 16	10
C25	N7	Erie N030AD	0.5 pF	R13	H6	Erie 16	10
C26	O6	Erie 811		R14	H2	Erie 9	10
C27	O3	Erie 811		R15	J8	Erie 16	10
C28	P6	Erie 811		R16	J9	Erie 16	10
C29	P4	T.C.C. CSM20N	5	R17	J5	Erie 16	10
C30	S9	Erie K1200/831	+40 -20	R18	J4	Erie 16	10
C31	S5	T.C.C. SCT3	10	R19	L3	Dublier BTB	10
C32	S6	Oxley A7/24		R20	L9	Erie 16	10
C33	S2	Erie K1200/362	20	R21	K2	Erie 9	10
C34	U7	T.C.C. N330AD	10	R22	N7	Erie 16	10
C35	T4	Erie N030AD	0.5 pF	R23	N6	Erie 16	10
C36	U6	Erie K1200/831	+40 -20	R24	N4	Erie 109	2
C37	V4	Erie K1200/831	+40 -20	R25	N9	Erie 16	10
C38	W5	Erie N750AD	5	R26	N9	Erie 16	10
C39	X4	Erie N030AD	0.5 pF	R27	P3	Erie 8	10
C40	X6	T.C.C. SCT1	10	R28	Q4	Erie 109	2
C42	Y7	Wingrove & Rogers		R29	Q5	Erie 109	2
C43	V9	Erie K1200/362	20	R30	Q4	Erie 109	2
C44	H7	Erie K1200/831	+40 -20	R31	R2	Erie 9	10
				R32	T8	Erie 16	10
				R33	U8	Erie 109	2
L1	C4	DD 8271 Det. 1		R34	V3	Dublier BTB	10
L2	B8	DD 8271 Det. 2		R35	V4	Erie 9	10
L3	G4	DD 8271 Det. 3		R36	W5	Erie 9	10

COMPONENT TABLE: FIG. 1

PAGE 2

Comp.	Loc.	Type	Tolerance per cent	Comp.	Loc.	Type	Tolerance per cent
R37	W6	Erie 9	10	R41	A7	Erie 109	1
R38	J3	Erie 9	10	R42	A6	Erie 109	1
R39	A8	Erie 109	1	R43	A8	Erie 109	1
R40	A7	Erie 109	1	R44	A6	Erie 109	1

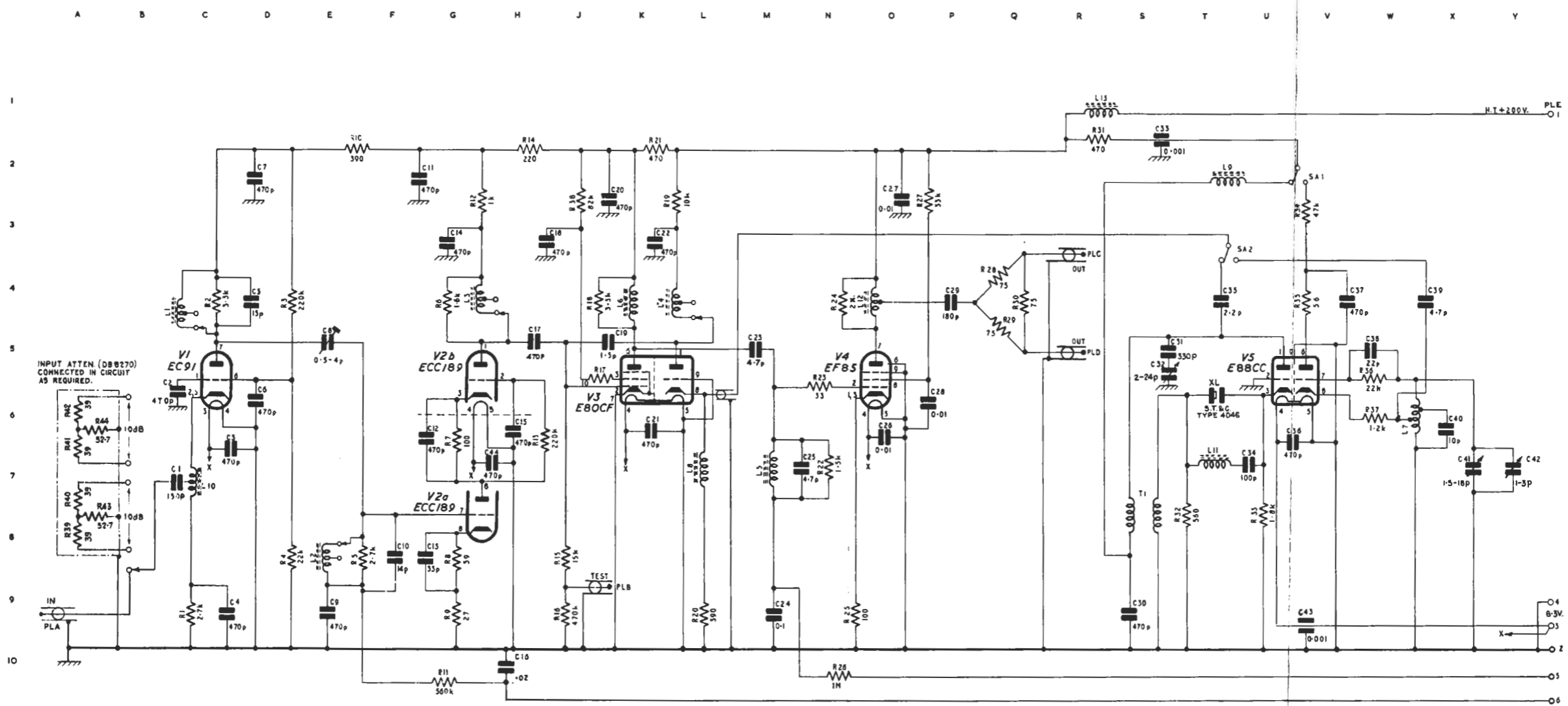

INPUT ATTEN. (DB8270)
CONNECTED IN CIRCUIT
AS REQUIRED.

VALVE BASES

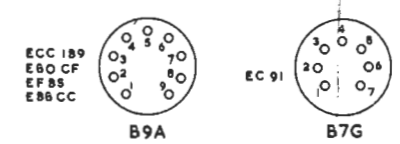

R.F. UNIT RCIA/503 : CIRCUIT

This drawing is the property of the British Broadcasting Corporation and may not be reproduced or disclosed to a third party in any form without the written permission of the Corporation.

COMPONENT TABLE: FIG. 2

PAGE I

Comp.	Loc.	Type	Tolerance per cent	Comp.	Loc.	Type	Tolerance per cent
C1	A5	T.C.C. CSM120U	2	C49	B5	Erie N750AD	
C2	A7	Oxley A7/12-5D					
C3	C6	T.C.C. CSM120U	2				
C4	E6	T.C.C. CTU425	2				
C5	F6	Erie N030AD	5	L1	A6	DC 7911 Det. 9 DD 7910 Det. 8 DD 7910 Det. 9	
C6	F6	Oxley A7/30D					
C7	G6	Oxley					
C8	H7	T.C.C. CSM20N	5	L2	A6	DC 7911 Det. 5	
C9	H6	Erie K7004/811	P	L3	C6	DC 7911 Det. 11	
C10	J4	Erie K7004/811	P	L4	E4	DC 7911 Det. 1	
C11	J6	Erie K7004/811	P	L5	E6	DA 829I	
C12	J3	Erie HIK/K	20	L6	H7	DC 7911 Det. 10	
C13	K2	Erie K7004/811	P	L7	H2	DC 7911 Det. 2	
C14	K6	Oxley A7/18D		L8	L2	DC 7911 Det. 3	
C15	K8	Erie K7004/811	P	L9	N2	DC 7911 Det. 4	
C16	L5	Erie K7004/811	P	L10	P2	DC 7911 Det. 2	
C17	L6	Erie K7004/811	P	L11	S2	DC 7911 Det. 3	
C18	M3	Erie HIK/K	20	L12	U2	DC 7911 Det. 12	
C19	M2	Erie K7004/811	P	L13	Z4	DC 7911 Det. 6	
C20	M6	Oxley A7/18D		L14	AA7	DC 7911 Det. 13	
C21	N8	Erie K7004/811	P	L15	B5		
C22	N5	Erie K7004/811	P				
C23	O6	Erie K7004/811	P	R1	B6	Erie 109	2
C24	O3	Erie HIK/K	20	R2	B6	Erie 109	2
C25	O2	Erie K7004/811	P	R3	C6	Erie 109	2
C26	P6	Oxley A7/18D		R4	D4	Erie 9	10
C27	P8	Erie K7004/811	P	R5	D4	Erie 109	2
C28	P4	Erie K7004/811	P	R6	D6	Erie 109	2
C29	Q6	Erie K7004/811	P	R7	G6	Erie 109	2
C30	Q3	Erie HIK/K	20	R8	H6	Erie 109	2
C31	R2	Erie K7004/811	P	R9	H4	Erie 8	10
C32	R6	Oxley A7/18D		R10	J8	Erie 9	10
C33	R8	Erie K7004/811	P	R11	J2	Erie 8	10
C34	S5	Erie K7004/811	P	R12	K6	Erie 109	2
C35	S6	Erie K7004/811	P	R13	K1	Erie 109	10
C36	T3	Erie HIK/K	20	R14	L6	Erie 9	10
C37	T2	Erie K7004/811	P	R15	L9	Erie 9	10
C38	T6	Oxley A7/18D		R16	L2	Erie 8	10
C39	T8	Erie K7004/811	P	R17	M6	Erie 109	2
C40	U5	Erie K7004/811	P	R18	N2	Erie 9	10
C41	U6	Erie K7004/811	P	R19	N6	Erie 9	10
C42	V6	Erie K7004/811	P	R20	N9	Erie 9	10
C43	V4	Oxley A7/6-5D		R21	O2	Erie 8	10
C44	V3	Erie HIK/K	20	R22	O6	Erie 109	2
C45	V2	Erie K7004/811	P	R23	P1	Erie 8	10
C47	AA7	Erie N750K	10	R24	P6	Erie 9	10
C48	B8	Erie N750AD		R25	Q9	Erie 9	10

COMPONENT TABLE: FIG. 2

PAGE 2

Comp.	Loc.	Type	Tolerance per cent	Comp.	Loc.	Type	Tolerance per cent
R26	Q2	Erie 8	10	R37	Z6	Erie 109	2
R27	Q6	Erie 109	2	R38	Z4	Erie 109	2
R28	R1	Erie 8	10	R39	AA4	Erie 16	10
R29	R6	Erie 9	10	R40	A7	Erie 16	10
R30	S9	Erie 9	10	R41	AB4	Erie 16	10
R31	S2	Erie 8	10	R42	D6	Erie 109	2
R32	T6	Erie 109	2	R43	V4	Erie 109	2
				RV1	D5	Plessey MH2	
R33	T4	Erie 9	10				
R34	T1	Erie 9	10				
R35	T6	Erie 109	2	TI	X4	{ DC 7911 Det. 7 DD 7910 Det. 5	
R36	V2	Erie 8	10				

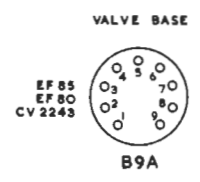
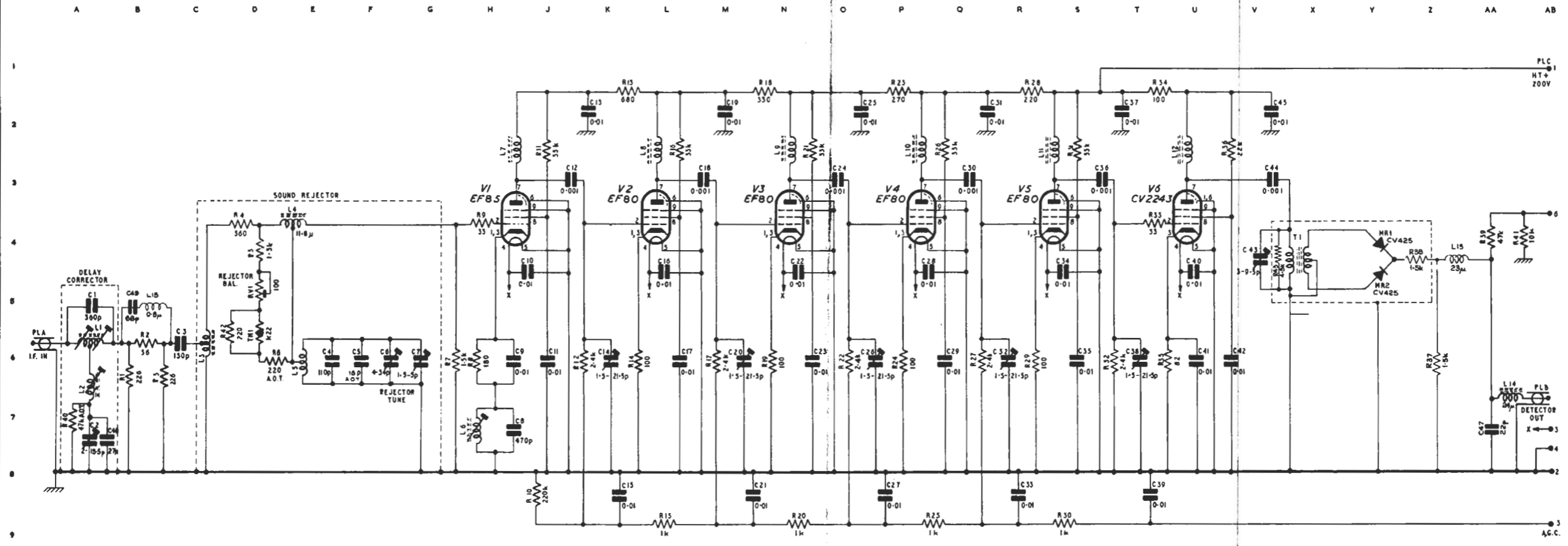

VISION I.F. AMPLIFIER AND DETECTOR RCIA/502: CIRCUIT

This drawing is the property of the British Broadcasting Corporation and may not be reproduced or disclosed to a third party in any form without the written permission of the Corporation.

COMPONENT TABLE: FIG. 3

Comp.	Loc.	Type	Tolerance per cent	Comp.	Loc.	Type	Tolerance per cent
C10	B4	T.C.C. CSM20N		R49	F4	Erie 9	10
C11	A7	Hunt B503K		R50	E6	Painton P301A	5
C12	C7	Hunt B514K		R51	F6	Painton P301A	5
C13	C9	Plessey CE17182/12		R52	G6	Erie 9	10
C14	D6	Plessey CE811/1		R53	G6	Erie 108	2
C15	D7	Plessey CE874/1		R54	G6	Erie 100	2
C16	E9	Hunt B553K		R55	G1	Erie 9	10
C17	F9	Plessey CE17143/14		R56	J9	Erie 9	10
C18	E5	T.C.C. CSM20N		R57	H4	Erie 100	2
C19	G5	Hunt B810		R58	H1	Erie 108	2
C20	H6	Plessey CE811/1		R59	J7	Erie 9	10
C21	H7	T.C.C. CSM20N		R60	J4	Erie 109	2
C22	J2	Hunt B810		R61	K9	Erie 9	10
C23	K9	Plessey CE1214/1		R62	K7	Erie 9	10
C24	L6	Plessey CE811/1		R63	K6	Erie 9	10
C25	L4	Hunt B818		R64	K1	Erie 9	10
C26	M6	Hunt B810		R65	L7	Erie 9	10
C27	M4	Hunt B503K		R66	L4	Erie 9	10
C28	M5	Plessey CE1206/13		R67	L2	Erie 9	10
C29	U4	Hunt B503K		R68	M4	Erie 109	2
C31	C2	Hunt B810		R69	P2	Erie 16	10
C32	K7	Hunt B810		R70	N5	Erie 109	2
C33	P4	Plessey CE1214/1		R71	N4	Erie 109	2
C34	E8	Erie N030AD		R72	O5	Erie 9	10
C35	D12	Erie N3300AD		R73	O4	Erie 9	10
C36	E12	Erie N3300AD		R74	O3	Erie 9	10
				R76	P4	Erie 109	2
				R77	Q4	Erie 9	10
L2	E8	DA 8203 Det. 2		R78	Q3	Erie 109	2
L3	D12	DA 8203 Det. 3		R79	Q4	Erie 9	10
L4	E12	DA 8203 Det. 3		R80	S4	Erie 109	2
				R81	E3	Erie 9	10
R33	A6	Erie 9	10	R82	S2	Erie 109	2
R34	B8	Erie 9	10	R83	S4	Erie 109	2
R35	B9	Erie 9	10	R84	T4	Erie 109	2
R36	B9	Erie 9	10	R85	T4	Erie 9	10
R37	B4	Erie 9	10	R86	A4	Erie 9	10
R38	C6	Erie 9	10	R87	B3	Erie 9	10
R39	C1	Painton P301A	5	R91	G3	Erie 9	10
R40	C9	Erie 9	10	R92	E7	Erie 9	10
R41	D9	Erie 9	10	R94	D8	Erie 109	2
R42	D9	Erie 109	2	R95	D11	Erie 109	2
R43	D4	Erie 100	2	R96	E11	Erie 109	2
R44	D4	Erie 109	2	R98	C98	Painton P301A	5
R45	D1	Erie 9	10				
R46	D11	Erie 9	10	RV3	H3	Colvern CLR 1132/155	10
R47	D11	Erie 9	10	RV4	O4	Colvern CLR 1132/155	10
R48	E9	Erie 109	2	RV5	S4	Morganite LH/WN	20

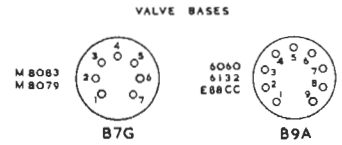
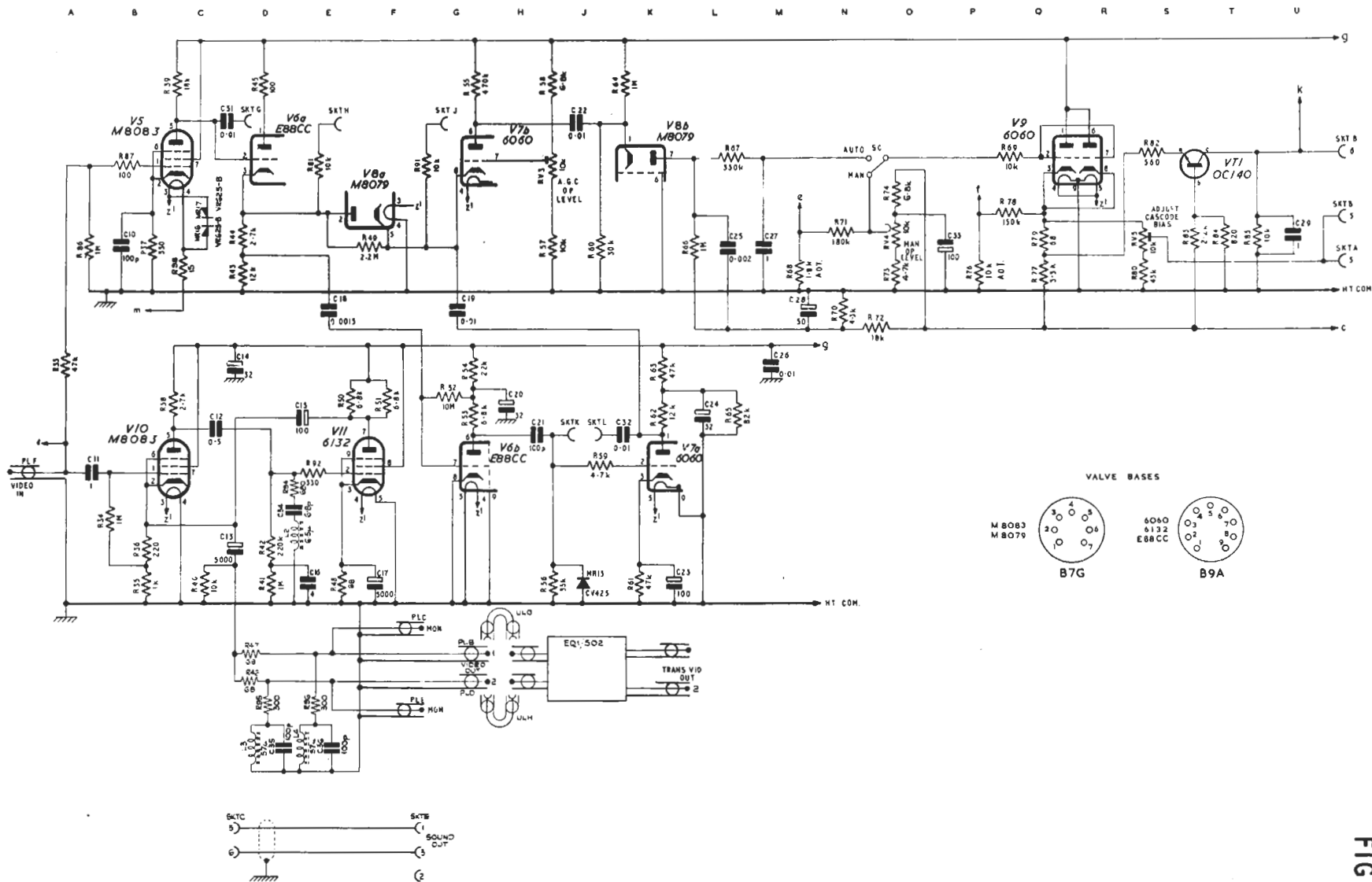

VIDEO AMPLIFIER AND AGC UNIT RC4/501: CIRCUIT

FIG 3

COMPONENT TABLE: FIG. 4

Comp.	Loc.	Type	Tolerance per cent	Comp.	Loc.	Type	Tolerance per cent
C1	B5	T.C.C. SCT2	5	R2	B4	Erie 109	2
C2	C5	T.C.C. SCT2		R3	C6	Erie 16	10
C3	D3	Erie K7004/811	P	R4	D4	Erie 9	10
C4	D2	Erie K7004/811	P	R5	E2	Erie 16	10
C5	D5	Erie K7004/811	P	R6	E3	Erie 16	10
C6	J6	Hunt B500K		R7	B5	Erie 9	10
C7	E2	Erie N030AD	5	R8	E4	Erie 9	10
C8	F5	Erie K7004/811	P	R9	E7	Erie 16	10
C9	F4	Erie K7004/811	P	R10	E1	Erie 8	10
C10	F2	Erie N030AD	5	R11	G7	Erie 16	10
C11	G5	Erie K7004/811	P	R12	G5	Erie 8	10
C12	G2	Erie K7004/811	P	R13	G4	Erie 9	10
C13	G2	Erie N030AD	5	R14	H1	Erie 8	10
C14	H5	Erie K7004/811	P	R15	J7	Erie 16	10
C15	H4	Erie K7004/811	P	R16	K7	Erie 16	10
C16	J2	Erie N030AD	5	R17	K5	Erie 9	10
C17	H6	Erie K7004/811	P	R18	K4	Erie 9	10
C18	J2	Erie K7004/811	P	R19	K1	Erie 8	10
C19	K2	Erie N030AD	5	R20	L2	Erie 16	10
C20	L5	Erie K7004/811	P	R21	M5	Erie 16	10
C21	L4	Erie K7004/811	P	R22	N5	Erie 9	10
C22	L2	Erie N030AD	5	R24	O5	Erie 16	10
C23	M3	Erie N750K		R25	P4	Erie 16	10
C24	N5	Erie N750K		R26	Q5	Erie 16	10
C25	O3	Hunt B501K		R27	Q5	Erie 16	10
C26	P5	Erie K7004/811	P	R29	R4	Erie 16	10
C27	Q5	Erie K7004/811	P	R30	R4	Erie 16	10
C28	R3	Hunt B501K		R31	R6	Erie 16	10
C29	R2	T.C.C. CP33N/PVC		R32	R5	Erie 16	10
C30	S4	Erie K7004/811	P	R33	R4	Erie 16	10
C31	S3	Hunt B513K		R34	S2	Painton P301A	5
C32	T3	Erie Hi-k/K					
C33	R4	Erie K7004/811	P				
C34	G6	Hunt B500K		RV1	O4	Plessey E	
L1	C3	DB 8034 Det. 1		T1	F2	DB 8034 Det. 2	
L2	C4	DB 8034 Det. 1		T2	H2	DB 8034 Det. 3	
				T3	L2	DB 8034 Det. 4	
				T4	T3	AL/19SA	
RI	B3	Erie 109	2				

This drawing is the property of the British Broadcasting Corporation and may not be reproduced or disclosed to a third party in any form without the written permission of the Corporation.

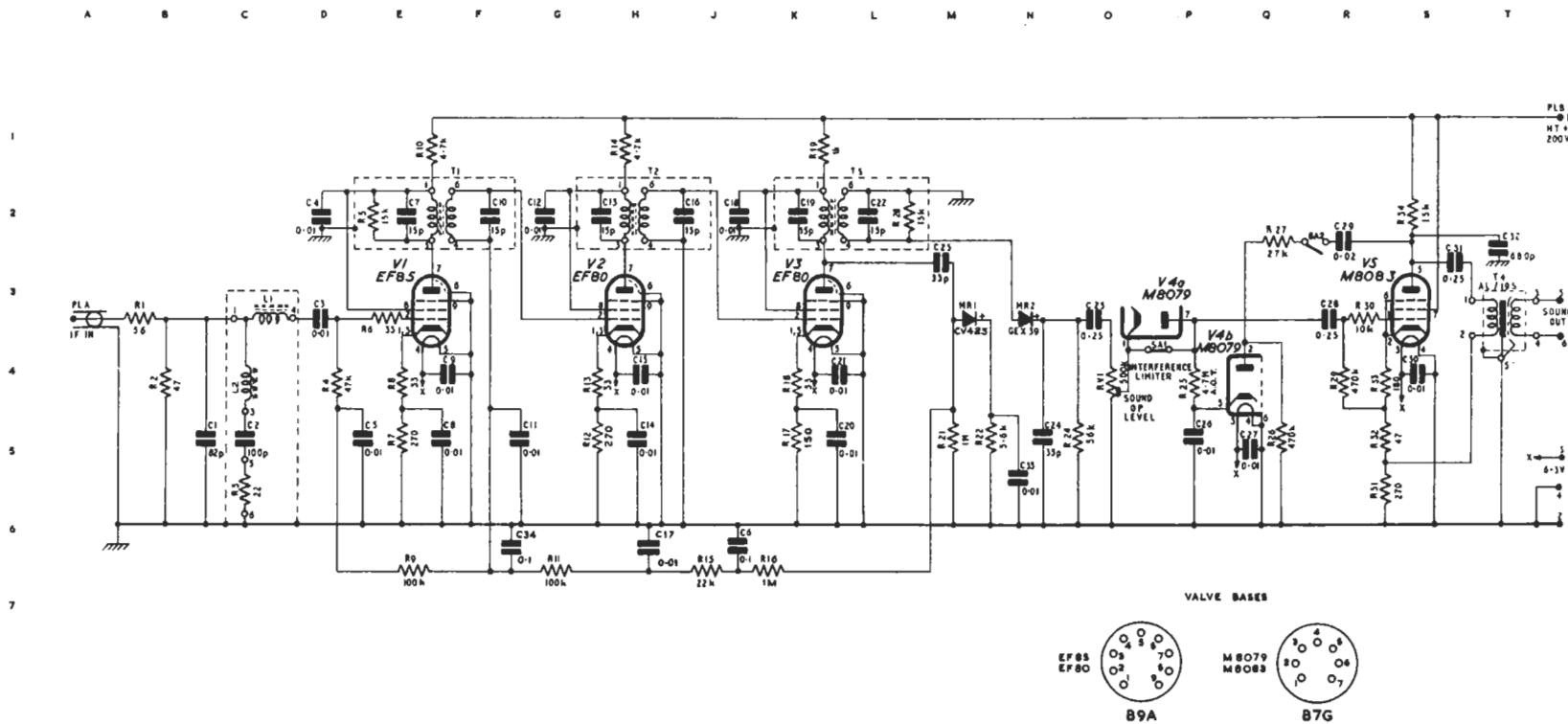

SOUND I.F. AMPLIFIER AND DETECTOR RCIA/501: CIRCUIT

COMPONENT TABLE: FIG. 5

Comp.	Loc.	Type	Tolerance per cent	Comp.	Loc.	Type	Tolerance per cent
C1	J2	Plessey CE874/1		R17	Q5	Erie 9	10
C2	K2	Plessey CE 874/1		R18	Q2	Erie 16	10
C3	L2	Plessey CE 874/1		R19	Q8	Erie 9	10
C4	P8	Plessey CE 874/1		R20	R7	Erie 9	10
C5	P7	Hunt B513K		R21	J4	Painton MVIA	5
C6	R7	Plessey CE 874/1		R22	K4	Painton MVIA	5
C7	H4	Plessey CE 17027/1		R23	F6	Painton MVIA	5
C8	J4	Plessey CE 17027/1		R24	G6	Erie 109	10
C9	G6	T.C.C. CP37S/PVC		R25	Y6	Erie 9	10
C30	D16	Erie K3500/831		R26	X3	Painton MVIA	5
				R27	Y3	Painton MVIA	5
				R28	Y3	Painton MVIA	5
LI	C17	DA 8203 Det. I		R29	Z3	Painton MVIA	5
				R30	AC1	Erie 109	2
R1	K2	Berco KO. VGH	10	R31	AB3	Erie 108	2
R2	F3	Erie 9	10	R32	AC6	Erie 9	10
R3	M6	Painton P302A	5	R88	Y7	Erie 109	2
R5	M2	Erie 9	10	R89	AC3	Erie 109	2
R6	N3	Erie 16	10	R90	Z7	Erie 109	2
R7	N5	Erie 9	10	R93	F1	Painton P301A	5
R8	N2	Erie 9	10	R97	E1	Erie 9	10
R9	O2	Erie 9	10	R99	S8	Erie 9	10
R10	O5	Erie 9	10				
R11	O3	Erie 16	10	RV1	Q7	Colvern CLR/1132/155	10
R12	P3	Erie 16	10	RV2	Y6	Morganite LH/WN	20
R13	P2	Erie 9	10				
R14	Q2	Erie 9	10				
R15	Q8	Erie 9	10				
R16	Q7	Erie 9	10	T1	D2	M.261	

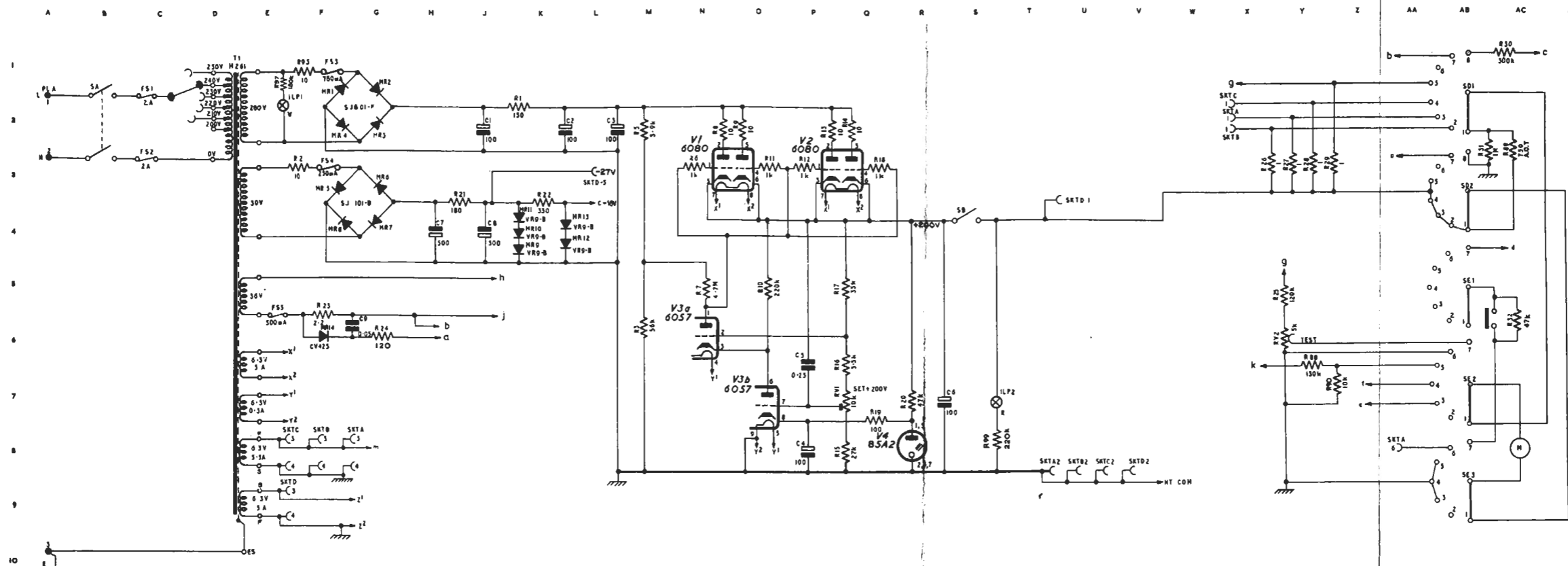

POWER SUPPLY RC4/501: CIRCUIT

- S D ENGRAVING
- 1 H.T. + 300V
 - 2 H. F.
 - 3 I. F.
 - 4 SOUND
 - 5 VID. & A.G.C.
 - 6 HEAD 0.5A
 - 7 -VE 50V
- H.T. FEEDS 150 mA

- SE ENGRAVING
- 1 SD
 - 2 MAN
 - 3 I.F.
 - 4 CAS
 - 5 CORR.
 - 7 TEST
- BIAS 15V

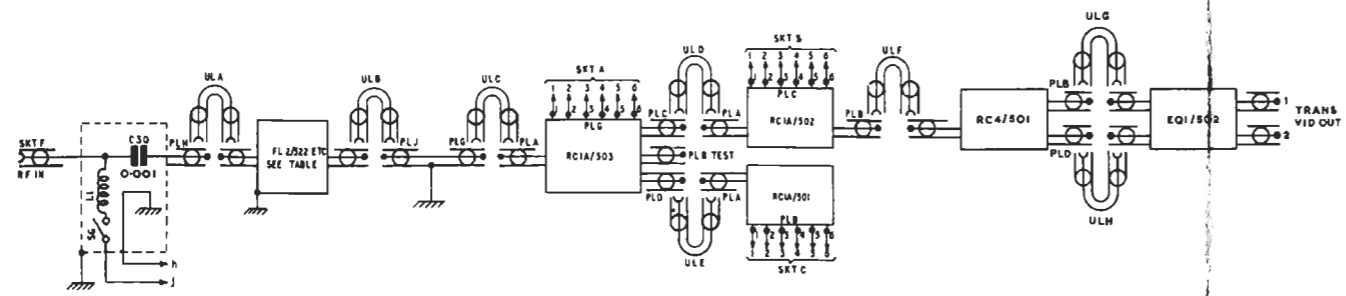
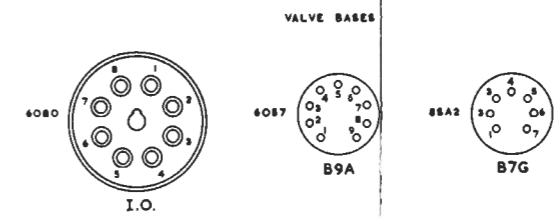

UNIT CONNECTIONS RC4/501: BLOCK DIAGRAM

FILTER CODE	CHANNEL NUMBER
FL2/522	1
FL2/523	2
FL2/524	3
FL2/525	4
FL2/526	5

This drawing is the property of the British Broadcasting Corporation and may not be reproduced or disclosed to a third party in any form without the written permission of the Corporation.

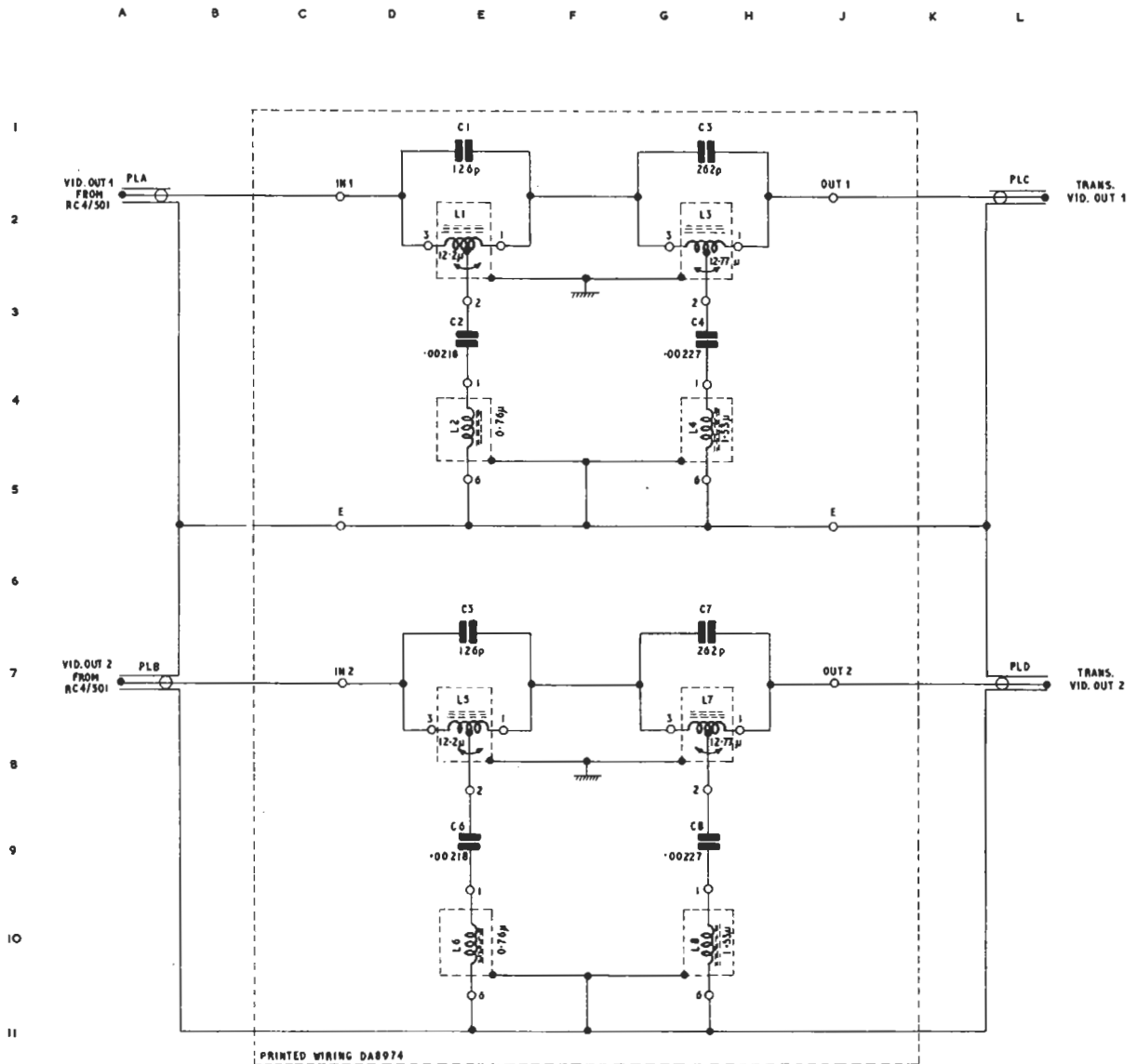

NOTE:- ALL CAPACITORS ARE GEC 125-V TYPE
INDUCTORS TO DRAWING DA 8976

DELAY EQUALISER EQ1/502 : CIRCUIT

This drawing is the property of the British Broadcasting Corporation and may not be reproduced or disclosed to a third party in any form without the written permission of the Corporation.

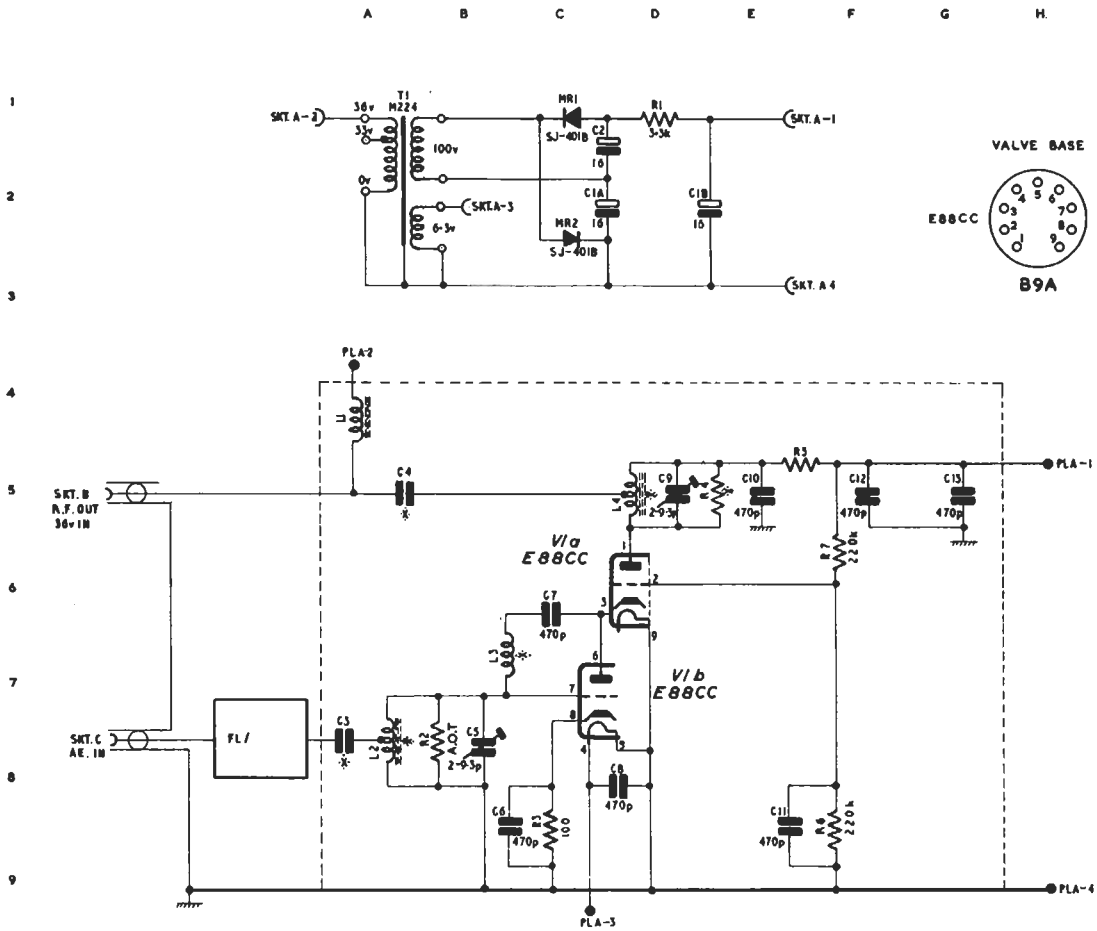

This drawing is the property of the British Broadcasting Corporation and may not be reproduced or disclosed to a third party in any form without the written permission of the Corporation.

HEAD AMPLIFIER RC1A/504: CIRCUIT

NOTE
DETAILS OF COMPONENTS MARKED *
DEPEND ON CHANNEL FREQUENCY

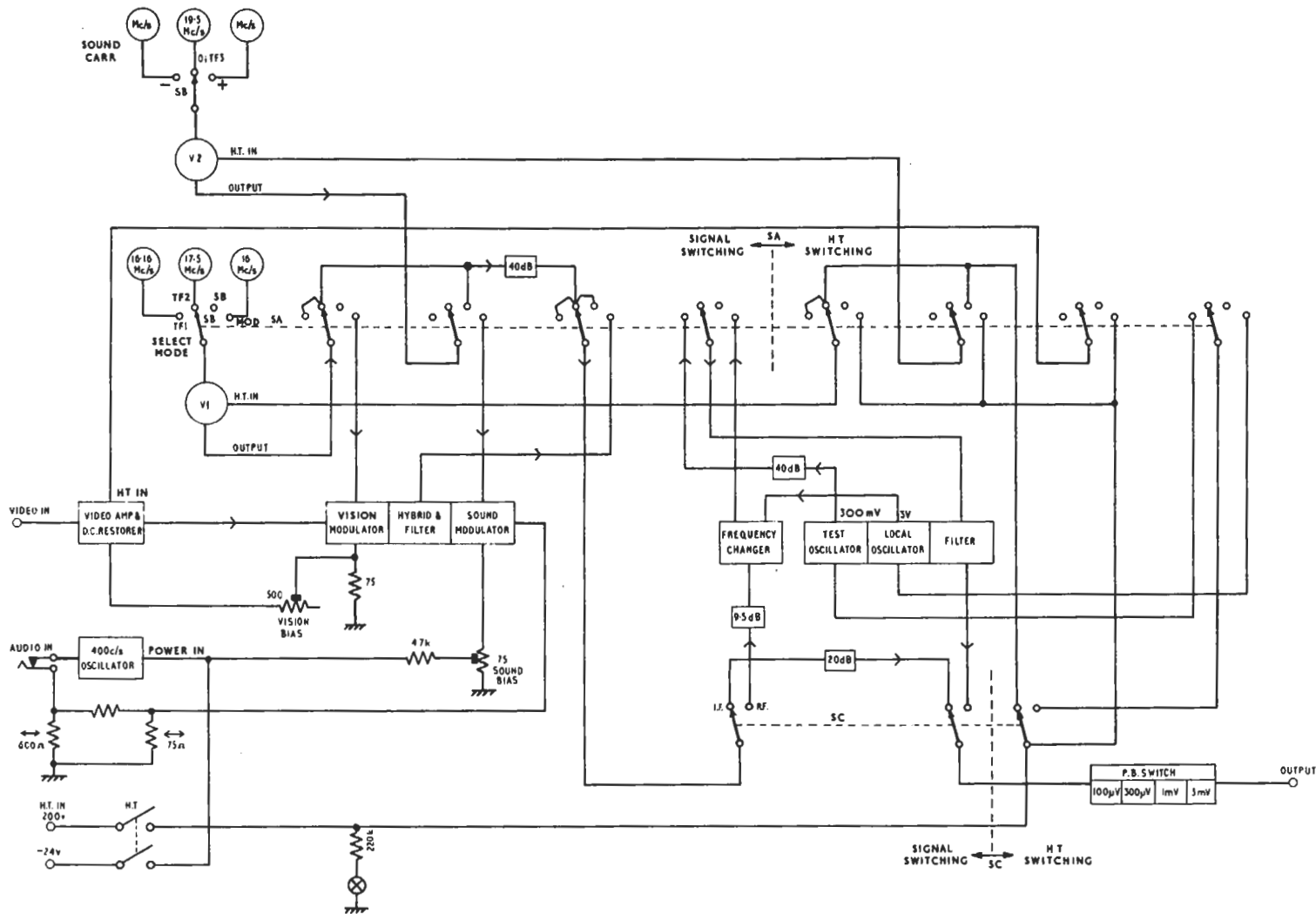

TEST EQUIPMENT RCIA/504: BLOCK DIAGRAM