

**AUXILIARY WAVEFORM AND PULSE TIMING GENERATOR GE2/561
PULSE TIMING GENERATOR GE2/562**

Introduction

The GE2/561, with its sub-unit GE2/562, normally forms part of the 625-line Chrominance/Luminance Pulse and Bar Generator GE2/559. It provides:

- (a) a feed of sync pulses and 5 feeds of trigger pulses, each having individual delays with respect to the sync pulses
- (b) a 50-Hz waveform (consisting of a train of 50- μ s line bars) which is switched off and on at 10 ms intervals
- (c) a line-frequency sawtooth waveform

Selection of the required waveform is by means of a three-position front-panel switch.

There are two modes of operation, corresponding to an internally-generated or external supply of syncs. Selection is by means of a front-panel switch. In the external mode a supply of mixed-blanking is required also.

The GE2/561 consists of two printed boards mounted in a CH1/26A chassis, the smaller board accommodating the GE2/562 sub-unit. There is a single index peg in position 2. An external power supply is required.

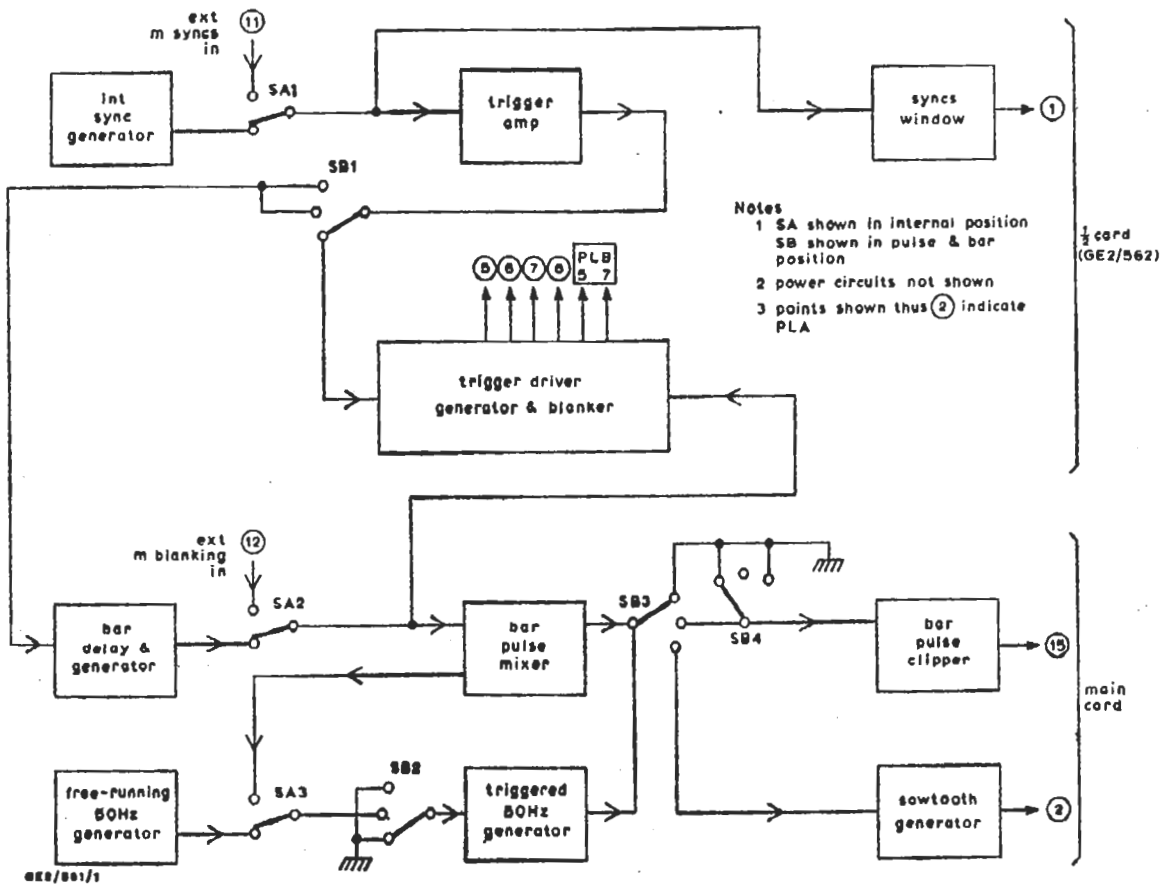

Fig. 1. Block Diagram of the GE2/561 (Including GE2/562)

General Specification

Inputs (external mode)

Mixed Syncs 2 V p-p
Mixed Blanking 2 V p-p

Outputs

Sync Pulses 0.3 V p-p
from GE2/562
Trigger Pulses 3 V
from GE2/562
50-Hz modulated 2 V p-p
waveform
Sawtooth waveform 0.7 V p-p

Duration of Trigger Pulses 2 μ s

Trigger Pulse Delays See Fig. 3

Power Supplies 40 mA at +12 V
100 mA at -12 V

Circuit Description

A block diagram for the GE2/561 and its sub-unit GE2/562 is given in Fig. 10. Circuit diagrams are given in Fig. 2 and Fig. 3.

Trigger Pulse Generators (GE2/562)

The five trigger pulse generators formed by TR8/TR9, TR10/TR11, TR12/TR13, TR16/TR17 and TR19/TR20 are used to initiate the generation of the component parts of the chrominance/luminance pulse-and-bar waveform by other associated units of the GE2/559. (TR14/TR15 are not used when the GE2/562 is a sub-unit of the GE2/561 in the GE2/559.)

The generators are triggered by the leading edge of syncs except for TR19/TR20 which is triggered by TR16/TR17. The positive-going pulse from each generator is differentiated and the negative-going peak passed to the output.

The sync pulses, either external or internal depending on the position of SA in the GE2/561, are differentiated by C4/R6; the leading edge is amplified by TR3 and TR6 (terminals 7 and 10 are joined in the parent unit by switch SB in its pulse and bar position).

Generation of 50 Hz waveform (switch SB in the 50-Hz bar position)

Positive trigger pulses (leading edge of syncs) from the sub-unit trigger the bar-delay generator TR1/TR2 which produces a 12- μ s positive-going pulse at TR2 collector. This is differentiated by C3/R8 and the trailing edge is inverted by TR3 to trigger TR4/TR5, the bar generator. The output from TR5 is a positive-going bar waveform with a duration of 50 μ s; i.e., it covers the active line period.

In the internal mode, TR10/TR11 forms a free-running 50-Hz generator which drives the 50-Hz square wave generator TR13/TR14. The output of this generator is mixed with the signal from

TR5 in the common collector circuit of TR7. The input to the bar clipper stage TR8/TR9 is thus a series of line bars which are switched on and off at the 50-Hz rate.

In the external mode, mixed blanking replaces the signal from TR10/TR11; the generation of the modulated waveform is otherwise as above.

Generation of Line Sawtooth Waveform (switch SB in sawtooth position)

The signal from the bar generator drives the sawtooth generator TR15/TR16/TR17/TR18, (the 50-Hz triggered generator is inoperative as its input is earthed). During the line-blanking period TR15 conducts because its input signal is negative going and D7 is cut off. TR16 conducts and C18 is discharged. During the active line period, the opposite condition exists and C18 charges. The sawtooth thus developed is inverted by TR19 and fed to the output terminal. The bootstrap connection via TR18 and C19 linearises the current into C18 and hence also the output waveform.

Maintenance

Routine maintenance is not required, but the following points should be checked occasionally.

GE2/562

The duration of the internally generated line-sync pulses should be not more than 0.5 μ s longer than the duration of the external sync pulses. Adjustment is by means of the a.o.t. capacitor C1B. The half-amplitude duration of the internal sync pulses should be 4.7 μ s \pm 0.2 μ s.

GE2/561

1. Connect an oscilloscope to the output connector, PLA 15, and apply external field-trigger pulses to the trigger input of the oscilloscope. Set switch SA on the GE2/561 to its 50-Hz position and set SB to external sync. Check that the mark/space ratio of the displayed waveform is 1.
2. Set SA to internal sync; the period of the 50-Hz waveform should be very slightly longer than in the external sync condition. This is observed by a slow movement of the oscilloscope trace from left to right. R57 is the controlling component.
3. Check that the leading edge of the line bar component is 0.5 μ s earlier on internal syncs than on external syncs.
4. Check that the amplitude of the sawtooth waveform when using internal syncs is within +0 and -0.05 dB of the amplitude obtained when using external syncs.

References

1. Designs Department Specification No. 9.95(68).
AIB 6/70

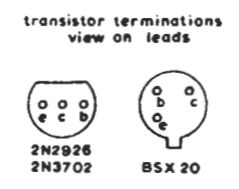
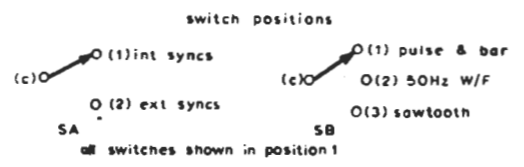
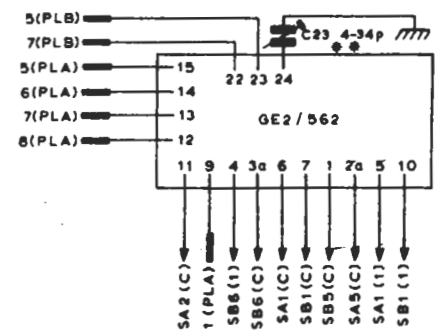
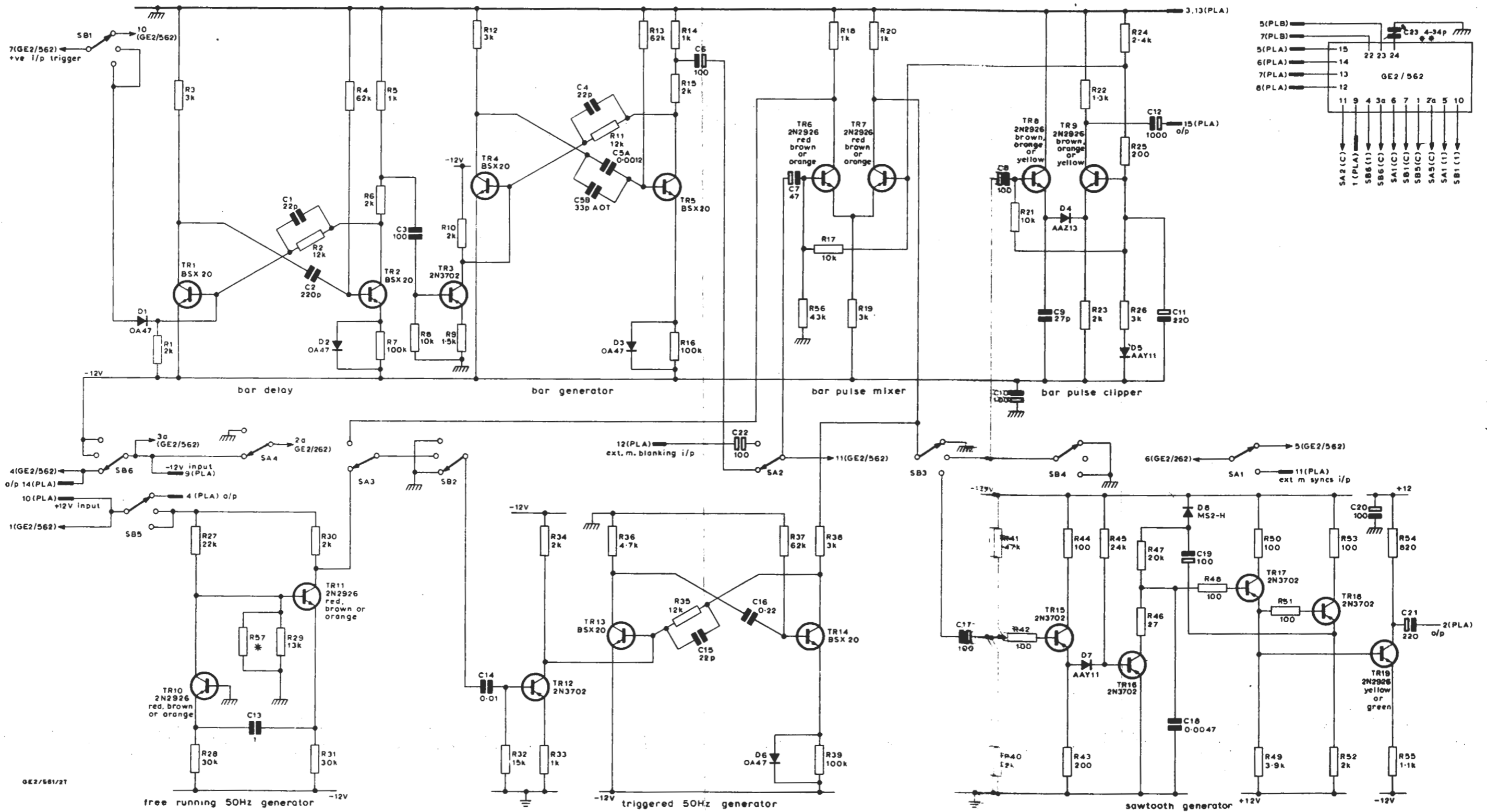

* denotes value to be determined on test
 * * fitted to GE2/561A only
Fig.2 Circuit of GE2/561 (see also Fig.3)

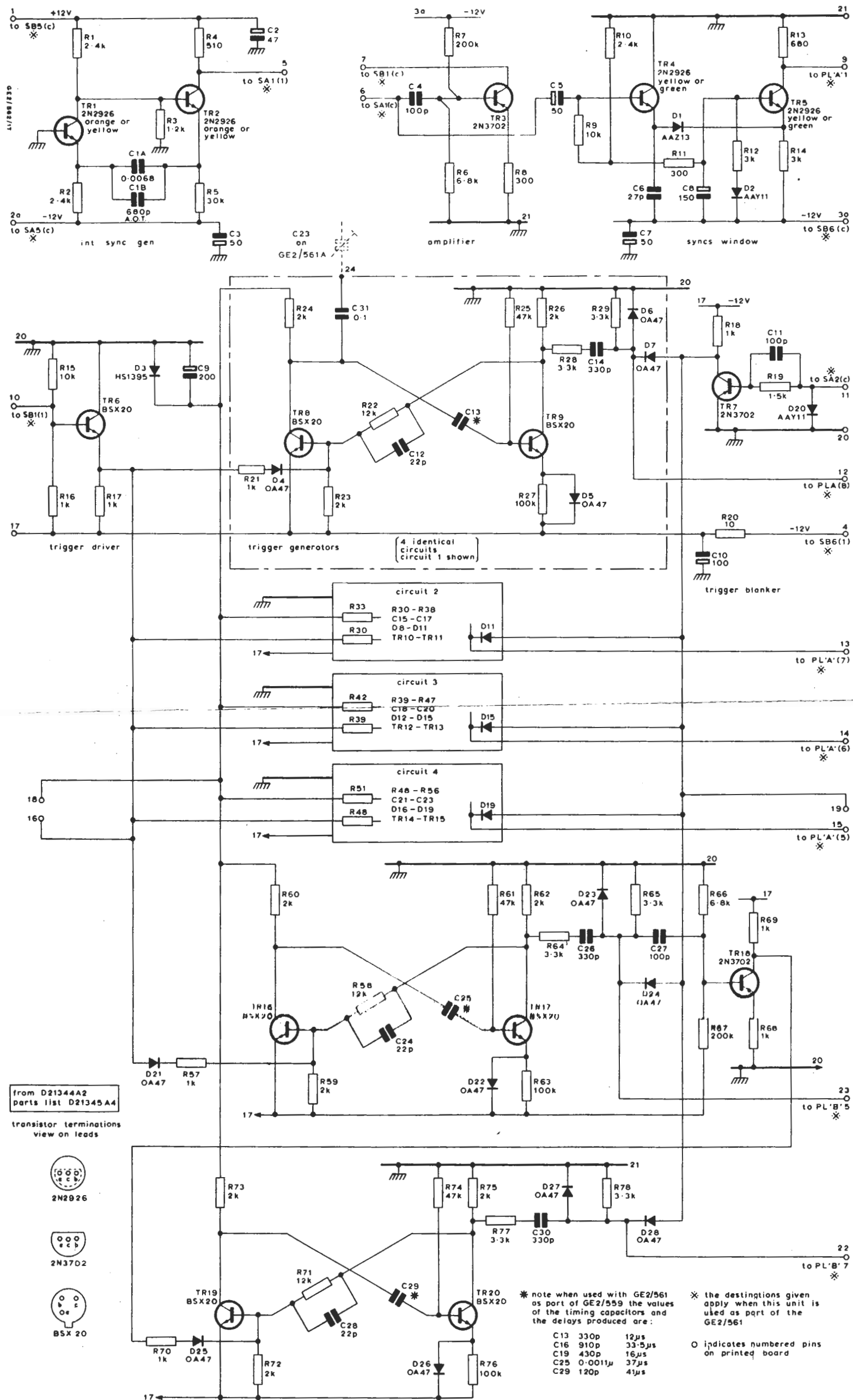

Fig. 3 Circuit of the GE2/562