

SECTION 20

O.B. EQUIPMENT OBA/9

Introduction

The OBA/9 O.B. equipment is intended to replace the OBA/8 amplifier and its associated apparatus which have been in use since shortly before the war. The main advantages of the new design are smaller size and weight, both of which have been reduced by nearly 50 per cent, and the arrangement of the equipment to form a largely self-contained assembly which can be put into use with a minimum of time and effort. The general technical performance is not greatly altered, although some slight improvements from this aspect have also been made.

All the major units are of uniform dimensions and are so designed that they can be stacked together on a special two-wheeled trolley which facilitates transport and can be operated in this position without dismantling the stack. The trolley can if necessary be lifted bodily by two persons, and has special fittings for carrying microphone-cable drums which allow the cable to be run out, connected up and re-coiled without removing the drums. The total weight of the trolley when fully equipped is about 186 lb; in addition there is a loudspeaker unit and also a spares box with miscellaneous items which together weigh about another 86 lb. The loudspeaker and the spares box have the same width and depth as the other apparatus, and can thus be carried on a second trolley together with any supplementary units, when circumstances require.

Mechanical Design Considerations

The apparatus cases are constructed of aluminium alloy, with welded seams. Their overall dimensions, including face-plate covers, are 19½ in. wide by 9 in. deep by 5¾ in. high, an exception being the power-supply unit, with a height of 7¾ in. Two lengthwise grooves are formed in the top of each case, and corresponding ridges are formed on the underside; these add to the rigidity of the construction and provide a means of locating the case in a stack and interlocking the cases when the ends of the stack are secured.

The cases fit closely within the framework of the trolley, where they are held by pressure applied to a groove of the uppermost case by captive thumbscrews working on a bar hinged to the trolley uprights; a raised strip at the base of the trolley prevents forward movement of the lowest case. By this means the apparatus assembly is rigidly locked in the trolley framework, although it may be released and removed in a few seconds.

The two wheels of the trolley have thick solid-rubber tyres and are mounted slightly above the platform so that with the trolley upright the wheels are just off the ground and the assembly stands firmly on three feet fitted to the base. Two hand-grips are provided at the front edge of the base. The trolley is of welded construction with a framework of cold-drawn mild-steel tubing and a sheet-steel base.

The overall height of the stack of apparatus excluding the trolley is 37 in. and the weight (including the batteries carried in the power supply unit) is 103 lb.

Electrical Design Considerations

The equipment has been designed so that it can be operated either from a.c. mains or from batteries. Normally the microphone amplifier in use is operated from the mains while the standby is fed from batteries, a changeover being instantaneous; no standby supply is provided for the loudspeaker amplifier (which also incorporates a trap-valve), but where no mains are available the whole equipment can be operated from batteries. The power-supply circuits are designed to operate on a.c. mains within the voltage range 200-250 volts and frequency range 45-60 c/s.

The valves and other components used have been chosen from the BBC or the Services preferred lists where a suitable type exists with a view to maintenance of supplies of spares.

The new equipment, like the one it replaces, is suitable for static use should circumstances require.

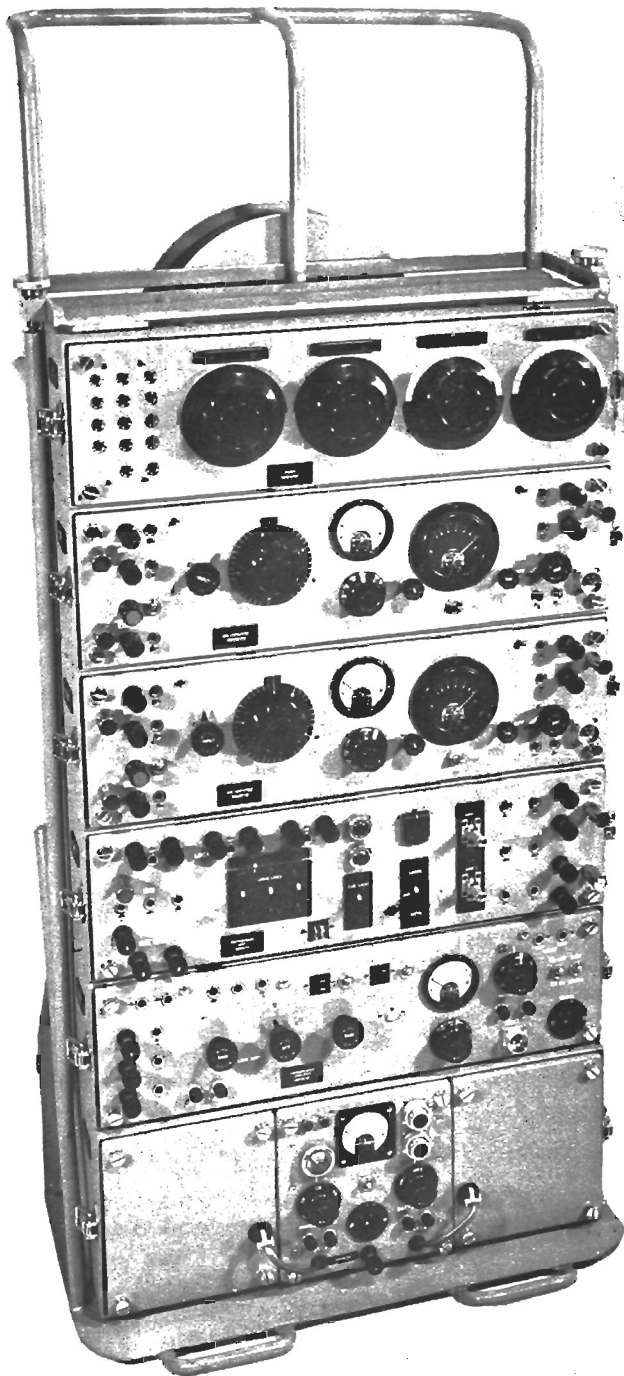

SPACE FOR
SPARE MIXER

MIXER
MX/29

AMPLIFIER
OBA/9

AMPLIFIER
OBA/9

DISTRIBUTION
UNIT DU/1

AMPLIFIER
LSM/9

SUPPLY UNIT
SUP/6

TROLLEY
TRL/1

Fig. 20.1 OBA/9 Equipment: Trolley Assembly

Summary of Equipment

Trolley Assembly

The O.B. trolley, Type TRL/1, is shown fully equipped in Fig. 20.1 The apparatus mounted is as follows:

- 1 Mixer MX/29,
- 2 Amplifiers OBA/9,
- 1 Distribution Unit DU/1,
- 1 Amplifier LSM/9,
- 1 Supply Unit SUP/6,
- 3 Cable Drums DUM/6.

Additional Standard Items

Ignoring gear common to all O.B. equipments, such as a cue radio receiver and microphone stands, the additional items provided as standard for use with the OBA/9 are:

- 1 Loudspeaker Unit LSU/11,
- 3 Communication Units CMU/9,
- 1 Communication Unit CMU/10,
- 1 Wooden Box BW/9. This carries spares and minor items including cords and power cables and the three communication units Type CMU/9.

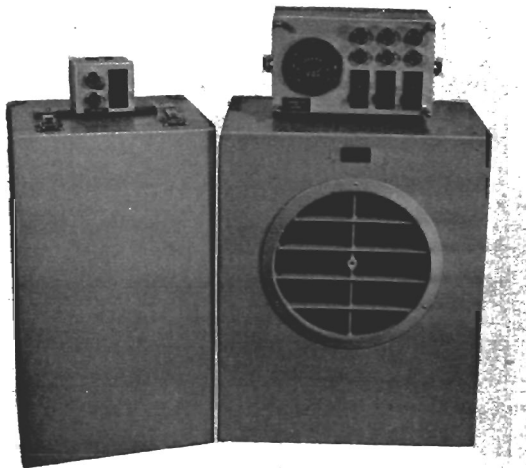

Fig. 20.2 CMU/9, CMU/10, BW/9 and LSU/11

Supplementary Items

A second mixer MX/29 can be carried on the trolley if required. To permit the consequent increase in the height of the stack of apparatus, the clamping bar has to be unhinged from the trolley uprights and reassembled to them higher up.

A variable-frequency oscillator Type PTS/16 may also be carried. This instrument is of a conveniently miniaturised design suitable for O.B. purposes, and is capable of taking its power supplies from the SUP/6 unit. It can if necessary be accommodated in place of other unwanted items in the spares box BW/9. For further information on the PTS/16, see Instruction S.4, Section 9.

It is in addition proposed to provide a separate trap-valve amplifier. This is for use when needed to supplement the trap-valve section of the LSM/9, or for operation at a point remote from the main stack of equipment if required. The proposed additional amplifier will have a self-contained mains unit, and will be of uniform dimension with the standard trolley-mounted items. A full description will be given in a later Section of this Instruction.

Weight of Gear

TRL/1 48 lb	MX/29 15 lb	OBA/9 15 lb	DU/1 10 lb
LSM/9 16 lb	SUP 6 32 lb	DUM/6 11 lb	LSU 11 25 lb

Interconnection Schematic

The general function of each piece of apparatus can be appreciated from the OBA/9 equipment interconnection schematic, Fig. 52.

Amplifier OBA/9 (Fig. 47)

General Description

Amplifier OBA/9 incorporates:

- (a) A microphone amplifier fitted with a control potentiometer and capable of providing a maximum gain of the order of 90 dB.
- (b) A line-up tone oscillator which, by appropriate switching, utilises the output valve of the microphone amplifier.
- (c) A peak-programme meter and amplifier.

The OBA/9 is intended to be operated from a power-supply unit SUP 6, the input to which can be taken either from internal batteries or from a.c. mains.

Microphone Amplifier

This comprises three stages, with resistance-capacitance coupling and transformer input and output. The input impedance is 300 ohms nominal to match the 300-ohm source impedance of most microphone circuits; this source im-

pedance is provided automatically when the amplifier is used with a mixer MX/29. The output impedance of the amplifier is 75 ohms, this value being suitable for working into a line the impedance of which may vary both with frequency and according to the nature of the circuit between limits of about 75 ohms and 2 kilohms.

The normal working output level and the maximum gain are similar to those of the OBA/8. Thus, as for the OBA/8, with a 600-ohm load, the normal output level of 0 dB referred to 0.775 volt is obtained with a P.P.M. reading of 4 on steady tone, the output power referred to 1 mW being then 0 dB.* Working into a 240-ohm load, the maximum voltage gain with the control potentiometer fully up is 90 dB.

The gain-control potentiometer, Type PF/5B1, is a single-gang unit arranged to vary both the degree of negative voltage feedback over V1 and V2 and also the coupling between V2 and V3. The control has 41 studs, the corresponding scale divisions being labelled 0-40. Maximum gain is obtained on stud 40, and 38 steps of 2 dB each are provided down to stud 2; there are then two larger steps down to stud 0, which provides an effective fade-out, with less than unity gain.

The amplifier is designed for a normal input level in the region of -70 dB, which for zero-level output requires a gain 20 dB below the maximum, corresponding to a setting of stud 30 on the control. Overloading of the first stage occurs if the input level exceeds -48 dB, which if the output level is to remain at zero necessitates a gain reduction of 42 dB, obtained on stud 19. (The overload point is indicated by a red line on the potentiometer scale between studs 19 and 18.) Thus, any source with a level higher than -48 dB requires attenuation before the signal reaches the grid of the first valve. Such a source is likely to have a level in the neighbourhood of 0 dB, and a 50-dB loss-pad is therefore provided in the amplifier prior to the input transformer, ready for switching into circuit if circumstances require. Further pads, with losses of 50 and 70 dB respectively, are available in the MX/29.

Fig. 47 shows the circuit arrangement of the amplifier. Negative voltage feedback is applied from V2 anode to V1 cathode circuit via C12 and the PF/5B1. The lower end of the control is returned to earth via R8, and the output from V2 to V3, which is dependent upon the potentiometer setting, is tapped off via C4 and passes to V3

grid via a section of the *Oscillator* switch, SW B, and C14, R49. With the arrangement adopted, movement of the potentiometer slider away from the earthy end simultaneously increases negative feedback over V1 and V2 and increases attenuation between V2 and V3, both actions having the effect of reducing the amplifier gain. Furthermore, since the anode resistance of V2 is shunted by the feedback circuit, the total anode load of the valve is reduced progressively as the gain is lowered, to a negligible extent at first, but increasingly as the *Off* position is approached, and is finally composed, in effect, of the low resistance R3 in the cathode circuit of V1. When this position is reached, there is 100 per cent negative feedback from V2 to V1, and the attenuation between V2 and V3 is sufficient to annul the step-up off the input transformer TR 1 and the gain of the output stage. The amplifier as a whole then has less than unity gain and its output is effectively nil in normal conditions of use.

The form of gain control described is advantageous where, as in the present instance, it is necessary to fade smoothly from maximum gain to 'off'. In an amplifier of the type required, a difficulty in the design, without involving the introduction of additional stages, is to obtain sufficient gain to enable adequate negative feedback to be applied to the early stages under maximum-gain conditions when the feedback requirements of the output stage, e.g., in respect of output impedance, have been met. This makes it desirable that negative feedback should be increased as gain is reduced, and the performance of the amplifier correspondingly improved at the lower gain settings used for the greater part of the time. The scheme suggested is by no means new and was, in fact, employed in amplifier OBA/8. A feedback control alone cannot, however, be made to give the complete fade-out required, whereas with the arrangement now adopted feedback and attenuation are simultaneously controlled in a simple manner which avoids the use of a bulky and expensive double fader.

At maximum gain, the feedback over V1 and V2 causes a gain reduction of 12 dB, the feedback at lower gain settings being considerably greater. The negative feedback for the output stage is obtained from a tertiary winding on the output transformer, TR 2, and reduces the gain of this stage by 18 dB.

A monitoring output is provided in a low-

*Originally, a load of 240 ohms and an output power of +4 dB were specified

impedance part of the circuit, this arrangement preventing the characteristics of the monitoring apparatus from having any appreciable effect on the main output.

With the maximum gain setting, the total harmonic content in the output, measured on tone at +12dB (i.e., at 4dB above programme peaks), is less than 1 per cent over the frequency range 50 c/s to 10 kc/s, and the response is flat to within 0.5 dB over this range. This performance is maintained for changes in load impedance between 75 ohms and 2 kilohms, and for usual voltage variations of batteries or mains. At the normal gain setting of about 70dB, an improved performance is obtained owing to the greater amount of feedback applied. (It should be noted that the parallel combination of C14 and R49, between V2 and V3, provides a small amount of top-lift to compensate for stray-capacitance losses arising from the fact that neither end of the amplifier gain control is at earth potential.)

The noise output at maximum gain varies between 36 and 40dB below normal output, depending upon the valve selected for use in the first stage; this noise is between 7 dB and 3 dB above the thermal agitation noise of the input circuit. At 70dB gain the noise separation is at least -50dB, and is usually better than -55 dB.

To minimise hum, special measures have been adopted with regard to the heater supply to the first stage. With an a.c. heater supply, very good heater-cathode insulation would be required to keep down hum at maximum gain, since the value of the feedback resistor R3 in V1 cathode circuit is from this point of view rather high. A proportion of valves of the type used are unsatisfactory in this respect, but the difficulty has been overcome by incorporating a circuit in the SUP/6 mains unit to provide V1 heater with a rectified and smoothed supply.

Line-up Tone Oscillator

The output stage V3 of the microphone amplifier can be converted into a line-up tone oscillator by operation of the *Oscillator* switch (Fig. 47: SW B). A cathode-coupled circuit is used, giving an output of 1,150 c/s at normal level. A thermistor, TH 1, in the anode circuit acts as a limiting element and stabilises the output level with respect to supply voltage changes. A variable resistor, R38, in series with the thermistor gives an output-level adjustment of ± 2 dB.

When SW B is operated, the input circuit of

V3 is disconnected from the output of V2 and returned to earth via the frequency-determining circuit L1, C8; V3 cathode is connected to L1 centre-tap via R37. Another contact of SW B connects C13, TH 1 and R38 between the anode and the cathode of V3.

Automatic cathode bias continues to be provided by R15, but the normal grid-leak, R14, is effectively replaced by R49. An antiparastic resistor, R46, remains in circuit, and serves to damp out oscillations in undesired modes.

Fig. 20.3 is a greatly simplified circuit diagram of the oscillator. In a valve circuit with an un-decoupled cathode impedance and an earthed grid, the feedback would normally be negative; in this circuit, however, the feedback becomes positive at one particular frequency owing to the

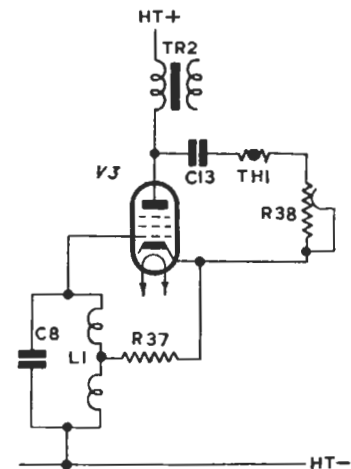

Fig. 20.3 OBA/9 Oscillator Stage: Simplified Circuit

phase-reversing action of the network L1-C8-R37: the circuit therefore oscillates at this frequency. Advantages of the arrangement are a good frequency stability and an absence of harmonics and noise in the output.

Although there is a resemblance to a cathode-coupled Hartley circuit, the behaviour is in fact somewhat modified by the facts that the two sections of L1 have equal inductance and that a resistor is interposed between the tapping point and the valve cathode. A detailed examination of this type of circuit has appeared elsewhere.*

* Roddam, T. "Chameleon" Oscillator. Versatile Modified Hartley Circuit Giving High Frequency Stability. *Wireless World*, Vol. 60, No. 2 (February 1954), pp. 52-55.

Peak Programme Meter Amplifier

A programme signal rectified by V4 is applied in a negative sense to the grid of the variable-mu pentode V5, which is operated under conditions which give an approximately logarithmic V_g/I_a law with grid-circuit time-constants of 2.5 milliseconds for charge and 1 second for discharge. The built-in meter, connected in the anode circuit of V5, has a right-hand no-current zero and is calibrated in six divisions, each of 4 dB.

Although the basic principles of the standard BBC method of programme-volume measurement are retained, the circuit differs in detail from those previously used. The changes have been made partly to suit the variable-mu valve, which is an EF41 instead of an AC/VP1, and partly to reduce variation of the characteristics caused by supply-voltage changes and by replacement of valves. With an EF41, the best performance is obtained if the impedance of the anode, screen and cathode circuits is kept low. A metal rectifier is employed to stabilise the screen voltage, since no suitable neon is available. The cathode-bias voltage, which is made variable to provide a meter zero control, is obtained from the d.c. heater supply to V1. The zero-control potentiometer is mounted on the OBA/9 face-plate, and is labelled *P.M.*

The meter 'law' is normally unaffected by valve changes, and as no adjustment is provided it may occasionally be necessary to reject a valve which does not conform.

The *Sensitivity* control is a pre-set potentiometer, R27, mounted inside the case, and should not require attention unless V5 is changed. The control is adjusted to give a *P.P.M.* reading of 4 when tone at zero voltage level is delivered by the microphone amplifier or oscillator into a 600-ohm load; this level corresponds to 0 dB power referred to 1 mW. A switch, marked *P.P.M.*, on the front of the amplifier, permits the insertion of a 4-dB pad, R50—R52, in series with the *Sensitivity* control; with this loss-pad in circuit, the voltage level on tone with a *P.P.M.* reading of 4 is +4 dB, corresponding to a power output of +4 dB into 600 ohms. The two positions of the *P.P.M.* switch are marked respectively 0 and +4.*

The need for inserting a buffer stage between the microphone amplifier and the *P.P.M.* amplifier is avoided by connecting the *P.P.M.* rectifier transformer TR 3 across the feedback winding of TR 2 where the impedance is less than a third of

the total output impedance of the microphone amplifier, and additional separation is obtained by the insertion of a resistance network between the two transformers. With this arrangement the rectifier V4 has no perceptible effect on the performance of the microphone amplifier and, as the *P.P.M.* circuit is fed from a low-impedance source, the meter reading is nearly proportional to the e.m.f. of the amplifier output circuit, any variation in the line impedance having little effect.

P.P.M. and Oscillator Calibration

- (i) With the *Oscillator* switch at *Off*, and no input applied to the OBA/9, adjust the meter to zero by means of the *P.M.* control on the front of the amplifier.
- (ii) Check that the *Input* switch is at *On*, and apply 1-kc/s tone to the OBA/9 input, at a level of about -70 dB. Connect a load resistance of 600 ohms, and adjust the amplifier gain to obtain zero level volts output, measured with a high-impedance instrument across this load.
- (iii) With the *P.P.M.* switch at 0, adjust the *Sensitivity* control to make the meter read 4.
- (iv) With the same load, vary either the input level or the gain in 4-dB steps (i.e., two divisions at a time on the gain-control scale) and check the 'law'. If there is appreciable error, the variable-mu valve V5 may be unsuitable, and should be replaced. (It should normally be necessary to reject only some 5 per cent of specimens tried).
- (v) Remove the input connection, and set the *Oscillator* switch to *On*. Adjust the oscillator level control on the left of the switch until the *P.P.M.* reads 4 with a 600-ohm load.

Mechanical Construction

The amplifier is constructed on a chassis attached at right-angles to the face-plate. Aluminium alloy is used and the chassis is braced by two rods which enable the amplifier to rest upside-down on a bench without damage to components. With the amplifier in its case, these rods rest against projections in the wall of the case as do also the outer bottom edges of the chassis. This construction supports the amplifier against the shocks of transport.

Most of the smaller components and wiring are

* The switch was originally marked +4 and +8, the output powers into 240 ohms.

below the chassis and are protected by a sheet of bakelised canvas. The first-stage valve is mounted on a small platform attached to the chassis with resilient rubber fastenings. This platform also carries the input transformer, thus giving extra mass to the assembly and improving the mechanical filtering effect. With this arrangement, microphony in the amplifier is very low.

All programme connections are on jacks, and the input and main output are also brought out to screw terminals provided with earth-clips for the cable screens. There is provision for connecting an external meter in series with the built-in programme meter; although it is normally convenient to connect any external meter via a break-jack, screw terminals are also fitted, together with a shorting-switch for use when these terminals are not required.

Valve Data : OBA/9

Valve	Anode Current mA	Screen Current mA	Heater Volts	Heater Amps
Mic. Ampr.				
V1 : EF37A	0.45	0.1	5.0	0.2
V2 : EF37A	1.0	0.3	6.1	0.2
V3 : CV138	6.0	2.0	6.1	0.3
P.P.M. Ampr.				
V4 : EB41			6.1	0.3
V5 : EF41		3.2	6.1	0.2

Supplies

H.T. supply, 250 volts, 15 mA.

L.T. supplies, 6.1 volts, 1.0 amp a.c. or d.c.; 5 volts, 0.2 amp d.c.

NOTE.—The valve data refer to a mains-derived supply from an SUP/6, with no input signal applied. When the feed meter is switched to V1, V2 or V3, it indicates the anode current only; when switched to L.T., it indicates V1 heater voltage. (N.B. When supplies are derived from the SUP/6 batteries, it must be remembered that the indicated L.T. voltage of V1 is only about 83 per cent of the l.t.-battery voltage.)

General Data : OBA/9

Impedances

Normal source $Z = 300 \Omega$
 Input $Z = 300 \Omega \pm 15\%$ at 1 kc/s
 Output $Z = 75 \Omega \pm 10\%$, 60 c/s to 8 kc/s
 Normal load $Z =$ Between 75 Ω and 2 k Ω

Normal Input Level

— 70 dB.

Normal Output Level

0 dB referred to 0.775 volt.

Normal Output Power

With 600- Ω load.

0 dB referred to 1 mW.

Maximum Input Level

— 48 dB.

Gain Control Potentiometer

Type PF/5B1

Total number of studs, 41.

Scale engraved 0-40.

Stud 40 gives maximum gain.

Studs 39-2 give 38 steps, each with a loss of 2 dB.

(Tolerance, per stud and cumulative, ± 0.3 dB)

Studs 1-0 give 2 larger steps to effective Off position.

Test Data : OBA/9

Maximum Voltage Gain

Measured at 1 kc/s with 240- Ω load.

$G = 90 \pm 1.5$ dB.

Monitor Output

Test frequency, 1 kc/s.

Level at main output, 0 dB (volts) into 240 Ω .

Level at monitor output, measured with high-impedance amp. det., -2 ± 1 dB.

NOTE.—If monitor output is short-circuited, the level at main output should not fall by more than 0.2 dB.

Frequency Response

± 0.5 dB from 50 c/s to 10 kc/s.

± 1.0 dB from 30 c/s to 15 kc/s.

Percentage Total Harmonic Distortion

Output level, + 12 dB (volts) into 240 Ω .

At 60 c/s, < 1.0%.

At 1 kc/s, < 0.5%.

Originally issued as page 20.7 of S.3.

INSTRUCTION S3

Section 20

Page reissued August 1961

Noise Volume

Input termination, 300 Ω ; load, 240 Ω .

Noise volume (unweighted), not greater than -36 dB at maximum gain, and not more than -50 dB at 70 dB gain (stud 30).

Line-up Tone Oscillator

Frequency, 1,150 c/s \pm 5%.

Output level, adjustable over range, normal \pm 2 dB.

Supply Unit SUP/6 (Fig. 48)

General Description

Supply unit SUP/6 is designed to feed two OBA/9 amplifiers simultaneously, one from a mains unit and the other from batteries. Normally, the amplifier used for transmission is supplied from the mains, and the standby amplifier from the batteries. A switch permits the interchange of mains-derived and battery supplies between the amplifiers, and a further switch allows the battery supply to be discontinued when not required. It is not possible to connect both amplifiers to the same supply.

A terminal and control panel is mounted centrally on the front of the apparatus, with the mains unit behind it, and the batteries disposed in covered recesses on either side. The supplies for the two amplifiers are brought out to the panel on 6-pin cable-connectors. The earthing terminal of the SUP/6 is connected to h.t. negative and serves as a common earth point for the complete set of O.B. gear; the earth connection to each amplifier is made via the respective power-supply cable and is extended to the remaining apparatus via sleeve circuits.

The common earth point is brought out to the third pin of the SUP/6 mains connector in parallel with the screw earthing terminal. (Fig. 48.) Normally, where a 3-pin mains-supply socket is available at the O.B. site, the earth connection is made via the third pin of this socket and the SUP/6 mains cable and mains connector. Where only a 2-pin socket is available at the site, the screw terminal on the SUP/6 must be connected to a suitable earth point; for this purpose, if necessary, an earth pin must be driven into the ground. All equipment in use on the site must be earthed to the same point.

Mains Unit

The supplies provided by this unit are as follows:

- (a) H.T. supply, 250 \pm 10 volts, 15 milliamps.
- (b) L.T. a.c. supply, 6.1 \pm 0.2 volts, 1.0 amp.
- (c) L.T. d.c. supply, 5.0 \pm 0.2 volts, 0.2 amp.

The primary winding of the mains transformer is tapped for input voltages of 250, 235, 220 and 205; the tapping switch has also an *Off* position. A voltmeter and a neon indicator-lamp are fitted on the mains side of the switch, and a pair of fuses is also provided. The equipment can be used with a supply of any frequency between 45 and 60 c/s.

Fig. 48 shows the circuit arrangement; it will be seen that metal rectifiers are used for both the

d.c. supplies. The h.t. supply is obtained from MR 2 and MR 3, and is smoothed by C1, R1 and C2; the use of metal rectifiers instead of a valve rectifier for this supply reduces heat dissipation and thus improves the life of the batteries and electrolytic capacitors. The l.t. d.c. supply, which is required for the heater of the first-stage valve in the OBA/9, is obtained from the bridge rectifier MR 1 and is smoothed by the 2,000- μ F capacitor C3.

Batteries

The battery details are as follows:

- (a) H.T. battery. 240 volts nominal. Comprises six Ever Ready 'Batrymax' Type-B104 45-volt dry batteries. Initial open-circuit voltage, 270 volts. Normal voltage on load, about 245 volts falling to 215 volts after 20 hours or more of intermittent use; the battery should be rejected when the on-load voltage falls below this latter figure.
- (b) L.T. battery. This is a 6-volt dry accumulator comprising three Varley Type-VPT 9/14 cells in a waxed wooden box. The capacity at the required discharge rate of rather less than 1.2 amps is about 10 ampere-hours, so that the battery can be used for some eight to nine hours before it needs to be recharged.

Reactivation of H.T. Battery

A circuit is provided for reactivating the h.t. battery by charging it in a similar manner to accumulators; investigation* shows that a considerable increase in battery life can be obtained in this way. The mains-derived charging supply is taken from the reservoir capacitor C1, where a suitably high voltage is available. All the time the mains unit is switched on a trickle charge is given, limited by R3 to 1 or 2 milliamps depending on the state of the battery. When the mains unit is switched off, the metal rectifier MR 4 prevents the battery from discharging through the final-valve screen circuit of the mains-operated amplifier. The smoothing capacitor C4 ensures that no a.c. ripple is fed into the battery and its associated amplifier.

Mixer MX/29. (Fig. 49)

This is a four-channel unit with variable-impedance balanced series faders. Two input jacks are provided for each channel; one is for use with a ribbon microphone and connects

* Designs Department Test Report No. 23.

directly to the fader, whereas the other is for use with a moving-coil microphone and connects to the fader via a 30/300-ohm transformer.

Two loss-pads, with attenuation of 50 dB and 70 dB, are provided for use in attenuating high level inputs, such as may be obtained from a sub-control point, to a level suitable for mixing with the outputs from local microphones.

General Data : MX/29

Impedances

Normal source	Z = 30 Ω (m.c.), 300 Ω (ribbon).
M.C. input	Z = 36 $\Omega \pm 10\%$ at 1 kc/s with normal load Z.
Ribbon input	Z Variable.
Output	Z Variable.
Normal load	Z = 300 Ω .

Insertion Loss

Moving-coil mic. channel, 30/300 Ω , < 1.5 dB.
Ribbon microphone channel, 300/300 Ω , 0 dB.

Crosstalk Ratio

With one channel faded out and fed with 5-kc/s tone at 0 dB, the mixer output due to crosstalk when all other channels are faded up should not be greater than - 100 dB.

Fade Units

Type PZ/7M1

Number of studs, 22.

Loss per stud :

21	20-15	14-11	10-7	6-4	3-2	1	0	
0 dB	1.5 dB	2 dB	3 dB	4 dB	6 dB	7 dB	∞	
Maximum input level, 1 volt r.m.s.								

Fixed Attenuators

Impedances, 300 Ω .

Loss, 50 ± 1 dB and 70 ± 1 dB.

Distribution Unit DU/1 (Fig. 50)

This unit provides programme and communication switching facilities commonly needed in O B practice. It is designed to accommodate:

- The outputs of two OBA/9 amplifiers.
- Two outgoing lines (i.e., one music and one control).

- Control telephone
- Three local lines
- Two input channels for the local lines
- One two-way cue-light circuit.

Provision is made for the following operations :

- Normal/reserve change-over on the OBA/9 amplifiers.
- Music/control change-over on outgoing lines.
- Switching the three local lines for feeding cue signals or programmes (e.g., from the local distribution or from a check receiver) to sub-control points or microphone sites ; the lines can also be used as a local telephone network, with access to the outgoing control line.
- Switching the control-point telephone to local or outgoing lines, or to both. A drop indicator gives recall facilities on an unoccupied telephone channel.
- The exchange of cue-light signals with a distant communication unit CMU/9. The necessary supply for the lamps, at either 6.3 or 8 volts according to line resistance, is provided by the mains unit of the LSM/9.

The detailed arrangements are shown on the DU/1 circuit diagram, Fig. 49, and on the OBA/9 equipment interconnection schematic, Fig. 52.

Amplifier LSM/9 (Fig. 51)

General

The LSM/9, Fig. 51, comprises a loudspeaker amplifier V1-V3 and V6, and a trap-valve amplifier V4. The inners of the input jack on the T.V. amplifier are connected to the outers of the corresponding jack on the L.S. amplifier, so that only one cord is needed for feeding both amplifiers with the same programme.

A built-in power-supply unit is provided, incorporating a mains transformer, TR5, and an h.t. rectifying valve, V5. A cue-light supply at either 6.3 or 8 volts a.c. is also provided.

Although it is intended that the power-supply shall normally be mains-derived, provision is also made for using external batteries, a "battery" power-input socket and switch being fitted for use when a suitable mains supply is not available.

A feed meter, with an associated selector switch, is provided; there is also a set of three paralleled jacks, with a pair of terminals, for miscellaneous testing or programme routing.

INSTRUCTION S.3
Section 20

Loudspeaker Amplifier

This is a two-stage (four-valve) amplifier with input and output transformers. At maximum gain it produces 4 watts output for an input of -7 dB (on steady tone); since, however, this gain may be inconveniently high for normal use, a 10-dB loss pad and shorting switch are connected between the secondary of the input transformer and the gain control which precedes the first stage.

The first stage consists of V1 and V6 which form a cathode-coupled phase-splitting circuit to give a push-pull drive for the output stage V2 and V3. In the original LSM/9 phase-splitting was carried out by employing cathode coupling in the push-pull

carried out in the first stage since a cathode-coupled phase-splitting circuit can only operate in Class A.

The first valve, V1, has voltage negative feedback from the secondary of the output transformer via the network R41, C6 and R42, R2. R41, C6 and R44, C11, R5 are components introduced to alter the loop gain/frequency characteristic of the amplifier at frequencies above the audio range, to prevent the feedback causing instability. R46 and C16 were included to reduce the effect on the loop characteristic of varying impedance at the secondary of the input transformer TR1. The application of feedback results in an output impedance of about 2 ohms being presented to the LSU/11, and as the speech coil impedance is 12 ohms nominal, satisfactory damping is thus obtained.

The cathode-coupled phase-splitting circuit of the first stage is shown in simplified form in Fig. 20.4. A detailed analysis of this type of circuit has appeared in the *Wireless Engineer*,* and only a brief account will be given here.

The two valves V1 and V6 have a common biasing resistor R8, the grid bias being applied to the grids by the gridleaks R10 and R11 respectively. A further common cathode resistor R9 provides coupling between the two valves but because of the capacitors C3 and C4 has no effect on the grid bias.

Consider first the operation of V1 alone. The signal input to this valve is applied across R10 via R9. V1 cathode current flowing through R9 develops across this resistor a voltage in opposition to the original signal; this voltage is of suitable phase to provide the inverted signal input required for V6. With this signal now applied to V6, the cathode current of this valve also flows through R9 but in antiphase to that of V1.

If the two valves had equal inputs, and were perfectly balanced, their cathode currents would also be equal and no resultant voltage would appear across R9. In this event, there would be no input to V6, and so, in practice, the cathode currents of the two valves must adjust themselves to unequal values, that of V1 being the greater. The closeness of balance obtained at the output between the two sides improves as the value of R9 is increased, but the presence of a d.c. voltage drop across this

* AMOS, S. W. "Push-pull Circuit Analysis". *Wireless Engineer*, 23, No. 269 (February, 1946), pp. 43-46.

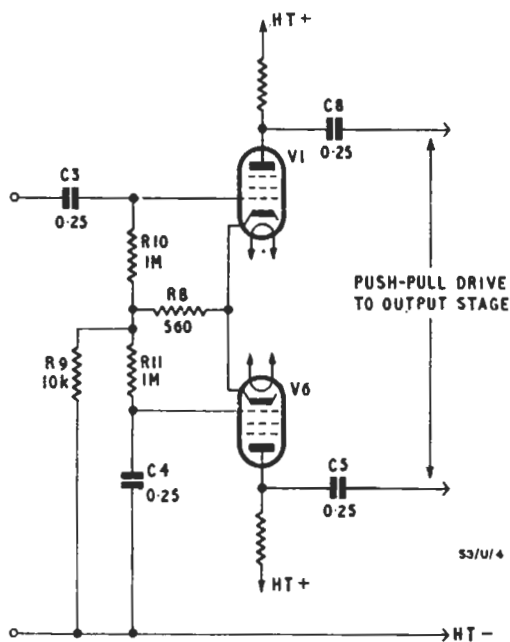

Fig. 20.4 LSM/9 First Stage: Simplified Circuit

output stage itself, and a single valve was employed in the first stage. The maximum output level obtained with this arrangement was $+12$ dB, and it was found that for adequate loudspeaker volume in exceptionally noisy locations a maximum output level of $+20$ dB was desirable. The amplifier was therefore modified to use larger output valves which are operated in Class AB to economise on power supply; it was then possible to retain the original mains transformer and rectifier circuits, and to operate from a battery supply if necessary. Valve V6 was added to enable phase splitting to be

resistor necessitates a compromise depending upon the voltage of the h.t. supply. The circuit can be operated only in Class A.

The push-pull output stage is biased to Class AB by means of the battery of six cells. The quiescent anode current of V2 and V3 is thus reduced to approximately 10 mA each, rising to approximately 20 mA at 4 watts output. The resistors R20 and R40 prevent an excessive rise of cell current even when the amplifier is grossly overloaded by a steady-tone signal.

An output *Listen* jack, fed via two 47-ohm series resistors may be used as a source of programme for cueing purposes. This output should not be used when the highest quality is required, since the load provided by the loudspeaker itself affects the frequency response.

Trap Valve Amplifier

The trap valve is a single cathode-follower stage with input and output transformers. The input impedance is about 8 kilohms, and the impedance at the secondary of the output transformer is 28 ohms. Three output jacks are provided, in series with each of which is a resistance of 112 ohms; the output impedance at any one jack with the remaining jacks on open circuit is thus 140 ohms; any two outputs are separated by the equivalent of a 20-dB pad, and if one output is short-circuited, the fall in level at the others cannot exceed 2 dB. The maximum gain between 600-ohm terminations is about 1.5 dB. The maximum output level into 600 ohms is +10 dB, with a total harmonic distortion at 1 kc/s of 0.5 per cent. The frequency response is flat to within 0.25 dB between 50 c/s and 10 kc/s.

A volume control is fitted between the input transformer and the grid of the valve. The cathode follower itself produces less than unity gain, and the amplification obtained is due to a 2:1 difference in the ratios of the transformers. (See Fig. 51).

The trap valve is intended primarily for feeding miscellaneous services, such as recording and public-address equipment, with programme at up to zero volume. The input should be taken from the OBA/9 monitor output, when the maximum output obtainable from the trap valve will be about zero volume.

Valve Data: LSM/9

Valve	Anode Current mA	Screen Current mA	Heater Volts	Heater Amps
L.S. Ampr.				
V1: CV 138	1	0.2	6.3	0.3
V6: CV 138	1	0.2	6.3	0.3
V2: N 78	*10	*2.0	6.3	0.3
V3: N 78	*10	*2.0	6.3	0.3
T.V. Ampr.				
V4: CV 138	8.0		6.3	0.3
Rectifier				
V5: 6X5GT			6.3	0.6

* No signal condition

Supplies

H.T. supply, 285 volts, 37 mA,
L.T. supply, 6.3 volts, 2.2 amps a.c.
Cue-light supply, 6.3 or 8 volts a.c.

NOTE.—The valve and supply data relate to the use of the built-in mains unit and not to the emergency external-battery supply. H.T. feeds indicated by meter are anode currents only.

L.S. Amplifier Data

Impedances

Input $Z = 10 \text{ k}\Omega \pm 20\%$ at 1 kc/s
Output $Z = 1.7 \Omega \pm 20\%$ at 1 kc/s
Normal load $Z = 12 \Omega$ nominal (LSU/11).

Maximum Input Level

+10 dB.

Maximum Output Level

+20 dB.

Maximum Voltage Gain

Frequency 1 kc/s, load 12 Ω resistive.

Gain $G = 27 \text{ dB}$.

Frequency Response

$\pm 0.5 \text{ dB}$ from 30 c/s to 15 kc/s.

Percentage Total Harmonic Distortion

Output level +20 dB, load 12 Ω resistive.

At 60 c/s, < 1%.

At 1 kc/s, < 1%.

Noise Volume

Volume control at maximum, input termination 600 Ω , load 12 Ω .

Maximum noise volume (unweighted), — 53 dB.

INSTRUCTION S.3

Section 20

T.V. Amplifier Data

Impedances

Input $Z = 8 \text{ k}\Omega \pm 20\%$ at 1 kc/s.

Output $Z = 140\Omega \pm 10\%$ at 1 kc/s.

Maximum Input and Output Levels

+ 10 dB.

Maximum Voltage Gain

Frequency 1 kc/s, termination 600/600 Ω

Gain $G = 1.5 \pm 1$ dB.

Frequency Response

± 0.25 dB from 50 c/s to 10 kc/s.

Percentage Total Harmonic Distortion

Output level + 10 dB, load 600 Ω .

At 60 c/s, < 1%.

At 1 kc/s, < 0.5%.

Noise Volume

Better than - 60 dB in 600 Ω .

Loudspeaker Unit LSU/11

The LSU/11 (Fig. 20.2) comprises an 8-inch Wharfedale moving-coil loudspeaker mounted in a closed felt-lined wooden case. The nominal value of the speech-coil impedance is 12 ohms. This loudspeaker, coded 8/CS/HP.227/05 by the maker, has a high efficiency and high sensitivity, and was selected to save weight and to make the most of the moderate power (about 1 watt) available from the LSM/9.

The wooden case, Type CS/24, has a metal grille in front, protected during transport by a metal cover. An input jack and set of terminals are fitted at the rear. The external dimensions are 19 in. by 15 in. by 9 in.

Communication Units CMU/9 and CMU/10

These units are provided for lamp signalling between the control point and microphone sites. The CMU/9 (Figs. 20.2 and 20.5) comprises a red and a green lamp together with a non-locking key and terminals, and is contained in a metal box measuring $3\frac{3}{4}$ in. by $3\frac{1}{4}$ in. by $2\frac{3}{4}$ in. The CMU/10 (Figs. 20.2 and 20.6) embodies an extension P.P.M. instrument as well as three separate signal-lamp circuits similar to that of the CMU/9; the dimensions of the metal housing are 9 in. by $6\frac{7}{8}$ in. by $5\frac{1}{2}$ in. All lamps are of the 2.5-volt 0.3-amp M.E.S. (i.e., 'torch-bulb') type.

Where the signalling circuit is required between the control point and a single microphone site,

one CMU 9 unit may be used in conjunction with the signal-lamps and key provided on distribution unit DU/1 (Fig. 50). With more complicated O.B. layouts, a CMU/10 unit can be used at the control point with up to three CMU/9 units placed at different microphone sites. Other layouts may be adopted as circumstances require.

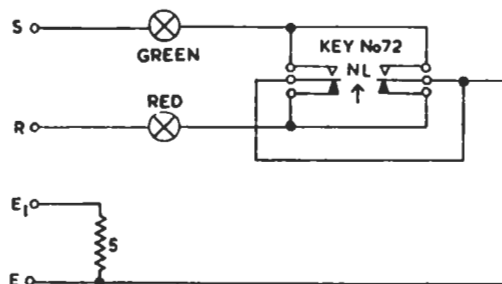

Fig. 20.5 Communication Unit CMU/9

All the lamp circuits are of the three-wire type with a local lamp and a remote lamp connected in series for each direction of signalling, so that a circuit fault is indicated at the sending end. Power at 6.3 or 8 volts may be taken from the LSM/9, or a separate battery may be used if desired. The choice of voltages available from the LSM/9 is provided to allow for different layouts, including the length of line; in addition, alternative terminals are provided for the common wire, one terminal, labelled E , being a direct connection, and the other, labelled E_1 , introducing a 5-ohm series resistance for use with a short low-resistance line to prevent the lamps from being over-run.

When the supply is derived from the LSM/9, the terminals marked E_1 on the remote units should not be used unless all three conductors of the signalling circuit are insulated from earth, as one side of the supply is earthed at the LSM/9. When a separate battery supply is used, this restriction does not, of course, apply.

The connection between units should be made from S to R , R to S and E to E , the terminals marked E_1 being used instead of those marked E when circumstances require. The power supply should be connected in series with the common line; the DU/1 is fitted with a plug for this purpose, and the CMU/10 a plug in parallel with a pair of terminals. As the CMU/9 is normally used in conjunction with either the CMU/10 or the DU/1, no direct power-supply connection to it is required.

If it is desired to establish a signalling circuit between the DU/1 and a CMU/10, then provided that no CMU/9 units are employed, the power supply can be taken to either end of the circuit

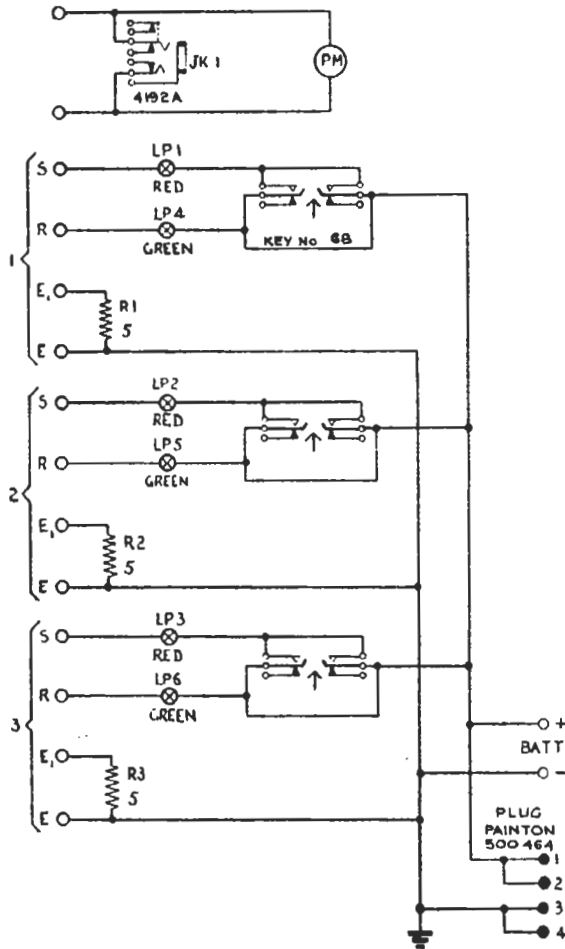

Fig. 20.6 Communication Unit CMU/10
as convenient, the supply connection at the other end being short-circuited. If, however, the CMU/10 is connected not only to the DU/1 but also to either one or two CMU/9's, the supply must be taken direct to the CMU/10, and the signalling-circuit supply connection on the DU/1 short-circuited. The requirements of the more elaborate arrangements occasionally needed should be worked out from the various circuit diagrams.

Communication Unit CMU/10A

The CMU/10A is similar to CMU/10 but has a P.P.M. calibrated for use with the P.P.M. valve of the OBA/9A.

Miscellaneous Equipment

Cable Drums DUM/6

Three cable drums Type DUM/6 (flange diameter 10½ in., total width 3⅝ in.) are provided as standard with each set of gear. Each drum carries 150 ft of RSF2/2 screened microphone cable, with the inner end terminated at a jack in the hub of the drum. The drums are intended to be mounted axially on pegs at the rear of the O.B. trolley, so that the cable can be paid out and later rewound (using a handle supplied) without removing the drum.

Spares Box BW/9

This is a wooden box (Fig. 20.2) measuring 19 in. by 10¾ in. by 9 in., fitted with six baize-lined compartments and a removable wooden tray. It is intended to accommodate the telephone set, the three CMU/9's, spare valves, all necessary cords and power cables and any small accessories.

Waterproof Canvas Covers

A suitable canvas cover is available for the trolley-mounted stack of apparatus, and is normally supplied with the gear. Specifications exist of covers for the individual standard-sized units and for the supply unit SUP/6; these additional covers are not normally provided, but can be supplied to order where required.

Cords and Power Cables

A set of 18 single- and double-ended cords is provided as part of the standard equipment. These are listed in detail on BBC drawing No. EA 8209.

A set of eight power cables is supplied as follows:

- 1 mains cable to SUP/6 and LSM/9,
- 2 cables for OBA/9 power supply from SUP/6,
- 1 cable for DU/1 cue-light supply from LSM/9,
- 1 cable for CMU/10 cue-light supply from LSM/9,
- 1 cable for CMU/10 cue-light supply from battery,
- 1 LSM/9 battery cable,
- 1 OBA/9 battery cable.

To assist identification, the battery cables have white sheaths, and most of the others grey. Further details of the cables are shown in Fig. 53.

Amplifier OBA/9A

This amplifier is similar to the OBA/9 but has different valves. See Fig. 47, Notes 1 and 2.

COMPONENT TABLE: FIG. 47

Comp.	Loc.	Type	Tolerance per cent	Comp.	Loc.	Type	Tolerance per cent
C1	I11	T.C.C. CE32A/PVC		R27	R11	LHNAP 10250 1" Sp	
C2	H7	" CP37N/PVC		R28	R11	Erie 9	± 10
C3	H7	" CP35N/PVC		R29	R9	" "	"
C4	J10	" CP37N/PVC		R30	U8	" "	"
C5	L7	" "		R31	U9	" "	"
C6	L11	" CE32A/PVC		R32	V11	Welwyn SA3623	± 5
C7	P8	" CP47N/PVC		R33	Y6	Dubilier BTB	± 10
C8	N11	L.E.M. 2515	± 5	R34	Y11	Erie 9	± 10
C9	U10	" 3220 Filter	"	R35	Y10	Painton 2-W Pot	
C10	J5	Plessey 822/1		R36	Y9	Erie 9	± 10
C12	J6	Hunt W54 WP210		R37	O10	" "	± 5
C13	P6	T.C.C. CP37N/PVC		R38	Q8	Painton 2-W Pot	
C14	L8	" CM20N	± 20	R39	H5	" P406	± 1
C15	H8	" SCE70C/PVC		R40	K5	" "	"
L1	N10	LD/1/4S		R41	Q5	" "	"
MR1	X11	Westinghouse 16HT64		R42	V4	Welwyn SA3623	"
R1	F8	Erie 9	± 10	R43	X1	" SA3622	"
R2	H11	" "	"	R44	G7	Erie 9	± 10
R3	H9	Welwyn SA3611	± 2	R45	J7	" "	"
R4	H6	" SA3623	± 5	R46	N7	" "	"
R5	I6	Erie 9	± 10	R47	S5	" "	± 5
R6	J5	" "	"	R48	S7	" "	"
R8	I11	" "	"	R49	M9	" "	± 10
R9	J11	" "	"	R50	S9	Welwyn SA3611	± 2
R10	K11	" "	"	R51	S8	" "	"
R11	K6	" "	"	R52	T8	" "	"
R12	L6	" "	"	R53	V5	Dubilier BTB	± 10
R13	N5	" "	"	R54	X11	Erie 9	"
R14	M11	" "	"	R55	X11	" "	"
R15	P9	" "	"	SW A	C8	Oak H 4-P 3-W N.S.F.	
R16	P5	" "	"	SW B	L10 } O9 } P8 }	A.B. Metal MI 3-P 2-W	
R17	P10	" "	"	SW C	W3	" " " 2-P 6-W	
R18	C6	Welwyn SA3611	± 2	SW D	W7	Arrow D.P.D.T. 20905	
R19	C7	" "	"	SW E	S10	" " "	
R20	C6	" "	"	THI	P7	S.T.C. A5412/100	
R21	C7	" "	"	TR1	E8	LG/37SA	
R22	D6	" "	"	TR2	R6	AL/35RA	
R23	D7	" "	"	TR3	U8	LGG/3SH	
R24	C6	" "	± 5				
R25	D6	" "	"				
R26	R10	Erie 9	± 10				

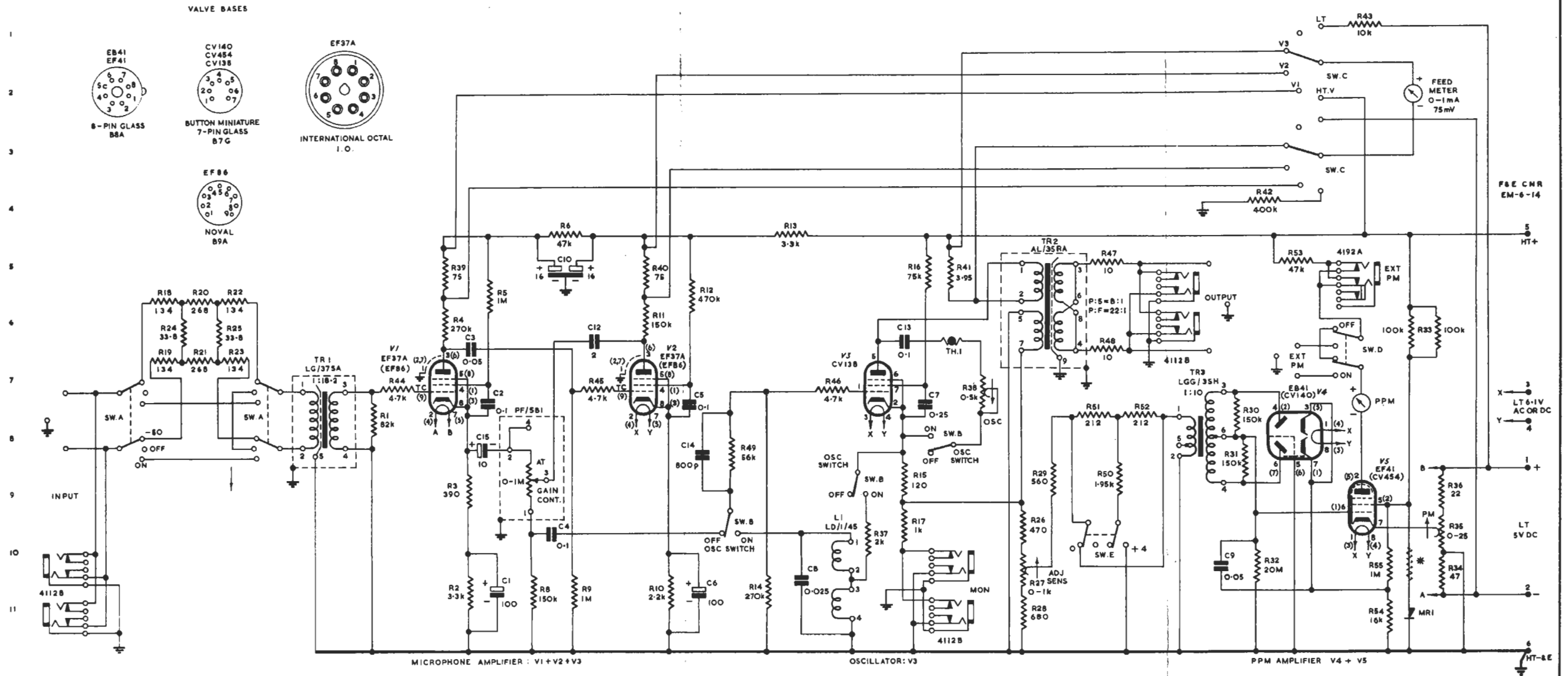

This drawing is the property of the British Broadcasting Corporation and may not be reproduced or disclosed to a third party in any form without the written permission of the Corporation.

NOTES:- 1 VALVE TYPES AND PIN NUMBERS IN BRACKETS REFER TO OBA/9A
 2 PPM METER IS TO SPEC No 1470 FOR OBA/9 & TO SPEC No 1471 FOR OBA/9A

* THIS RESISTOR TO BE SELECTED AND FITTED ON TEST WHEN NECESSARY, TO SUIT RECTIFIER MR1

AMPLIFIERS OBA/9 & OBA/9A: CIRCUIT

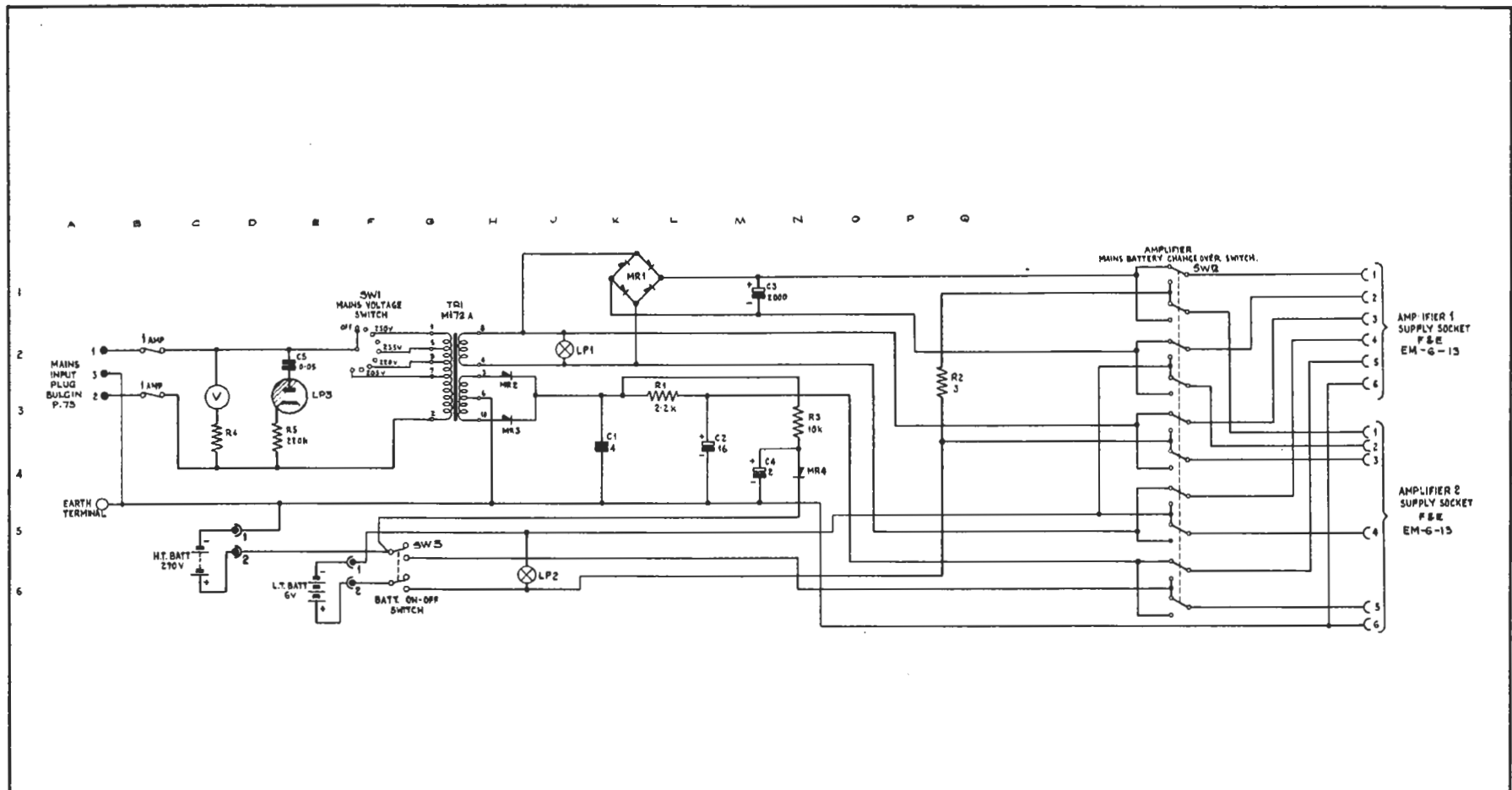

SUPPLY UNIT SUP/6: CIRCUIT

FIG 48
ISSUE 2

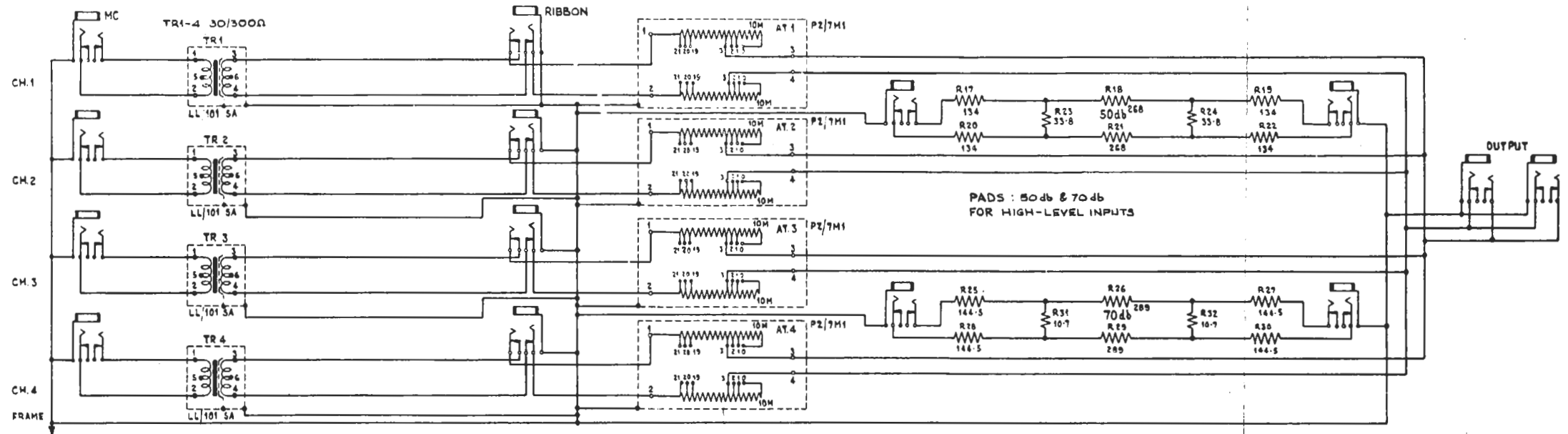

MIXER MX/29: CIRCUIT

This drawing is the property of the British Broadcasting Corporation and may not be reproduced or disclosed to a third party in any form without the written permission of the Corporation.

ISS	CHANGE
2	C1 & C2 ADDED

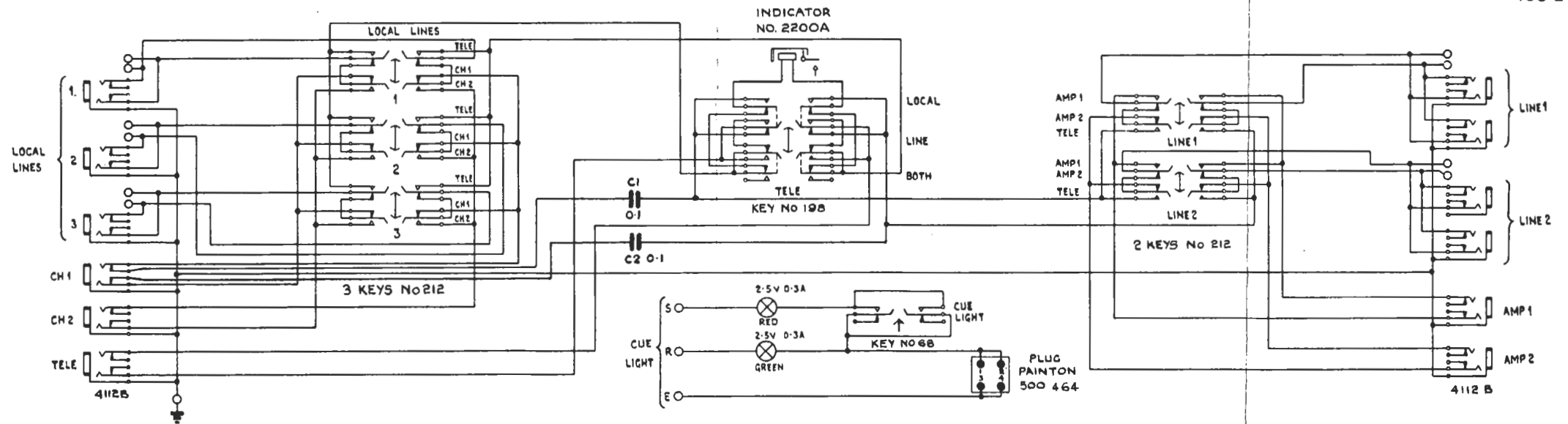

DISTRIBUTION UNIT DU/1: CIRCUIT

COMPONENT TABLE; FIG. 51

Comp.	Loc.	Type	Tolerance	Comp.	Loc.	Type	Tolerance
C1a	E3)	Plessey CE822/1		R23	B1	Morganite H, log, $\frac{7}{8}$ " Sp.	
C1b	C1)			R24	C2	Erie 9	± 10%
C2a	L2)	Plessey CE821/1		R25	C2	" "	"
C2b	P1)			R26	C2	" "	"
C3	C4	Hunt B501K		R27	E1	Dubilier BTB	"
C4	E5	Hunt B501K		R28	F1	Erie 9	"
C5	F5	Hunt A313		R29	F1	" "	"
C6	C5	T.C.C.SM3N	± 20%	R30	F1	" "	"
C7	J4	T.C.C.CSM20N	± 5%	R31	F2	" "	"
C8	F3	Hunt A313		R32	F2	" "	"
C9	H4	T.C.C.SCE79B/PVC		R33	F2	" "	"
C10	H4	T.C.C.SCE79B/PVC		R35	F3	Painton F406	± 2%
C11	C4	T.C.C. CM20N	± 20%	R36	J4	" "	"
C14	C2	T.C.C. CP375		R37	H4	" "	"
C15	D3	Plessey CE17069/1		R38	L1	" "	"
C16	B5	T.C.C. CM20N	± 20%	R39	H2	Welwyn C23	"
R1	B3	Erie 9	± 10%	R40	F4	Erie 9	± 10%
R2	A5	" "	"	R41	C5	" "	"
R3	B4	" "	"	R42	B5	" "	"
R4	B4	Morganite H, log, $\frac{1}{8}$ " Sp.		R43	F3	" "	"
R5	C4	Erie 9	± 10%	R44	D3	" "	"
R6	C3	" "	"	R45	J5	" "	"
R7	D3	" "	"	R46	A4	" "	"
R8	D4	" "	"	R47	Q2	Painton MW1, 1½W	± 5%
R9	D5	" "	"	SWA	Q4	N.S.F. 8373/B145	
R10	C5	" "	"	SWB	R4	" "	
R11	G5	" "	"	SWC	G1)	" "	
R12	E3	" "	"		M2)	" "	
R13	E4	" "	"	SWE	P1)	" "	
R14	G4	" "	"		R2)	" "	
R15	G5	" "	"	SWE	M1	EPA8020	
R16	G5	" "	"	SWF	U1	EPA8019	
R17	G3	" "	"	SWG	B3	EPA7602	
R18	G4	" "	"	TR1	A4	LG/75A	
R19	G4	" "	"	TR2	K4	AAL/22R	
R20	F4	Painton MW1, 1.5W	± 10%	TR3	A1	LG/415A	
R21	M5	Erie 9	± 10%	TR4	D2	AL/375A	
R22	M5	" "	"	TR5	S1	M.173	

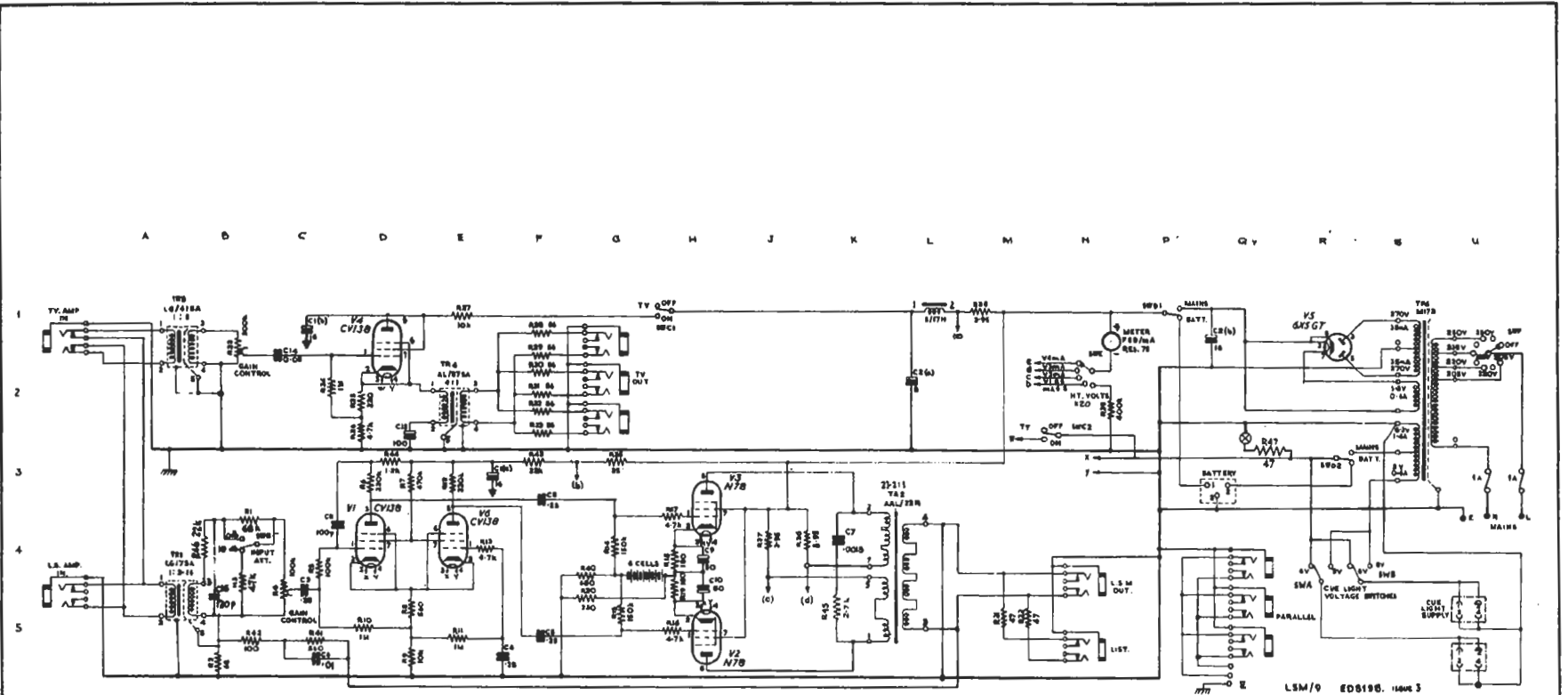

LSM/9 EDB196, 11004 3

VALVE BASES

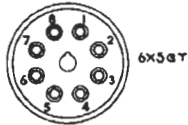

Button Mounting
7-pin Glass
B7C.

INTERNATIONAL OCTAL
IO

AMPLIFIER LSM/9: CIRCUIT

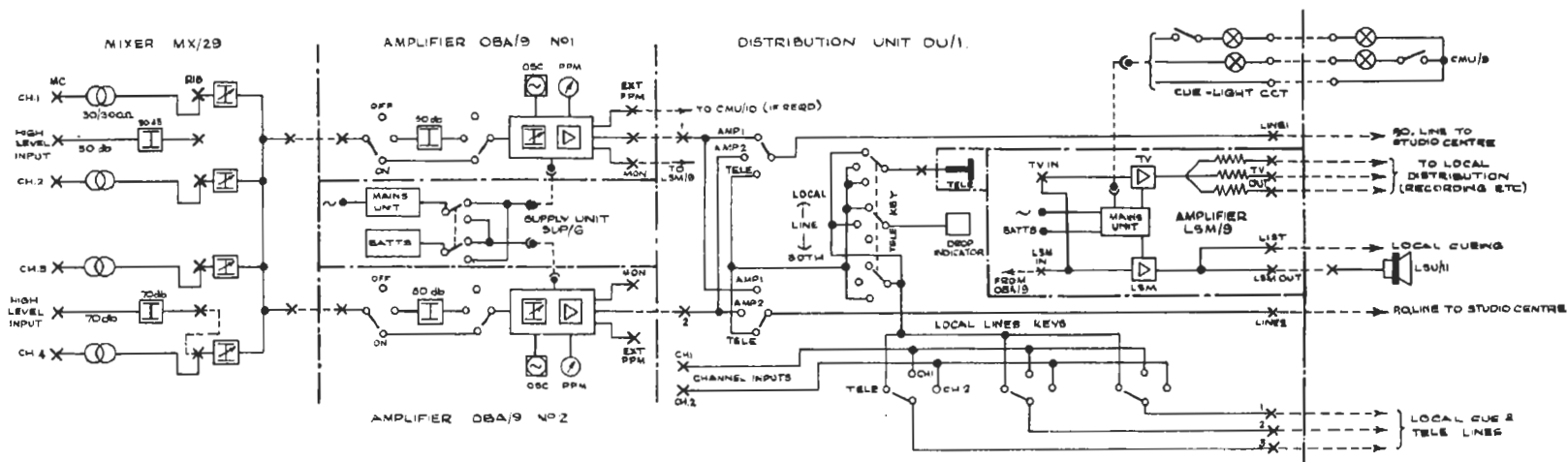

OBA/9 EQUIPMENT : INTERCONNECTION SCHEMATIC

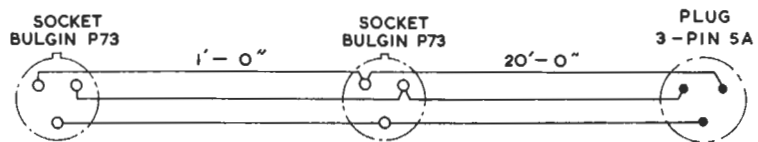

MAINS CONNECTOR

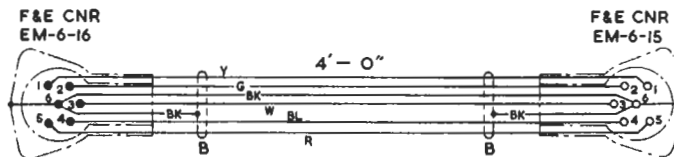

OBA/9 SUPPLY CONNECTOR

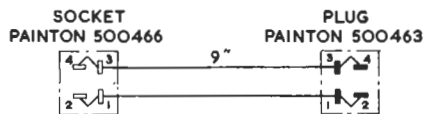

DU/1 CUE LIGHT SUPPLY CONNECTOR

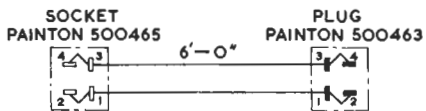

CMU/10 CUE LIGHT SUPPLY CONNECTOR

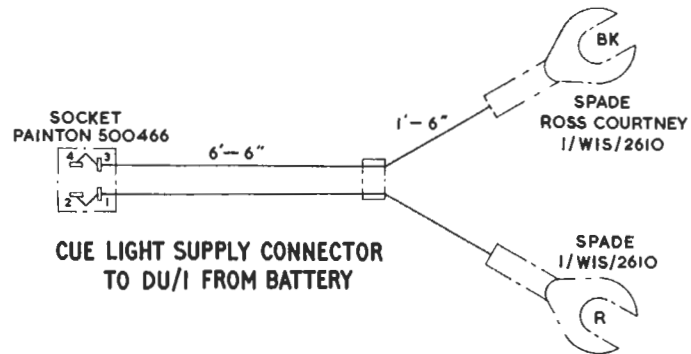

CUE LIGHT SUPPLY CONNECTOR TO DU/1 FROM BATTERY

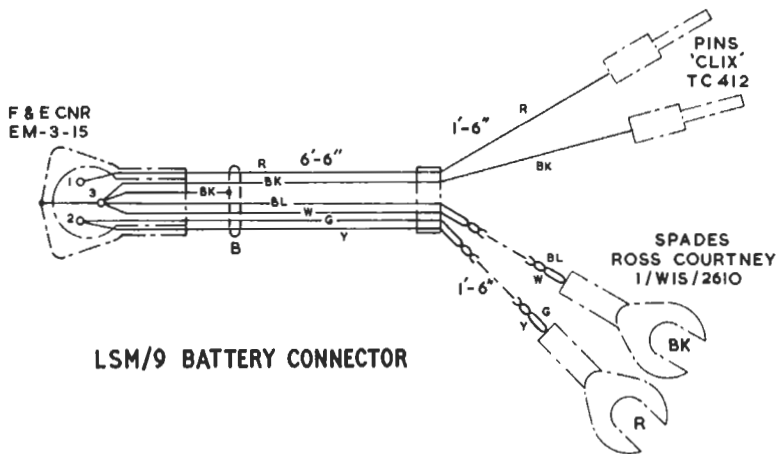

LSM/9 BATTERY CONNECTOR

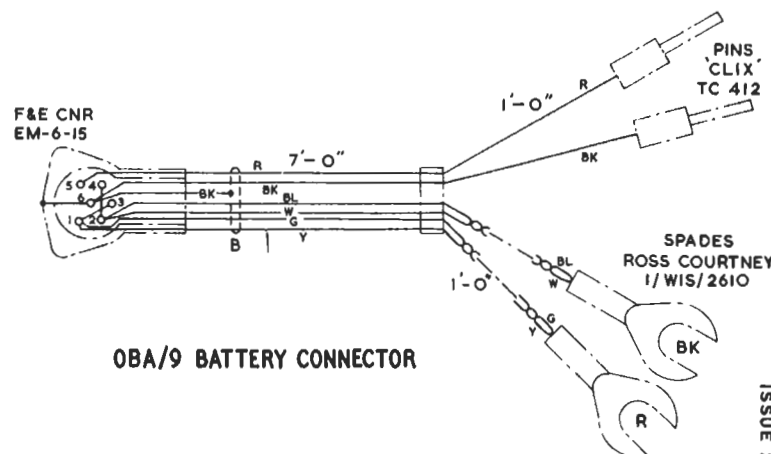

OBA/9 BATTERY CONNECTOR

OBA/9 EQUIPMENT : CONNECTOR CABLES

NOTE:- SHROUD OF EACH F & E CNR HAS INTERNAL EARTH TAG FITTED