

## SECTION 13

## AMPLIFIER OBA/8

**General Description**

The OBA/8 amplifier is designed as a unit incorporating a control potentiometer, peak programme meter, and all the necessary line-switching facilities. It can be used with either BBC-Marconi ribbon or S.T. & C. moving-coil microphones for sending programme to line at a maximum volume of +4 dB. An attenuator is provided in the output circuit for adjusting the volume sent to line to either +4 dB, zero or -4 dB. By a special arrangement of the circuit the programme volume indicated by the programme meter is a measure of the approximate power (instead of the voltage) sent to line, and consequently no adjustment is necessary in respect

- 2 mains units, MU/3, each in a separate carrying case
- 1 microphone mixer (4-channel), MX/18, in a carrying case which also accommodates the communication units and their connecting cable
- 1 communication unit, CMU/6
- 1 communication unit, CMU/7
- 1 loudspeaker unit, LSU/1, constructed in the form of a folding baffle and incorporating an amplifier, LSM/4, mains unit, MU/7, and a loudspeaker, and also housing the associated mains lead
- 1 set of inter-unit connectors, cords, mains and battery connectors, five-way mains turret

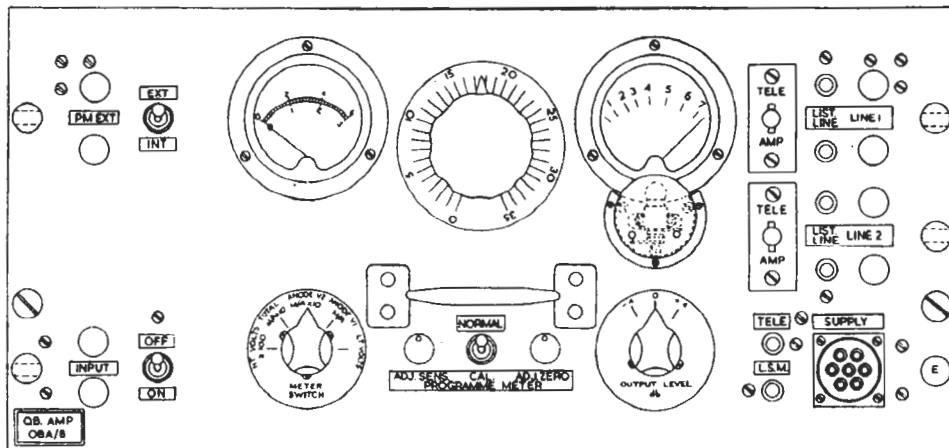

Fig. 13.1. Face Panel OBA/8

of the impedance of the line into which the amplifier works. The amplifier is arranged to operate either from a.c. mains or from batteries.

The OBA/8 amplifier, in conjunction with its associated apparatus, provides a complete set of equipment for an O.B. point. Each set of apparatus comprises the following:—

- 2 or 4 microphones, as required, in a carrying case
- 2 amplifiers, OBA/8, each in a separate carrying case

connector, including spares, and a set of spare valves, in a common carrying case

- 2 portable telephone sets with batteries

The general arrangement of the apparatus, showing the normal connections, is given in Fig. 44. The earth connection is made to the amplifier as shown, and is extended to the other units via the cable screens, special spring earthing clips being provided on each unit for making the connection. As an additional precaution, the LSU/1 and MU/3 are fitted with earth terminals

## INSTRUCTION S3

### Section 13

which must be connected to a direct earth. The plugs and sockets used for making the connections to the various units are all keyed to prevent improper connection, but for convenience in aligning the plugs before insertion, dots are inscribed on the plugs and socket mountings in positions which correspond.

Each O.B. amplifier consumes approximately 25 mA at 250 V and 3.5 A at 4 V, and each loud-speaker amplifier approximately 30 mA at 300 V and 2 A at 4 V. The supplies, as stated, are normally obtained from the respective mains units but batteries must be provided for emergency use in the event of failure of the mains. No provision is made for connecting batteries on the loud-speaker unit but battery terminals are provided on the mains units MU/3 associated with the O.B. amplifiers. Separate batteries are required for each O.B. amplifier. For the l.t. supply, 6-V, 40-Ah batteries must be provided, a suitable resistance being included in the mains unit to drop the voltage to 4V at the valve terminals. For the h.t., dry batteries of suitable voltage and capacity suffice.

Where a.c. mains are not available the amplifiers will be battery operated and the battery equipment mentioned above must be duplicated.

The arrangement of the front panel of the amplifier is shown in Fig.13.1 and the circuit in Fig. 45.

Referring to the circuit drawing, the amplifier itself comprises two resistance-capacitance coupled high-slope pentode stages, using AC/SP3 valves, with a high-ratio screened input transformer and choke-capacitance transformer-coupled output circuit.

Due to the action of the leakage inductance of the transformer, in conjunction with the grid-to-cathode capacitance of the valve, the capacitance between the wiring, and the capacitor C1 connected across the primary, the input circuit of the valve V1 constitutes a low-pass filter cutting off at approximately 10,000 c/s. On the other hand, the output circuit of the valve V2 constitutes a high-pass filter, the choke R/1A virtually shunting the load as regards the lower frequencies. Its effect is, however, restricted to frequencies below 30 c/s by the resistor R15 which can be considered as shunting the choke. (C10 is merely a blocking capacitor to prevent the d.c. component from reaching the output circuit.) The complete amplifier thus acts as a band-pass filter with a pass band extending from 30 to 10,000 c/s.

A rising characteristic above 2,000 c/s, required

for ribbon microphones, is provided by connecting the choke S/1A in series with the anode resistance of the valve V1 so as to increase the gain of this stage at the higher frequencies. The response at the lower frequencies is reduced by suitably adjusting the values of the inter-stage and output coupling capacitors.

It will be seen from Fig. 45 that frequency correction can be removed by inserting straps at the points AA, BB and CC. The use of frequency correction is dependent upon conditions obtaining in other parts of the programme chain and the omission or inclusion of the straps is subject to specific instructions governing local requirements.

With a turns ratio of 1/31.6 in the input transformer and a step-up impedance ratio, therefore, of 1/1,000, and since the secondary is loaded with 300,000 ohms, the input impedance of the amplifier is 300 ohms. The primary of the output transformer is loaded by R15 and R16 parallel, equivalent to 33,000 ohms, and since the output transformer has a turns ratio of 1/20 the output impedance is approximately 75 ohms.

Gain control is provided by the potentiometers R18 and R19, which consist of two ganged elements operated by a single control. The potentiometer R18 operates by the progressive application of negative feedback to the valve V1, reducing the gain in 8 steps of 2 dB (total 16-dB) and operating over the first 9 studs (Nos. 35-27) of the switch. The potentiometer R19 in the grid circuit of the output stage operates over the remaining studs (Nos. 26-0), providing an attenuation of 2 dB per stud over the greater part of the range and then larger steps to give a complete fade out. Studs 35 to 27 of R19 are connected together so that this potentiometer remains at full gain until stud 26 is reached, while stud 27 and all the remaining studs of R18 are connected together so that this potentiometer remains on minimum below stud 27.

Negative feedback consists of providing coupling between the anode and grid circuits of a resistance-coupled valve via a resistance in the cathode lead so as to apply to the grid a portion of the output which will be 180° out of phase with the signal voltages applied to the grid. The effect of negative feedback, as applied to a high-slope pentode valve, though reducing the effective gain, enables the valve to handle without distortion a signal that would normally cause serious overloading. In the case of V1 the arrangement is such that the full gain of the pentode is available

if the applied signal is very weak, but that as the strength of the input signal increases, the effective "grid-base" of the valve is extended at the same time as the gain is reduced, to enable the valve to handle the increased voltage swing applied to its grid without overloading.

The negative feedback is provided by the resistors R5 and R6 connected between cathode and - h.t., R5 also providing grid bias to the valve. The potentiometer R18 is connected across R5 and R6 in series with C3, and its slider is returned to the grid via the coupling capacitor C2; to prevent frequency discrimination in the feedback voltage, R7 is large compared with the reactance of C2 over the pass band of the amplifier. When the slider is at the earthy end of R18 (stud 27) the whole of the negative feedback potential is applied to the grid and when it is at the other end of R18 (stud 35) the cathode is short-circuited to the grid, as regards a.c., via C2.

Provision is thus made for applying attenuation in 24 steps of 2 dB between studs 35 and 11 and then in 10 steps of 3 dB between studs 11 and 1 with a complete fade-out on stud 0. Under normal working conditions the amplifier must not be operated with a gain less than that given by stud 10.

Negative feedback amounting to 6 dB is also applied to V2 to enable this valve to handle the output delivered to line without overloading, and is obtained from the resistor R13 which also provides the negative bias to the valve. The correction circuit C8, R14 shunting this resistor is introduced to modify the frequency characteristic of the feedback to compensate for certain small losses in the neighbourhood of 8,000 c/s.

Decoupling for the screen supply to V2 is provided by C9 and for the h.t. supply and screen supply to V1 by C7 and C4, respectively.

Meter shunts are included which, in conjunction with the metering switch and meter provided on the panel, enable the h.t. voltage, the total h.t. current and the individual anode currents taken by V1 and V2 to be read. When batteries are being used the l.t. voltage also can be read.

The anode current taken by valve V1 is 1 mA  $\pm$  0.2 and that taken by valve V2 is 12.5 mA  $\pm$  2.0.

The outers of the loudspeaker jack to which the input of the LSM/4 can be plugged are connected across R17, which is permanently included in the anode return circuit of V2. In the original circuit, R17 was connected across the inners of the jack and was replaced by the 2,000-ohm

input of the LSM/4 when this was plugged up.

The revised circuit makes the anode circuit of V2 independent of the jack contacts and the potential for feeding the input of the PPM circuit is obtained from an additional series resistor R41. With this rearranged circuit the output voltage of the amplifier remains sensibly constant, whether the LSM/4 is plugged up or not.

Where the LSM/4 input leads are very long, a capacitance effect may be introduced, which will affect the high-frequency response of the PPM. If, therefore, the PPM be used for frequency tests, the LSM/4 should be unplugged.

The maximum voltage gain at 1,000 c/s, working into a 600-ohm load, is 91 dB. The gain at 9,000 c/s is approximately + 4 dB, and that at 50 c/s, - 5 dB, with respect to that at 1,000 c/s when the correction circuit for ribbon microphones is in use.

The output is connected via an attenuator controlled by a three-position switch. Position 1 with the attenuator out of circuit corresponds to the switch position designated +4, position 2 with attenuation of 4 dB in circuit corresponds to the switch position designated 0 and position 3 with the full attenuation of 8 dB in circuit, to the switch position designated - 4.

The attenuator output is wired to one pair of make contacts of both the line change-over keys and the outers of the telephone jack to the other pair of make contacts in each case. Terminals and line and listen jacks, wired in parallel in each case, are provided for two lines which are wired each to the travellers of one of the change-over keys. By suitable operation of the keys, therefore, either line can be connected either to the amplifier output or to the telephone set.

### The Peak Programme Meter

The peak programme meter is incorporated in the amplifier and its circuit is shown in Fig. 45.

The signal is applied via an input transformer and is then rectified by a full-wave rectifier, the output of which charges up C13, connected across the grid circuit of a variable- $\mu$  pentode valve, with the programme meter connected in its anode circuit. The meter is of the right-hand zero, quick-acting type, but is calibrated like a normal programme meter from left to right, 1 to 7. By suitable adjustment of the screen and grid-bias voltages the valve is arranged to operate over the particular part of the curved portion of its characteristic which gives the required logarithmic law, and to deflect the meter to zero when the standing

feed has its correct value. The output of the rectifier is applied to the grid in a negative sense so that the stronger the signal the more negative the grid and the smaller the feed.

The time constant of the circuit is such that if a transient pulse is applied the voltage attained by the capacitor will rise to within 2 dB of the value of the applied voltage within 4 milliseconds. The indications of the programme meter will, therefore, correspond very nearly to the peak levels actually present in the programme. The return time from full deflection to 1 is of the order of 3 seconds.

A switch and a pair of terminals are provided to enable an extension programme meter to be connected in series with that included in the amplifier unit. A neon stabiliser is fitted for maintaining the screen voltage applied to the variable- $\mu$  valve.

The impedance of the lines with which the O.B. amplifier will be used may vary between 75 and 600 ohms. Consequently if the programme meter amplifier input were connected across the amplifier output so as to regulate the voltage sent to line, the power actually sent to line for a given programme meter reading might vary for different lines by as much as 9 dB. This is a greater variation than, from considerations of cross talk and overloading of repeaters, Lines Department is prepared to allow. In this equipment the programme meter input is connected across a 2,000-ohm resistance included in the amplifier output circuit in series with the output loading network. This network consists effectively of the load reflected into the primary of transformer T2, shunted by 30,000 ohms resistance connected across the primary. With this arrangement for a particular reading of the programme meter, the maximum variation in the level sent to line (measured in terms of power and ignoring the voltage) will always lie, in practical cases, as is shown below, between limited of  $\pm 2$  dB.

If we denote the value of the line impedance by  $75x$  ohms,  $x$  will have a value lying between say 1.0 and 8.0 in all cases met with in practice (since, as stated above, the line impedance can vary between values of 75 and 600 ohms). If  $n$  is the turns ratio of the output transformer, the line impedance referred to its primary circuit can be represented by a resistance equal to  $n^2 \cdot 75x$  ohms, or  $30,000x$  ohms, connected in parallel

with the (equivalent) 30,000-ohm resistance already connected across the primary of the transformer. The complete output circuit of the amplifier may therefore be represented as shown in Fig. 13.2.

If  $i$  is the total current, the current in the line will be proportional to

$$\frac{30,000}{30,000 + 30,000x} \cdot i$$

i.e., to

$$\frac{1}{1+x} \cdot i$$

and the power ( $I^2R$ ) in the line will be proportional to

$$\frac{1}{(1+x)^2} \cdot i^2 \cdot 30,000x$$

i.e., to

$$\frac{x}{(1+x)^2} \cdot 30,000i^2$$

whence if  $i$  is maintained constant the power in the line will vary in proportion to

$$\frac{x}{(1+x)^2}$$

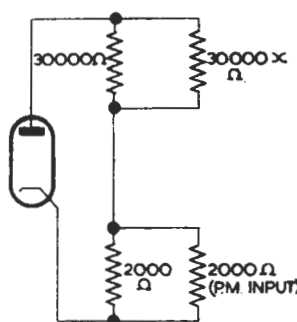

Fig. 13.2. Output Circuit (Theoretical)

Now, as stated,  $x$  can vary between 8.0 and 1.0, i.e., in the ratio of 8:1 or 9 dB; but  $\frac{x}{(1+x)^2}$  will only vary between 0.25 and 0.10, i.e., in the ratio of 2.5 or 4 dB.

The programme meter is adjusted to read 4 when the output-level switch is set at 0 and the amplifier is feeding a voltage level of 0 dB into a 600-ohm load. (Formerly, a switch setting of +4 and a load of 240 ohms were specified.)

**Calibration at O.B. Point.** This should be carried out only after the equipment has been switched on for about 10 minutes.

- (1) Adjust the programme meter to read zero by means of the control marked *Adj. Zero*.
- (2) Unplug the LSM/4, and throw the calibration switch to the *Cal.* position.
- (3) Bring the programme meter reading to 4 by means of the *Adj. Sens.* control.
- (4) Restore the calibration switch to *Normal*.

The programme should now be controlled so that during loud passages the meter deflects to 6 on peaks. Under these conditions a power volume of approximately 0 dB is delivered to line when the output-level switch is in the 0 position.

**Complete Calibration.** If the neon tube or AC/VP1 valve has to be replaced, an accurate calibration cannot be made at the O.B. point.

When a complete calibration is to be carried out, a tapped transformer or 'Variac' should first be inserted between the mains-supply socket and the mains input to the MU/3. The equipment should be switched on with the mains-unit input voltage adjusted to the nominal value of the supply, e.g., 240 volts, the mains voltage tap-selector switch on the MU/3 being also set to this value. Allow 10 minutes for warming up, then proceed as follows:—

- (1) Set the amplifier gain control on 26 stud and terminate the amplifier in 600 ohms.
- (2) Rotate the *Zero Balance* control fully clockwise. Restore the meter reading to zero using the *Adj. Zero* control.
- (3) Apply 1,000-c/s tone at a level of approximately -70 dB to the amplifier input and adjust the level of the tone so that zero voltage level is obtained at the amplifier output (measured with the high-impedance amplifier detector connected across the 600-ohm terminating resistance) the output-level switch being in the position marked 0.
- (4) Bring the meter reading to 4 by means of the *Adj. Sens.* control.
- (5) Check whether the programme meter needle follows the scale divisions over the range from 6 to 2 when the input level is altered in 4-dB steps, two above and two below the level which causes the meter to read 4.
- (6) If the calibration is incorrect:
  - (i) Switch off the tone.

- (ii) To open the scale, i.e., if in (5) the meter reads above 2 and below 6, adjust the programme meter to read between 0 and 1 by means of the *Adj. Law* control.

To close the scale, i.e., if in (5) the meter reads below 2 and above 6, set it to read below zero by means of the *Adj. Law* control.

- (iii) Restore zero, using *Adj. Zero* control.
- (iv) Repeat (5) and (6) as necessary.
- (7) Set the *Zero Balance* control to its mid position, and restore the meter reading to zero by means of the *Adjust Law* control.
- (8) Reduce the mains-unit input to 200 volts. If the meter reading rises, the *Zero Balance* control has not been rotated far enough. If the reading falls, the control has been turned too far.
- (9) Restore the mains-unit voltage to normal, rotate the *Zero Balance* control a small amount in the direction as indicated in (8) above, and re-set the meter zero by means of the *Adjust Law* control.
- (10) Reduce the mains-unit input volts once again to 200, and proceed as above, until varying the voltage between 240 and 200 produces no change in the zero.

At each stage, allow 20 seconds for changes in valve-heater voltage to take effect.

The programme meter amplifier itself will now be fully calibrated as regards both its law and its sensitivity. It therefore only remains to adjust the 50-c/s supply used for calibrating it at an O.B. point and obtained from the heater supply. This is carried out as follows:—

- (11) Switch off the tone and throw the programme meter calibration switch to the *Cal.* position. Then, having first ascertained that the correct mains tapping on the mains supply unit, MU/3, is being used, adjust the programme meter to read 4 by means of the *Adjust P.M. Cal. Input* control.

### Mains Unit MU/3

This is a conventional circuit for obtaining an h.t. supply at 250 V d.c., 25 mA, and an l.t. supply at 4 V, 50 c/s, 3.5 A, from 50-c/s a.c. mains at any voltage between 200 and 250. An indirectly-heated double-diode valve UU/4 is used in the h.t. supply circuit.

**INSTRUCTION S3**  
**Section 13**

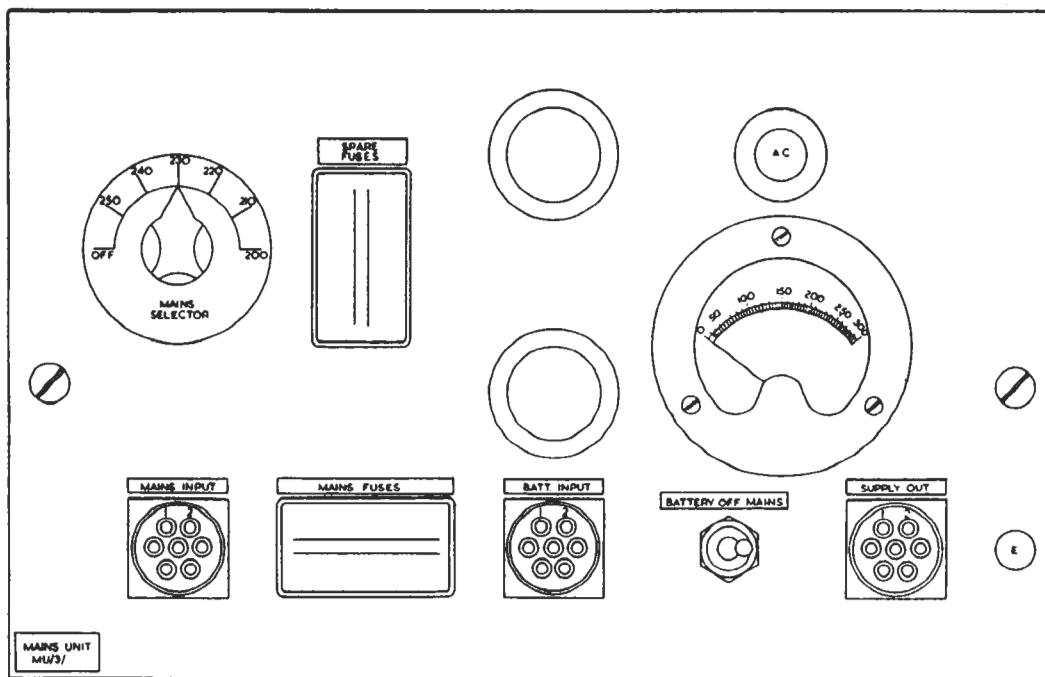

Fig. 13.3. Face Panel MU/3 and MU/3A

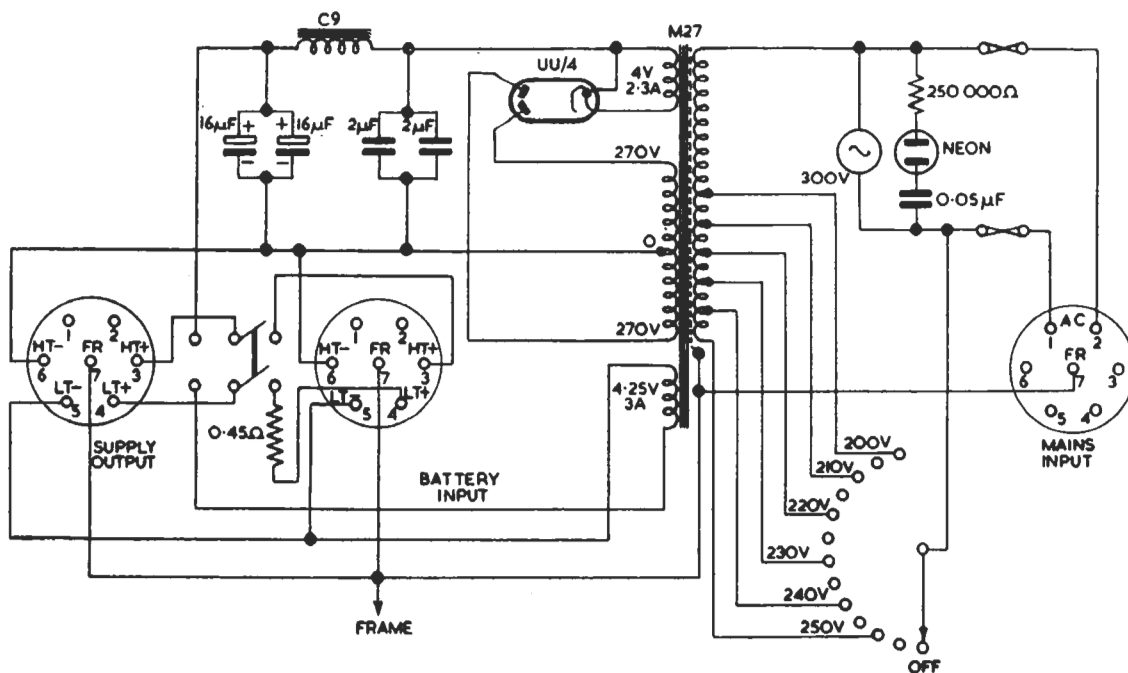

Fig. 13.4. Circuit of Mains Unit MU/3

A voltmeter is provided for reading the mains voltage and a switch for selecting the appropriate primary tapping. The selector switch has an 'off' position and is used for the mains switching on the unit. A neon indicator is connected in series with a capacitor across the mains terminals and therefore glows as soon as the unit is plugged up to the mains. The presence of the capacitor ensures that the lamp will not light if connection is made to d.c. mains, and thus serves as a warning against moving the selector switch from the "off"

the end of the resistor and the off stop, a high-resistance or static leak, is provided in order to preserve continuity and so prevent any difference of potential developing between the microphone line and the output circuit which might give rise to clicks when the microphone is faded up.

The arrangement of the front panel is shown in Fig. 13.5, and the circuit in Fig. 13.6. At the back of the carrying case, compartments are provided for the storage of the communication units and their connecting cable.

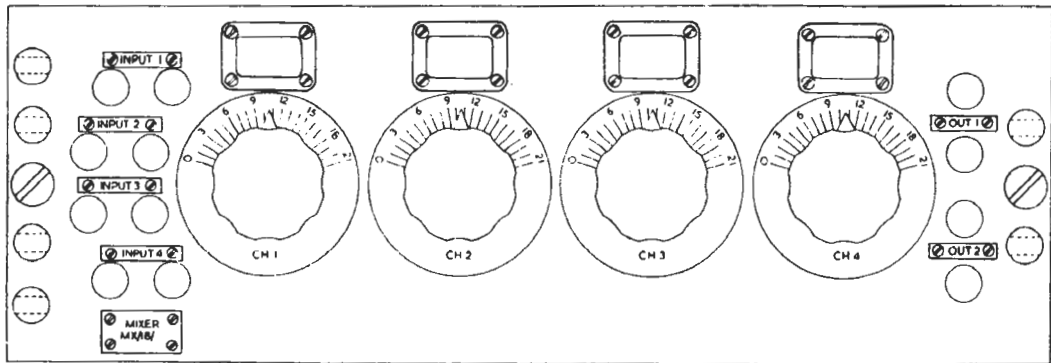

Fig. 13.5. Face Panel MX/18

position which in these circumstances would result in the fuses being blown.

The stand-by battery connections are also made to the mains unit and a change-over switch is provided for connecting the output sockets either to the supplies obtained from the mains or to those obtained from the batteries. The 0.45-ohm resistance inserted in the positive battery lead is provided for dropping the voltage so as to obtain 4 V at the valve terminals of the amplifier. The main fuses, one in each leg, are carried in a plug-in type holder on the front panel, and a spare holder equipped with fuses is provided in a spare holder ready for change-over in the event of failure.

The mains unit MU/3A is similar to MU/3, but the mains transformer gives an l.t. supply of 4 V, 5 A and is designated M27c. Most OBA/8 amplifiers have MU/3A mains units.

#### Mixer Unit MX/18

This is a four-channel balanced series fade unit. On one leg of each potentiometer between

#### Loudspeaker Unit LSU/1

The loudspeaker unit LSU/1 comprises an amplifier LSM/4, with the associated mains unit MU/7, and a loudspeaker. A block schematic of the circuit arrangement is given in Fig. 13.7. The unit is constructed as a wooden box with the loudspeaker grille in the front panel and with the back hinged about the middle of the top so that it can be raised to align with the front panel and form a large baffle. For transport purposes the loudspeaker grille is covered with an aluminium plate. The amplifier and mains units are inserted from the back and holes are provided in the front panel to give access to the volume control and the input jack on the front panel of the amplifier unit, and to enable the lamp provided on the front of the mains unit to be seen.

#### Loudspeaker Amplifier LSM/4 (Fig. 13.8)

For the amplifier LSM/4, a paraphase push-pull circuit is used employing two AC/SP3 valves with negative feedback and giving a power output

**INSTRUCTION S3**  
**Section 13**

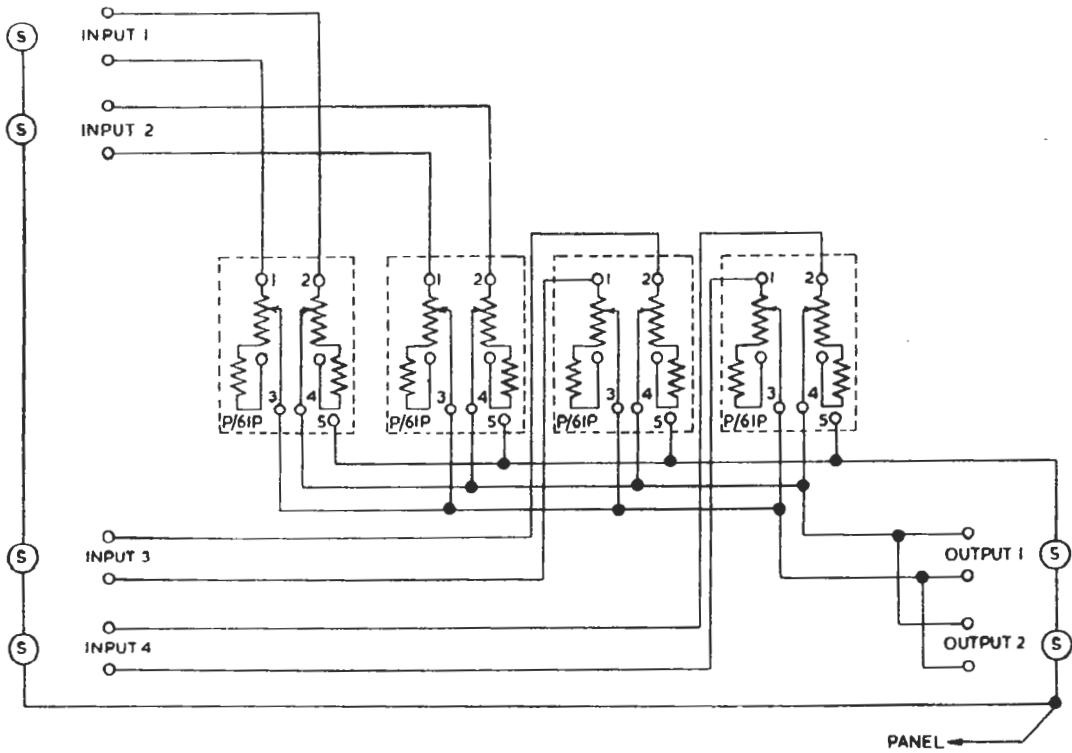

Fig. 13.6. Circuit MX/18



Fig. 13.7. LSU/1 Block Schematic



of 1.5 watts. The reason for adopting this circuit was to make possible a design of loudspeaker amplifier satisfying exacting requirements as regards gain, power output, frequency characteristic and freedom from harmonic distortion, using the same type of valves as those used in the O.B. amplifier. It should be noted, however, that an AC/SP3A is used in the first stage of the OBA/8 and an AC/SP3B in the second stage. The LSM/4

to a steady tone at a power level of + 4 dB to line is approximately 0.7 V giving 8.5 V across the secondary of the transformer. But the input circuit of the valve to which this input is applied is connected to earth via the output circuit in such a way that the voltage developed across the load is fed back to the input in inverse phase.

The loudspeaker is a Wharfedale model of the permanent-magnet type with an impedance of

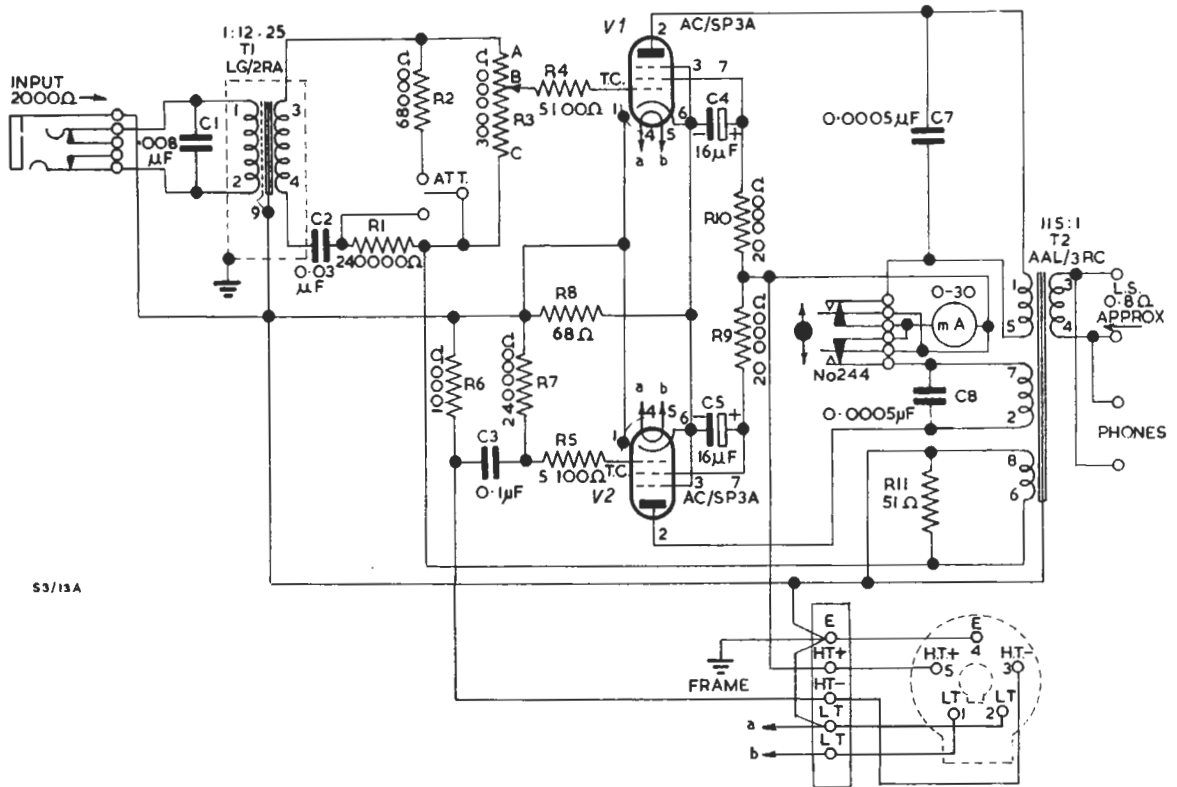

Fig. 13.8. Circuit LSM/4

valves, which are AC/SP3A's, may be used in either stage of the OBA/8.

The input transformer has a turns ratio of 1 : 12.25 and, since the secondary is loaded with 300,000 ohms, the input impedance is 2,000 ohms. The leakage inductance in conjunction with the primary and secondary capacitances forms a low-pass filter cutting off at approximately 10,000 c/s. The input circuit is connected in parallel with that of the programme meter amplifier and the level is therefore **independent of the line** impedance and sending level. The input voltage corresponding

to 1.5 watts is therefore 1.73. The output transformer has a turns ratio of 115 : 1 so that the load impedance referred to the primary side of the transformer is about 25,000 ohms, across which is developed an a.c. voltage of approximately 200 giving an a.c. current of about 7.5 mA.

The voltage actually applied to the grid of the valve is the difference between the applied input signal and the feedback voltage and, since the valve has a mutual conductance of approximately 7.5 mA per volt, the net input voltage required to



monitoring but is provided to facilitate checking line noise. A 15-dB attenuator comprising the resistors R1 and R2 is connected in the input circuit and is controlled by a switch designated *Att. In—Att. Out* mounted on the side of the amplifier unit. For normal monitoring the attenuator should be in circuit.

It should be observed that the arrangement adopted in the O.B. amplifier output circuit for supplying the loudspeaker and programme meter amplifier inputs (discussed on pages 13.3 and 13.4) besides ensuring that the power to line will be practically independent of the line impedance

The rectifier valve is an indirectly heated double-diode, Type UU/4 or UU/5 operating as a full-wave rectifier.

The primary of the mains transformer is provided with tapings for mains of various voltages. In use, the selector switch, which is available at the back of the unit when the baffle is raised, should be set to the corresponding tapping to that used for the O.B. amplifier. The switch has an "off" position and is used for the mains switching on the unit. A lamp supplied from the l.t. circuit is provided on the front panel to indicate when the amplifier is switched on.

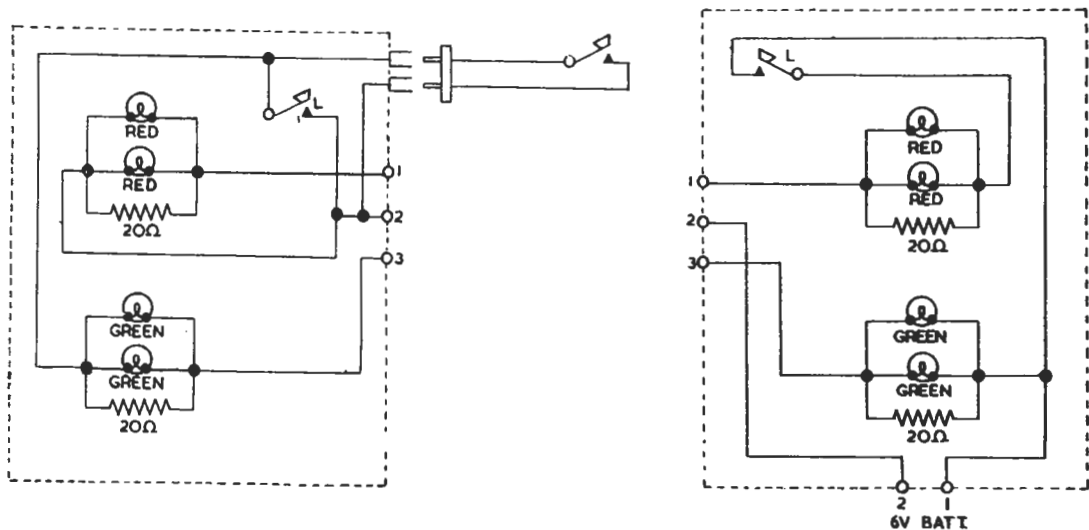

Fig. 13.10. Circuits of CMU/6 and CMU/7

also ensures that the quality in the loudspeaker will equally be unaffected by variations of the line impedance in any particular case over the frequency range reproduced.

**Mains Unit MU/7 (Fig.13.9)**

The mains unit MU/7 is of conventional design and provides an h.t. supply at 300 V d.c., 30 mA and an l.t. supply at 4V, 50 c/s, 2A, from 50 c/s a.c. mains at any voltage between 200 and 250.

**Communication Units CMU/6 and CMU/7**

These units are provided to enable cue-light signals to be exchanged between the mixing point and the amplifier. The unit is equipped with two red and two green lights and a push-button switch with provision for locking. The CMU/7 unit which is used at the mixing point is similar in construction except that the 6-V battery terminals are omitted and provision is made for plugging into the unit the leads of a pendant type

## INSTRUCTION S3

### Section 13

switch as an alternative to the push-button switch to enable the unit to be operated from a distance.

The arrangement of the circuits of the two units is shown in Fig. 13.10. When the correspondingly numbered terminals of the two units are interconnected it will be seen that the red lamps of both units can be connected in series with the 6-V battery by closing the contact of the press-switch of the CMU/6 unit, while the green lamps of both units can be connected in series with the battery by operating the switch of the CMU/7 unit. Thus the red lights are used for signalling from the amplifier to the mixer and the green lights for signalling in the reverse direction. The lamps are duplicated in each case and continuity in the event of the failure of both lamps of a kind in one of the units is secured by shunting them with a resistance.

#### Valve Data

Stage	Valve	Anode Potent.	Anode Current	Screen Potent.	Screen Current	Fil. Potent.	Fil. Current
V1	AC/SP3A	92V	1.05mA	100V	0.3mA	4.0V	1.0A
V2	AC/SP3B	210V	12.5mA	150V	5.0mA	4.0V	1.0A
V3	D41					4.0V	0.3A
V4	AC/VPI					4.0V	0.65A

Total Feed, 24 mA.

L.T. supply 4 V, a.c., 3 A.  
or 6 V, d.c.

H.T. supply, 250 V.

} Mains, or  
Battery through  
MU/3

#### General Data

##### Programme Meter Lamp

Osram Flashlight Lamp, focusing type, 6.5 V  
0.3 A, 12-mm round bulb.

##### Neon Stabiliser

BBC Type S1.

##### Potentiometers

Adjust Sensitivity : Morganite Stackpole LHAP  
50250, 5,000Ω.

Adjust Zero : Morganite Stackpole MNAP  
50350, 50,000Ω.

Adjust Law : Morganite Stackpole LHAR  
10250, 1,000Ω.

Zero Balance : Morganite Stackpole LHAP  
50250, 5,000Ω.

Adjust P.M. Cal.  
Input : Morganite Stackpole LHAR  
10250, 1,000Ω.

Gain Control : Painton P/63P.

#### Switches

Meter Switch : Yaxley Type A, 2-bank, 9-position

Output Level : Yaxley Type B12, 3-pole, 3-position.

#### Impedances

Normal Source : 300Ω (balanced).

Normal Input : 300Ω ± 10%.

Output : 75Ω ± 10%.

Normal Output

Load : Line (100Ω - 2,000Ω)  
(balanced).

#### Normal Working Input Volume

Ribbon - 80 to - 50 dB M.C. - 70 to - 40 dB.

#### Normal Working Output Volume

0.5 V into 75-Ω load.

#### Test Input Level. (Max. Gain.)

- 90 dB.

#### Normal Voltage Gain

+ 86 dB when loaded with 75 Ω.

#### Feedback Details

P/63P 1st 8 steps 2 dB each. Cathode f.b. in stage 2 to give straight response, i.e., compensating for various circuit treble losses.

#### Total Percentage Harmonic Content

Normal working 8 dB above normal  
input and output output and input  
levels. levels.  
Frequency 50 c/s. < 1% total. < 1% total.

#### Noise Level with Maximum Gain

- 36 dB (measured by VV).

- 42 dB (measured with 100 c/s l.p. filter).

This drawing is the property of the British Broadcasting Corporation and may not be reproduced or disclosed to a third party in any form without the written permission of the Corporation.

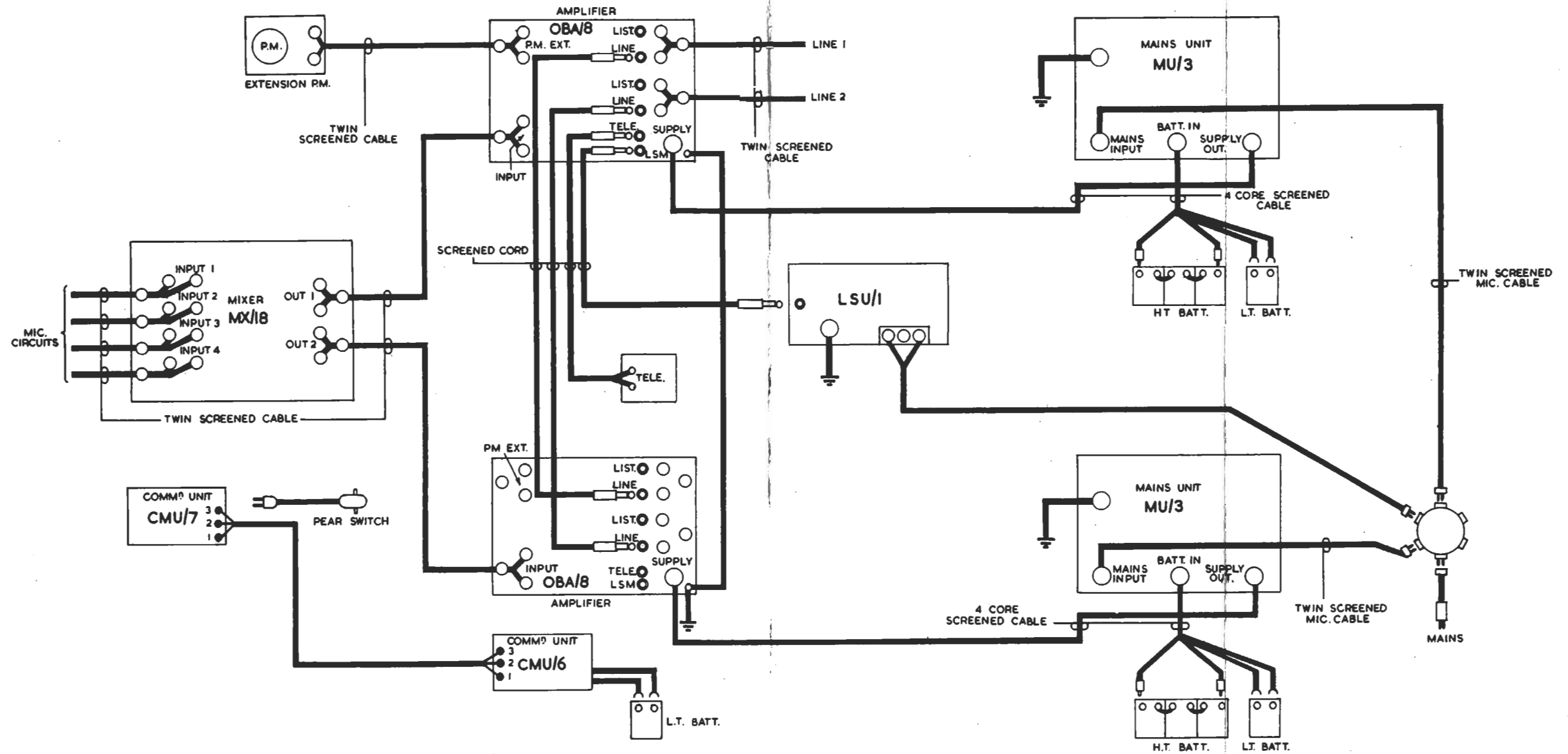

GENERAL ARRANGEMENT. OBA/8 & ASSOCIATED EQUIPMENT

