

MIXER MX1/9

See also AM1/4

Introduction

Mixer MX1/9 was designed for use as part of transportable stereo studio equipment EP5/11, in which it is the right-hand one of three units of the main console. A general view of the MX1/9 is given in Fig. 1 and a circuit diagram in Fig. 2.

Horizontal Panel

General

A horizontal panel carries controls for 10 mono channels, *Cubicle L.S. Volume* and *Balance* controls, and *Cubicle L.S. Selector* and *A/B* switches and

L.S. Dim/Phase-reverse key, together with a 'White' key (Fig. 1), a *Line/Studio Talkback* key, two green and one red cue-light keys and a selector switch for an auxiliary P.P.M. on the MX1/8 which is the left-hand unit of the EP5/11 console.

Mono Channel Controls

The 10 mono channel faders, Type PB/38Q/4S, are mounted in two groups of five. Their associated pan-pots are mounted in two corresponding groups on the central control unit UN3/17 of the EP5/11 console.

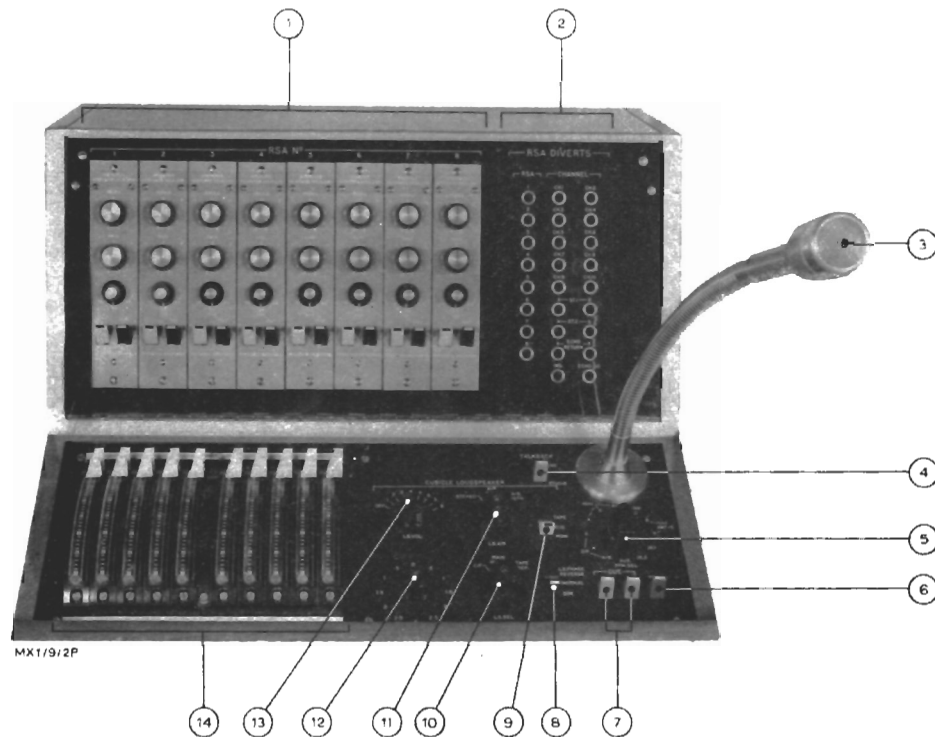

Fig. 1. MX1/9 Control Panels

- | | |
|-------------------------------------|------------------------------|
| 1. R.S.A. amplifiers AM1/4 | 8. L.S. Dim/Ph. Rev. key |
| 2. R.S.A. divert jackfield | 9. 'White' key |
| 3. Desk talkback microphone | 10. Cubicle L.S. selector |
| 4. Line/Studio talkback key | 11. Cubicle L.S. A/B switch |
| 5. Aux. P.P.M. selector | 12. Cubicle L.S. balance |
| 6. Red light key | 13. Cubicle L.S. Volume |
| 7. Cue 1 and cue 2 green light keys | 14. Mono channel faders 1—10 |

Cubicle L.S. Controls

These controls are on the right of the channel faders. The *Cubicle L.S. Volume* control has an *Off* position. On switching from *Stereo* to the (*A + B*) condition with the *A/B* switch, 6-dB pads are introduced so that there is no apparent change in loudness between the two conditions.

When the *Talkback* key is operated, the cubicle loudspeaker is dimmed, the reduction in level being adjustable by a preset *T/B L.S. Dim* control at the rear of the unit. This adjustment does not affect the action of the normal *Dim* key.

Response Selection Amplifiers

Eight response selection amplifiers AM1/4 are mounted on a hinged panel, together with a 'divert' jackfield which allows an R.S.A. to be introduced into any channel by the insertion of a single jack-plug. Each R.S.A. is connected in an unbalanced circuit with the input on the plug tip and the output on the ring, the sleeve circuit being common. This unbalance is permissible because the flat gain of the amplifier is zero, and even at maximum settings there is not more than 16 dB difference between input and output. Channels are normalised via the jack inners except when R.S.A.s are required.

Interconnection Facilities

General

Interconnections with other units of the EP5/11 are made at the rear of the unit, the plugging system being indicated on an engraved panel. The main circuits are brought out on eight 26-way

Tuchel sockets, which engage with plugs on UN1/107 10-pair cables. Further circuits are carried on an 8-pole fixed plug engaging with a socket on an 8-way cable.

There is also a standard microphone plug, paralleled across the 600-ohm talkback microphone, enabling its output to be taken to other units, such as the O.B. Bouyer talkback system.

Auxiliary P.P.M.

Four *Auxiliary P.P.M.* jacks allow external apparatus to be monitored via the *Auxiliary P.P.M. Selector* switch positions *JK1* and *JK2* and the ME12/5 amplifier feeding this P.P.M., which has a high input impedance and is set at 20 dB gain.

Two of the jacks, labelled *-20 dB Hi Z*, give direct access to the selector switch. The two others, labelled *0 dB 600 Ω*, give access via 600/600-ohm 20-dB pads.

Cubicle Loudspeakers

The cubicle loudspeakers can be plugged to the appropriate *A* and *B* sockets or associated jacks. The *A* or left-hand loudspeaker socket is on the left of the unit, *as viewed from the rear*.

Since various types of loudspeakers and their associated amplifiers, having various input impedances, may be encountered under O.B. conditions, the loudspeaker circuits have been treated as 600-ohm circuits, the loudspeaker sockets being loaded with 600-ohm resistors. The feed to the loudspeakers is balanced by transformers T43 and T44 which follow the contacts of the talkback dim relay LSC.

JL(X) 8/69

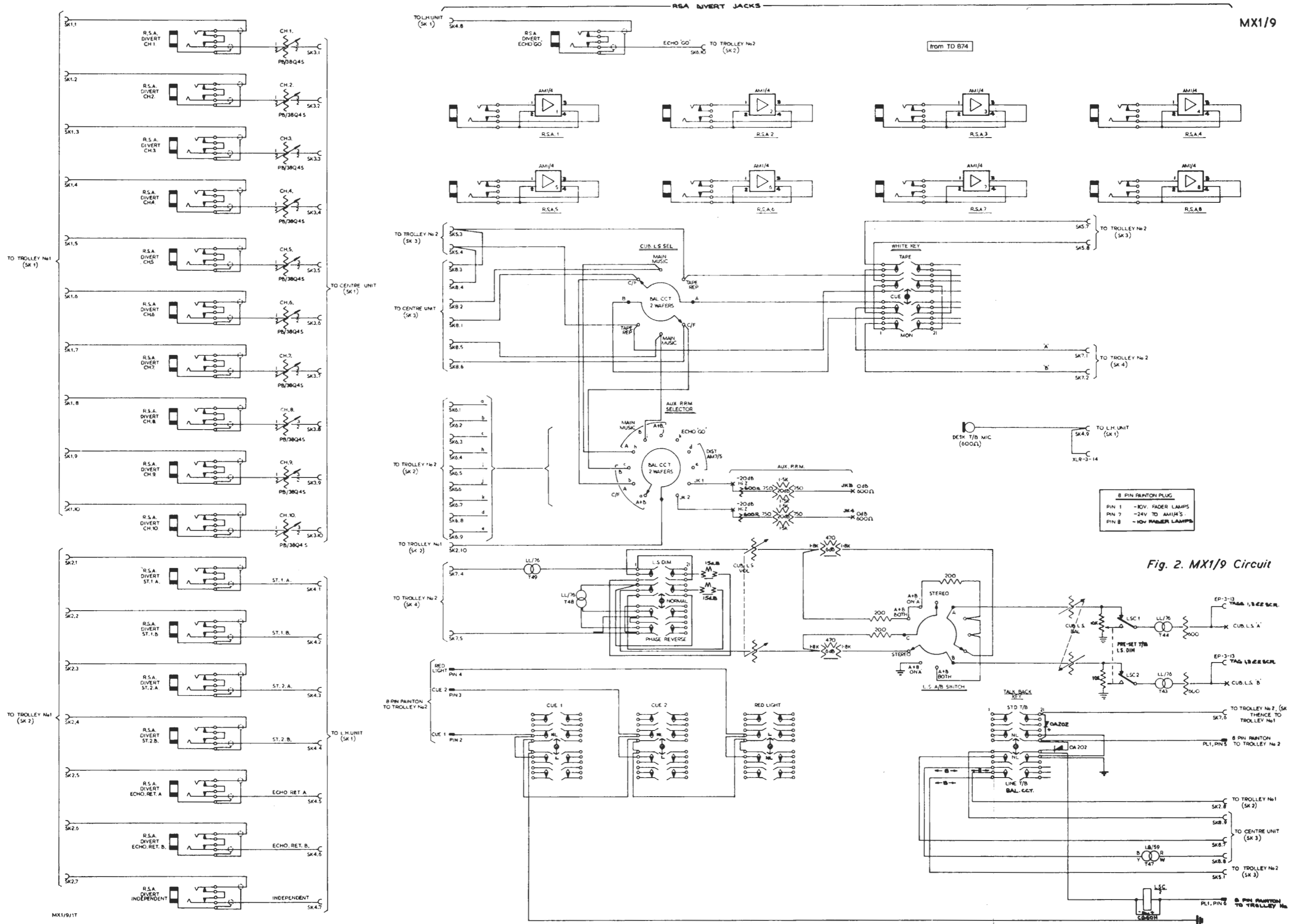

8 PIN PANTON PLUG
 PIN 1 -10V. FADER LAMPS
 PIN 7 -24V TO AM1/4'S.
 PIN 8 -10V FADER LAMPS

Fig. 2. MX1/9 Circuit