

OSCILLATORS OS2/13 AND OS2/14

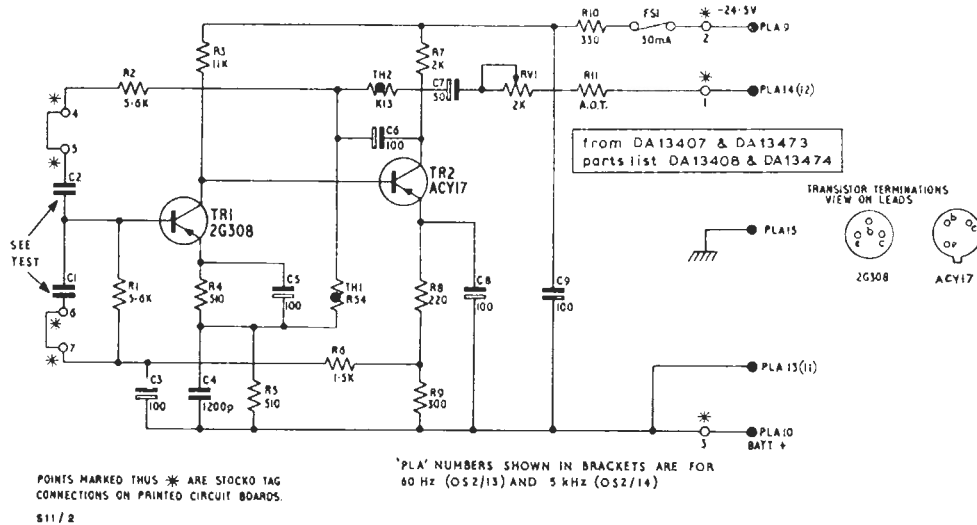

Fig. 1. Oscillators OS2/13 and OS2/14: Circuit of One Board

General Description

The OS2/13 and OS2/14 are similar oscillators, designed to form part of sequential tone test oscillator OS1/1. Each produces two fixed frequencies, as follows:

- OS2/13, 60 and 900 Hz,
- OS2/14, 5 and 10 kHz.

Each oscillator comprises two printed circuit boards, one for each frequency. The two boards are housed in a chassis CH1/18C which plugs into a bay mounting panel PN3/23. The same index peg positions, 6 and 9, are used for both oscillators.

Each board carries a two-stage Wien-bridge controlled circuit (Fig. 1), which maintains oscillation at a frequency determined by C1 and C2. The preset variable resistor RV1 is provided to permit output-level adjustment if a component has to be renewed.

Except for the value of C1 and C2, all four circuits are identical. With the same exception, they are also identical with the oscillator circuit of the OS2/15, of which a fuller description is given.

Frequency-determining Capacitors

C1 and C2 have both the same value, as follows:

Unit	Frequency (Hz)	C1 = C2 (μF)
OS2/13	60	0.4737
	900	0.03158
OS2/14	5,000	0.005684
	10,000	0.002842

Test Data

Power Requirements

- Supply voltage, 24.5 volts d.c.
- Total current, 15.4 ± 1.5 mA.
- (Current per board, 7.7 mA.)

Typical Voltages

The following are typical voltages, measured with an Avometer Model 8 on the lowest practicable

range.

<i>Points of Measurement</i>	<i>TR1</i>	<i>TR2</i>
Collector/Emitter	1·8	6·0
Emitter/Common Positive	1·6	3·2

Frequencies

With an output level of +1·8 dB into a 4·7-kilohm load, the frequencies should be:

OS2/13, 60 ± 2 and 900 ± 20 Hz,
OS2/14, $5 \pm 0·1$ and $10 \pm 0·2$ kHz.

Output Level

The output level from any circuit board into a 4·7-kilohm load should be +1·8 dB. This measurement should be made with an amp.-det. calibrated against an SLP/3.

If the required level is not obtained:

1. Adjust RV1.
2. To correct any residual error of less than 0·5 dB, alter the value of R11.
3. If the residual error after operation (1) is greater than 0·5 dB, renew TH1 and start again.

RAYK(X) 12/67