

FIXED FREQUENCY OSCILLATOR OS2/21

Introduction

The OS2/21 comprises two similar oscillator circuits in a single unit. Each circuit is designed to supply the bias and erase currents required by a magnetic recording system. The frequency of operation is 60 kHz.

Each oscillator is constructed on a printed-wiring board and the two boards are mounted on a CH1/18 chassis with index-peg positions 6 and 30. An external power supply is required.

General Specification*Frequency of Operation*

Both Oscillators 60 kHz nominal

Intended Erasing-head Inductance

Oscillator No. 1 about 1.5 mH
Oscillator No. 2 about 2 mH

Intended Recording-head Inductances

Oscillator No. 1 about 7 mH
Oscillator No. 2 60—80 mH

Power Requirements

Oscillator No. 1	175 mA d.c. at 24.5 V
Oscillator No. 2	70 mA d.c. at 24.5 V

Circuit Description

The circuit diagram is given in Fig. 1. The two oscillators are basically similar but differ in the type of transformer employed and in the configuration of the output connections. Bias and erase-current outputs from Oscillator No. 1 are taken from separate secondary windings, the winding supplying the erase current being tuned by C6 and C7. The outputs from Oscillator No. 2 are taken from a single winding, the potential of the bias output being reduced by the capacitive potential divider C8, C9, which combines with C6 and C7 to tune the winding.

The 1-ohm resistors (R5) in the erase-current output circuits of both oscillators are provided to facilitate test measurements.

DEH/TES 3/69

See overleaf for Fig. 1.

from EB 12285
parts list EA 12206

OSCILLATOR No 1

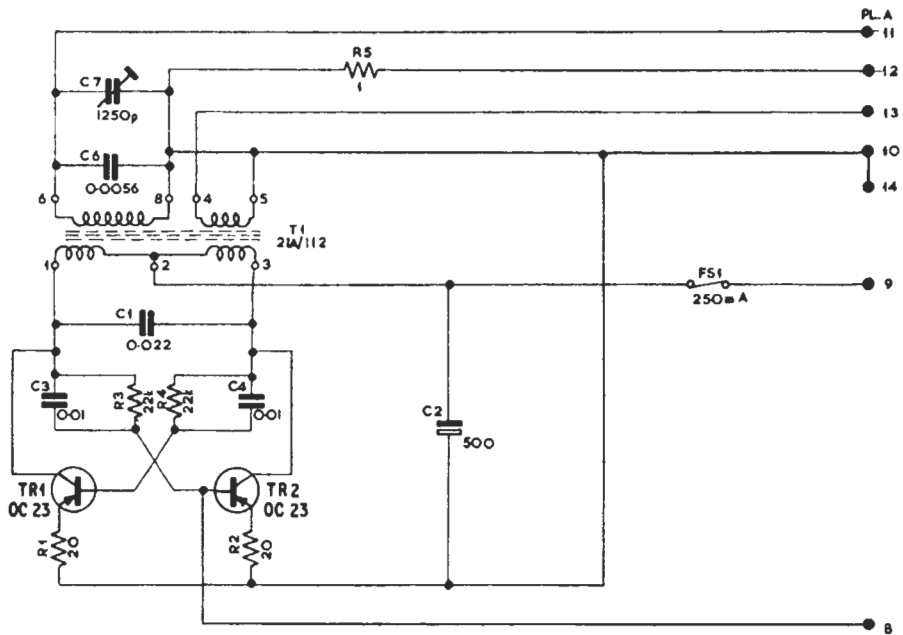

OSCILLATOR No 2

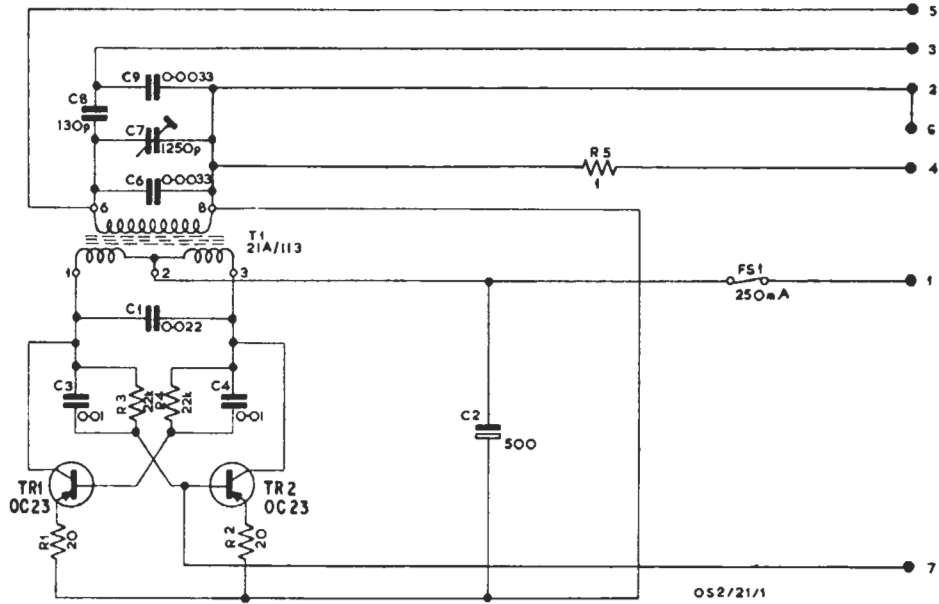

TRANSISTOR
ELECTRODES IDENTIFICATION



Fig. 1 Circuit of the Oscillator OS2/21