

DESTINATION TELEPHONE PANELS PA8/274 AND 275

*See also UN10/12**

* Instruction to be issued in autumn 1972.

Introduction

The PA8/274 incorporates in one unit all the keys, lamps and relays required for the termination of an E.M.X. and a destination telephone line on a sound control desk. It also contains a UN10/12 telephone unit and a buzzer for use in common with other telephone panels. It was designed for use with the Type-D range of control modules, and may not be suitable for other systems.

The PA8/275 carries a duplicate set of ring and answer keys, call and engaged lamps and a telephone unit UN10/12 for use with a second handset. For both panels the equipment is mounted in a modified CH1/37G chassis, having overall dimensions of 7 by 2¼ by 10½ inches.

General Description*Panel PA8/274*

The front panel mounts a 12-volt bleep-tone buzzer unit, E.M.X. and destination call and engaged lamps and two ring/answer keys. Inside the chassis are mounted DL, XL, LFD, LFX, RGD and RGX relays and telephone unit UN10/12. A telephone Type 713, mounted separately, is also required.

Panel PA8/275

The equipment on this panel is the same except that no buzzer or relays are fitted.

Circuit Description.*Panel PA8/274 (Fig. 1)*

The relays, lamps and telephone operate from a 50-volt d.c. supply, and a 17-Hz supply is required for ringing. The E.M.X. and destination circuits are almost identical, and the destination circuit will be described. Ringing tone of the destination line operates relay DL, thus completing the circuit for the buzzer, and operating relay LFD. Contact LFD1 holds the relay and contact LFD2 lights the call lamp. Contact LFD3 is in the circuit which brings up the mains white lamp.

The telephone is connected across the line by the operation of the answer key, and at the same time relay LFD is released, extinguishing the call lamp and lighting the engaged lamp. Cue programme on the destination line may also be fed out. Operation of the key to *Ring* energises relay RGD, which connects the 17-Hz supply to line. R1, R2, D5, D6 give protection to apparatus taking cue programme on the control line by limiting the incoming ringing voltages to about 3 volts.

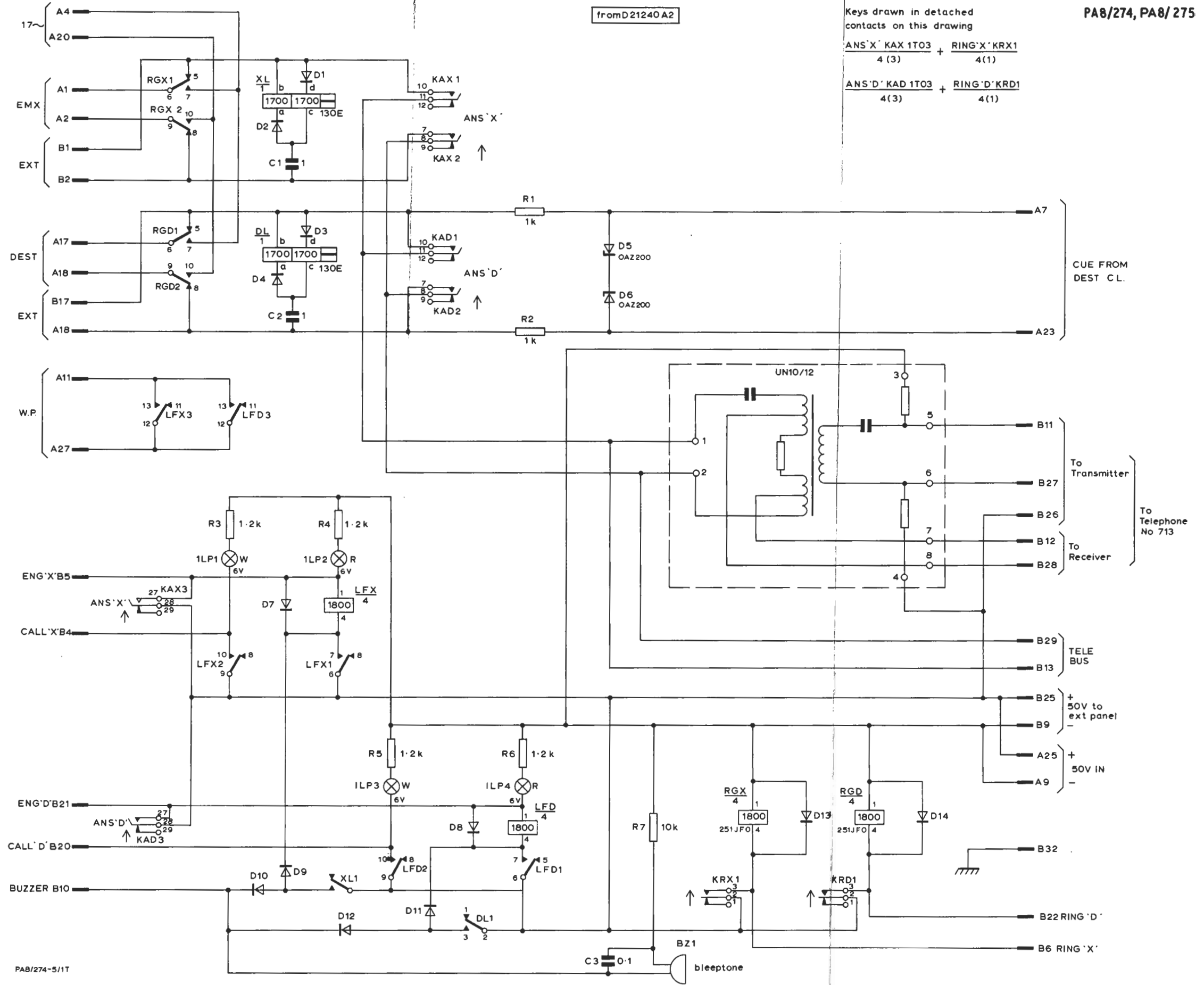

Keys drawn in detached contacts on this drawing

ANS 'X' KAX 1T03 + RING 'X' KRX1
4 (3) + 4 (1)

ANS 'D' KAD 1T03 + RING 'D' KRD1
4 (3) + 4 (1)

from D21240A2

CUE FROM DEST CL.

To Transmitter

To Receiver

To Telephone No 713

TELE BUS

+ 50V to ext panel

+ 50V IN

PA8/274-5/1T

D1 TO D4 & D7 TO D14 TYPE CG80H

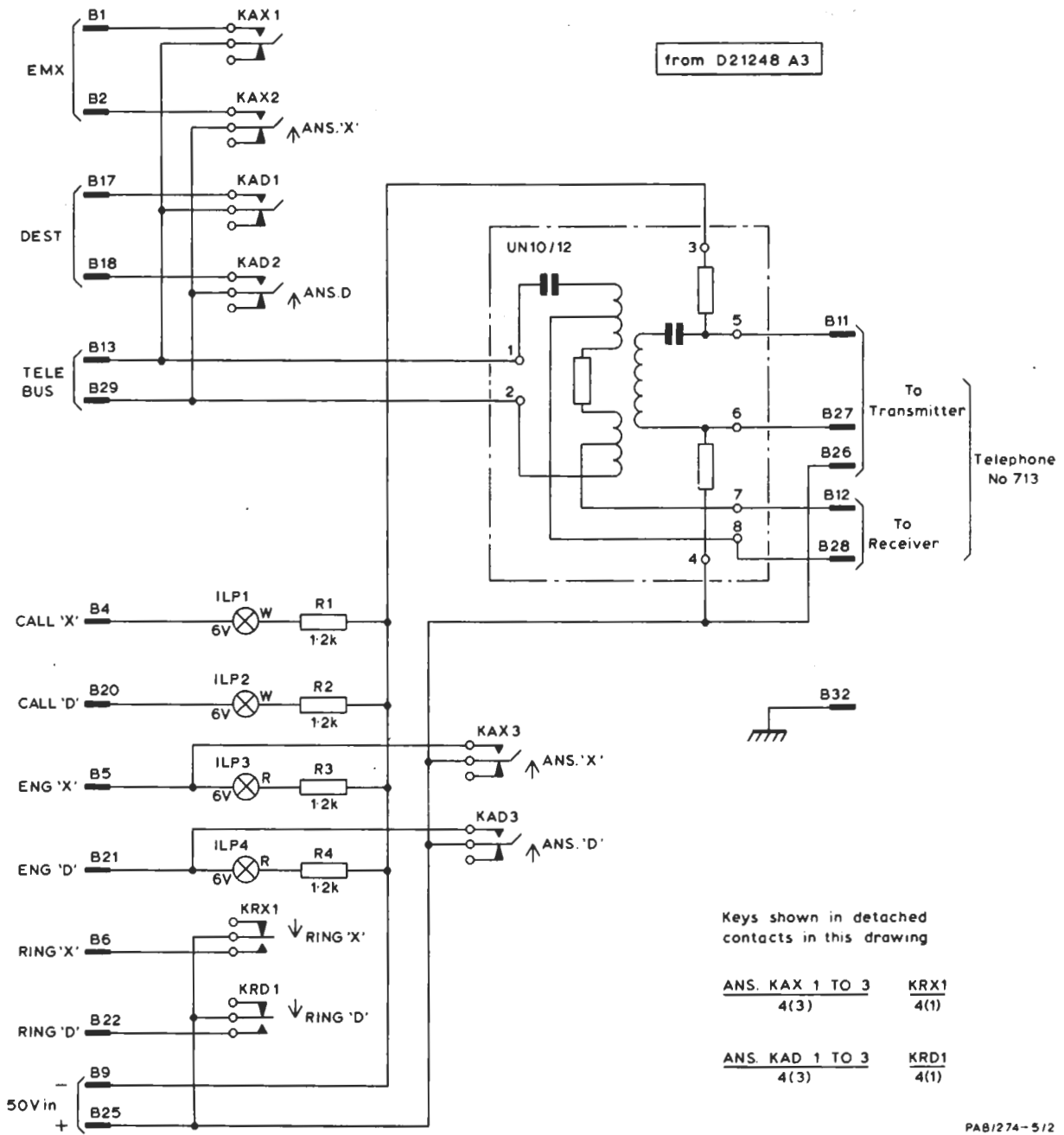

Fig. 2. Circuit of the PA8/275

PA8/274-5/2

Panel PA8/275 (Fig. 2)

The circuit of the PA8/275 is the same as that of the PA8/274 with the exceptions mentioned in the General Description.

Test Procedure

Apparatus Required

- Telephone No. 713
- Telephone Type F
- Four 6-volt P.O. No. 2 Lamps
- Four 1.2-kilohm Resistors
- 50-volt d.c. Supply
- 17-Hz Ringing Supply
- Tone Source TS/10
- A.C. Test Meter ATM/1 (as high-Z amp.-det.)

Connections

1. Connect the terminals of the telephone No. 713 to the panel terminals as follows:

- 2 to B12
- 7 to B28
- 8 to B11
- 9 and 4 to B27
- 5 to B26

2. Connect the 50-volt d.c. supply negative side to A9 and the positive side to A25.
 3. Connect a 6-volt lamp in series with a 1.2-kilohm resistor between each of the pairs A9 - B4, A9 - B5, A9 - B21.

Panel PA8/274

1. Connect a telephone Type F to R13, B29 and check for satisfactory speech between this and the No. 713 telephone.
2. Apply 17-Hz ringing to A1, A2. The buzzer should sound for the period of the ring, and the *E.M.X.* call lamps should light and remain lit after cessation of ringing. Continuity should be found between A11, A27.
3. Operate the *E.M.X.* answer key. The call lamps should be extinguished, and the engaged lamps lit. Continuity should now be found between A1 - B13 and A2 - B29.
4. Operate the *E.M.X.* ring key. Continuity should be found between A1 - A4 and A2 - A20, and that previously found between A1 - B1 and A2 - B2 should disappear.
5. Apply 17-Hz ringing to A17, A18. The buzzer should sound for the duration of the ring, and the *Dest.* call lamps should light and remain lit after cessation of ringing. Continuity should be found between A11, A27.
6. Operate the *Dest.* answer key. The call lamps should be extinguished and the engaged lamps lit, and continuity be found between A17 - B13 and A18 - B29.
7. Operate the *Dest.* ring key. Continuity should be found between A17 - A4 and A18 - A20,

- and that previously found between A17 - B17 and A18 - B18 should disappear.
8. Connection of B10 - B25 should sound the buzzer.
9. Connection of B5 - B25 should light the *E.M.X.* engaged lamps.
10. Connection of B21 - B25 should light the *Dest.* engaged lamps.
11. Connection of B6 - B25 should establish the conditions in Test 4.
12. Connection of B22 - B25 should establish the conditions in Test 7.
13. Apply zero level tone to A17, A18 and check that it is received from A7, A23. Using the ATM/1 as a high-impedance amplifier-detector, no appreciable attenuation should be found.
14. Apply ringing current to A17, A18. Appreciable attenuation should occur between these pins and A7, A23.

Panel PA8/275

This panel may be tested in conjunction with the PA8/274, in which case it is connected in place of the 6-volt lamps by linking the following corresponding pins on the two panels:- B4, B5, B6, B9, B20, B21, B22, B25.

Tests 9 to 12 may now be carried out by the use of the keys on the PA8/275.

WWM(X) 3/71