

## SECTION 3

### RELAY MATRIX UNITS PA9/503 AND PA9/504

#### Introduction

Matrix units PA9/503 and PA9/504 are switching units incorporating low-capacitance wire-contact relays which are suitable for use with video signals. Basically the units are similar but they differ in that the PA9/503 is designed for pulse distribution and the PA9/504 is designed for video distribution. These units are used in switching centres and in the regional operation centres for the routing of programme sources. In central apparatus rooms they are used for the routing and distribution of pulses and video signals and in studio apparatus rooms for mixer source selection and preview selection.

Both units are constructed using a number of relay panels Type PA17/505, each of which carries 12 relays and constitutes one input to the matrix unit. The pulse matrix unit provides 6 normal inputs and a spare input for emergency use; the video matrix provides 25 normal inputs and a spare. Both units have 12 outputs.

An input amplifier is associated with each relay panel and an output amplifier with each output bus-bar. The input amplifiers are Type AM1/511 (pulse) and AM1/514 (video); the output amplifiers are Type AM1/513 (pulse) and AM1/512 (video). Amplifiers are described in Instruction V.7.

In both units any source can be routed to any destination and any number of destinations can be connected to any one source but, to prevent the superimposition of sources, external interlocks are incorporated to ensure that each destination can only be connected to one source at a time.

#### Mechanical Description

Each matrix unit is constructed in a framework which fits into a standard 19-in. bay.

#### Video Matrix Unit

Fig. 3.1 shows the rear view of a PA9/504 video matrix unit. The relay panels (1) are mounted horizontally across the framework. To provide reasonable clearance between the input amplifiers (2) and also to give better air flow and cooling, provision is made for alternative mounting positions so that these amplifiers form two vertical rows; the output amplifiers (3) are mounted in a horizontal row across the centre of the unit.

Connections to the relay control circuits are by 31-way Painton connectors (4) mounted at the right-hand end of the relay panels. When bay wiring is completed it may not be possible for all the control circuit leads to reach the spare relay panel. The spare relay panel connections are therefore brought out on a flying lead, the loose end of which is normally held in a dummy plug (5) attached to the side of the power supply unit (6). Power supplies for the input and output amplifiers are taken via fuses (7, 8) grouped on fuse panels at the rear of the unit, to Painton 7-way connectors (9) on the backs of the input and output amplifiers.

The height of the PA9/504 unit is 28 inches and its weight is 80 lb.

#### Pulse Matrix Unit

The pulse unit differs, mechanically, from the video unit in the following ways:

- The output amplifiers and the associated fuse panel are mounted across the bottom of the unit.
- It has no integral power supply.
- Height 8.75 in.
- Weight 20 lb.

#### General Specification

##### Pulse Matrix Unit PA9/503

Voltage gain            0 dB  $\pm$  0.3 dB or  
6 dB  $\pm$  0.3 dB.

Maximum Input        d.c. -12 +6 volts;  
(across 75 ohms)     a.c. 6 volts p-p.

Hum                     Less than 1 mV p-p.

Crosstalk             -60 dB at all frequencies  
from 50 Hz to 5.5 MHz.

Power input            120 VA at 240 volts a.c.

##### Video Matrix Unit PA9/504

Voltage gain            0 dB  $\pm$  0.1 dB at 10 kHz.

Frequency Response    $\pm$ 0.1 dB from 10 kHz to  
5.5 MHz.

**Instruction V.13**  
**PA, Part 9, Section 3**

<i>k</i> rating (pulse-and-bar)	less than 0.5% for 4 routes in cascade.
Thermal stability	$\pm 0.2$ volt d.c. at the out- put for a variation of 10 to 40°C.
Maximum input (across 75 ohms)	d.c. $\pm 9$ volts; a.c. 6 volts p-p.
Differential phase distortion	less than 0.2° at 4.43 MHz.
Crosstalk	-60 dB at all frequencies from 50 Hz to 5.5 MHz.
Nonlinearity distor- tion	less than 0.5% with 10-step test.

**Circuit Description**

*Signal Circuits*

The signal circuits of both matrix units are similar except for the number of inputs; a simplified block diagram of a PA9/503 is shown in Fig. 3.2. Each relay panel acts as an input bus-bar and each of the relays, when energised, connects the input bus-bar to one of the 12 output bus-bars. Each relay panel is preceded by an input amplifier and each output bus-bar is followed by an output amplifier.

The impedance of each output bus-bar is 1.8 kilohms shunted by 47 pF. It is essential that the connection of a destination to a source does not affect the load on the input bus-bar; to achieve this each relay is arranged to connect either the associated output circuit or, in the de-energised position, a dummy load of 1.8 kilohms shunted by 47 pF. Thus the impedance of the input bus-bar remains constant at one-twelfth of this figure, and may be represented by 150 ohms in parallel with 560 pF.

*Relay Control Circuits*

The control circuits described below, though not an integral part of the matrix, are a necessary part of the electrical circuit.

The relays in the matrix unit may be operated by pushbuttons, rotary switches, motor-uniselectors or Ledex-operated switches. Where pushbuttons or manually operated rotary switches are used for relay control a slugging circuit is used to prevent two sources being connected, even momentarily, to the same destination. Where motor-uniselectors are used slugging is unnecessary since the supply

is interrupted during movement of the wipers.

Fig. 3.3b shows a simple slugging arrangement which may be used with a rotary switch which has break-before-make contacts; a switch with shorting contacts must not be used.

The 100- $\mu$ F capacitor in the operating circuit of each relay charges through a common 680-ohm resistor so that a delay of about 40 milliseconds occurs before the relay is energised. When the relay circuit is broken, a diode in the path between the capacitor and the relay coil prevents the capacitor from discharging through the relay, which therefore releases immediately. The capacitor discharges through the parallel resistor.

A more complicated arrangement (Fig. 3.3a) is used with pushbuttons that have a mechanical latch-bar. Two change-over contacts are used for each button and these are connected so that contact A breaks all supplies to the right of the button selected while contact B breaks all supplies to the left of that button. This arrangement ensures that two relays cannot be operated at once. It is necessary to use this arrangement with push-buttons since otherwise a sticking button, or the pressing of two buttons at once, would allow two relays to be energised.

*Power Supplies*

The amplifiers used in the pulse matrix unit obtain power from an external supply unit type PS2/503A. The amplifiers in the video matrix unit are powered from a type PS2/504 power supplier which forms an integral part of the matrix unit. Both units are described in Instruction G.2.

The PS2/504 provides two stabilised outputs, one at -11.5 volts and the other at +11.5 volts. Both outputs are rated at 4 amps and fused at 5 amps; the mains input is fused at 1 amp. Each supply has an output impedance of 5 milliohms and, to make full use of this, the amplifier associated with each power supply is provided with a separate terminal and connected to the point on the matrix unit, adjacent to the fuse panels, at which this low output impedance is required.

**Maintenance**

Routine maintenance is unnecessary but alignment should be checked if components have to be changed. If work is carried out on a matrix unit that is in service, a non-earthed low-voltage soldering iron should be used to avoid the possibility of accidentally shorting out signals.

If an input amplifier is faulty, service can be

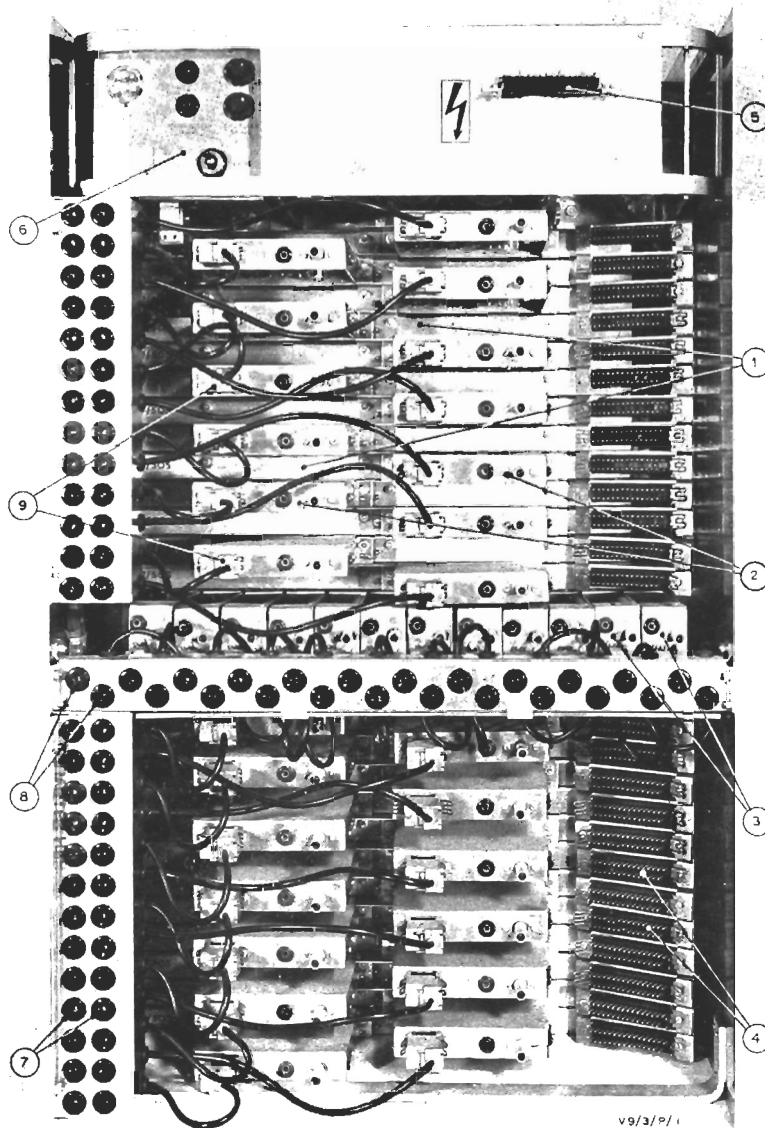
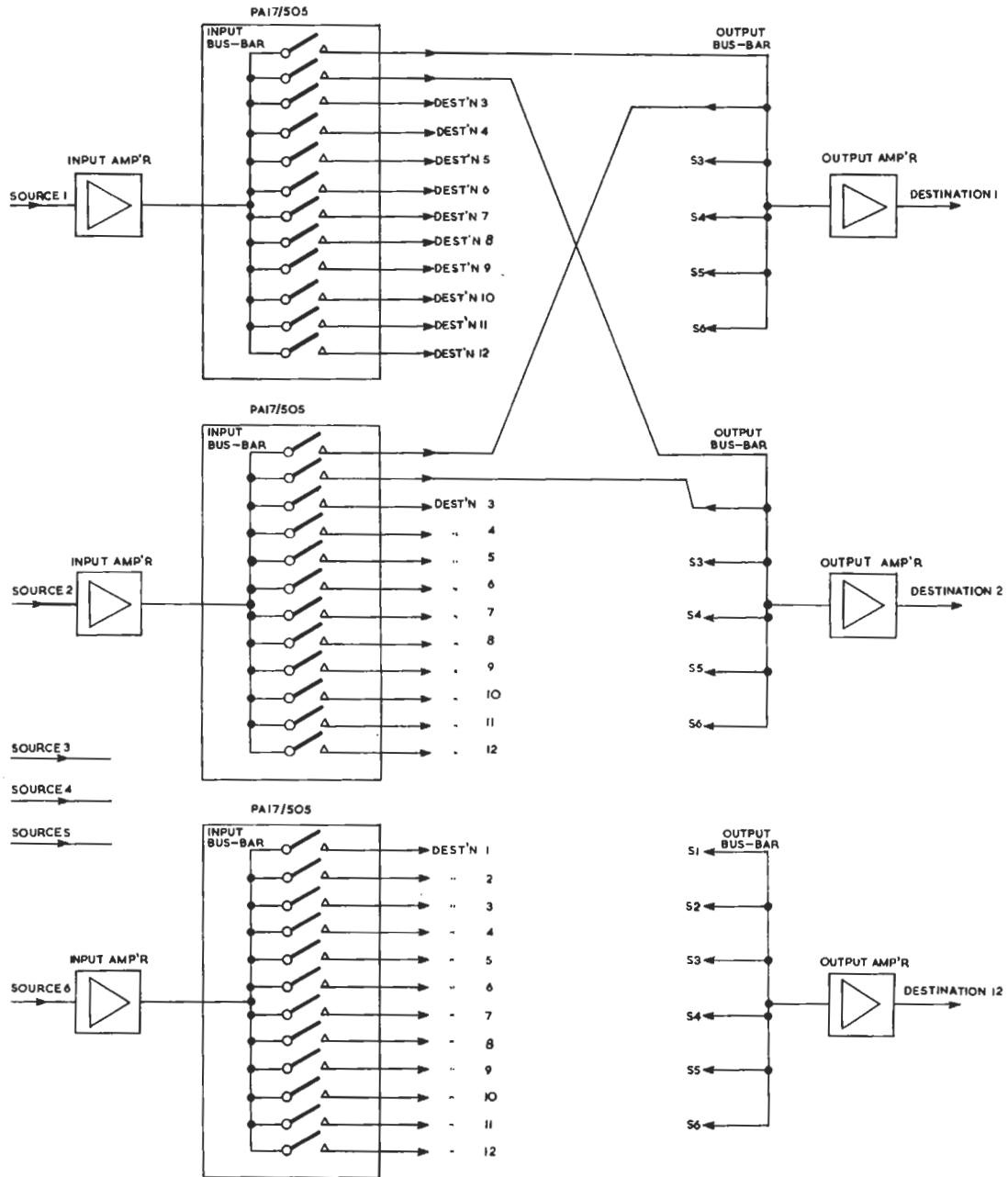

Fig. 3.1. Matrix Unit PA9/504: Rear View

Instruction V.13  
 PA, Part 9, Section 3



V9/3/4

Fig. 3.2. Matrix Unit PA9/503: Simplified Block Diagram

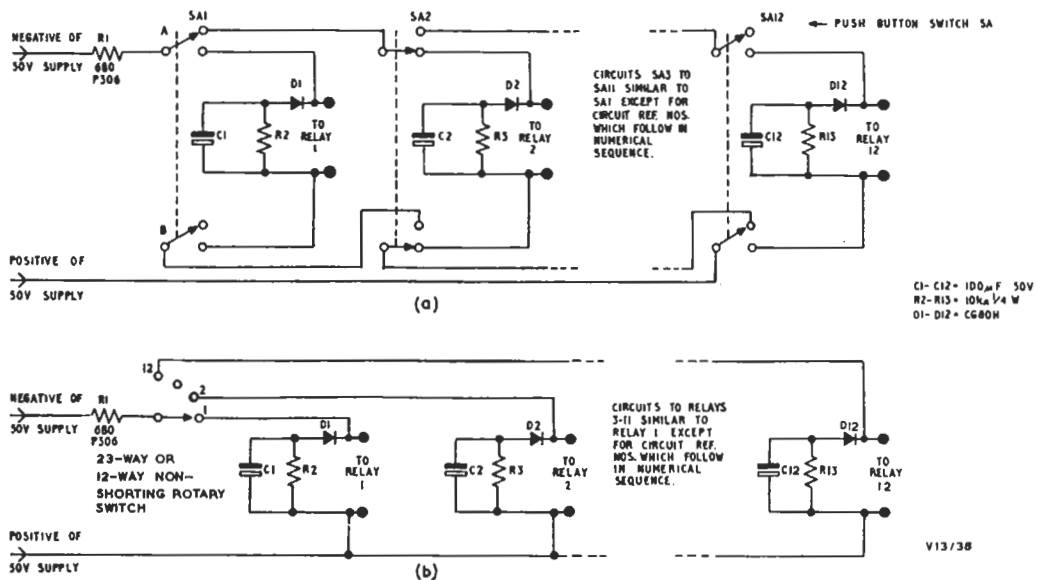

Fig. 3.3 Operating Circuits for Pushbuttons and Rotary Switches

restored by using the spare input facility. The control circuit connector for the spare input assembly is normally held in a dummy plug on the power supply cover. This is removed and joined to the 31-way connector which normally feeds the defective source strip. The coaxial input lead is then removed from the defective input amplifier and joined by an extension lead to the spare input.

#### To Change an Input Amplifier

1. Remove the 7-way connector and the coaxial input lead from the back of the amplifier.
2. Cut the wire connecting the output of the amplifier to the input tag post.
3. Take off the two 4-B.A. nuts which hold the amplifier to the relay strip and remove the amplifier.
4. Renew the output connection using a 2-in. length of 24-s.w.g. wire.
5. Bolt the replacement amplifier to the panel and reconnect the output.
6. Replace the 7-way power connector and the coaxial input lead.
7. Check that the amplifier is working and that the unit as a whole functions correctly.
8. Allow a 30-minute warm-up period and then adjust d.c. and gain controls as described below under *Re-alignment*.

#### To Change an Output Amplifier

1. Remove the power and output connectors on the back of the amplifier.
2. Remove the front cover of the matrix unit.
3. Cut the wire which connects the output bus-bar to the amplifier.
4. Remove the two 4-B.A. nuts which hold the amplifier in place.
5. Remove the amplifier by pulling it backwards and upwards over the horizontal fuse distribution strip; the upper fixing screws of the fuse strip may be removed and the strip hinged down to facilitate the withdrawal. (On early models the fuse distribution strip cannot easily be moved. On these units to remove amplifiers Nos. 3-6 it is necessary to remove the spare input amplifier to obtain enough clearance; to remove amplifiers Nos. 8-10 it may be necessary to slacken off the nuts which secure input amplifier No. 12.)
6. Bolt the replacement amplifier in position and renew the wire from the output bus-bar to the amplifier input.
7. Replace the 7-way power connector and the coaxial output lead.
8. Check that the amplifier is working and that the unit as a whole functions correctly.
9. Allow a 30-minute warm up period and then adjust d.c. and gain controls as described below under *Re-alignment*.

**Instruction V.13**  
**PA, Part 9, Section 3**

*To Change a Relay Strip*

1. Remove the 31-way relay-control connector.
2. Remove the associated input amplifier as described above.
3. Cut the twelve 24-s.w.g. wires which join the output of each relay to the associated output bus-bar.
4. Remove the twelve 8-B.A. screws which join the relay strip to the bus-bar screens and the four-B.A. screws which hold the relay strip to the main chassis.
5. Remove the relay strip from the rear of the unit.
6. Clean the ends of 24-s.w.g. wire from the intersection points on the output bus-bars and solder a new piece of wire to each.
7. Fit a replacement relay strip in the matrix unit and solder the twelve output terminals to the intersection points on the bus-bars.
8. Replace the input amplifier and the relay control connector.
9. Check that the operation of the relay strip is satisfactory.

*To Change a Power Supply*

On early models of the PA9/504 video matrix unit it was difficult to remove the power supply without removing the entire unit from the bay. Units made recently have been modified and it is now possible to change a power supply without interfering with the main unit.

To change a power supply in a modified PA9/504 proceed as follows:—

1. Remove the power input lead from the back of the unit and plug PLA from the bottom of the unit.
2. Remove the front cover of the matrix and unscrew the four 2-B.A. screws which fasten the power supply to the matrix chassis.
3. Remove the two 0-B.A. screws at the rear of the power unit which fasten the power unit to the sides of the matrix chassis.
4. Remove the power unit by sliding it out from the rear.
5. Replace the unit by carrying out the above steps in the reverse order.

**Re-alignment**

The following apparatus is required:

- Oscilloscope (suitable for d.c. measurement).
- Video change-over box (not needed if the oscilloscope has a differential measuring facility).

A source of test waveform is also required. A pulse signal is required for re-aligning the PA9/503 and either a sawtooth-and-syncs or pulse-and-bar signal for re-aligning the PA9/504.

These re-alignment instructions refer specifically to the PA9/504, but they can also be used for the PA9/503, providing it is borne in mind that the amplifiers in the PA9/503 do not have a zero d.c. adjustment and that the input amplifiers may have a gain of either 6 or 0 dB.

*Input Amplifier*

1. Remove the input signal and terminate the input in 75 ohms.
2. Connect the oscilloscope, set up for d.c. measurement, to the amplifier output.
3. Allow a 30-minute warm-up period and then adjust the d.c. control to bring the potential at the output to the same value as the potential on the output of the adjacent amplifier in the same unit.

Note:—This potential should be zero volts but, because of ambient temperature variations, it is inadvisable to align to zero volts unless the entire matrix unit is being re-aligned.

4. Remove the termination and apply a test signal to the input amplifier; route this signal through any convenient output amplifier.
5. Use the change-over box, or the differential facility of the oscilloscope, to compare the input and output signals. Adjust the amplifier gain control to give 0 dB gain for the input/output combination.

Note:—This may be 6 dB gain for PA9/503 input amplifiers.

*Output Amplifier*

1. Connect the input terminal to earth.
2. Connect the oscilloscope, set up for d.c. measurement, to the output.
3. Allow a 30-minute warm-up period and then adjust the d.c. control to bring the potential at the output to the same value as the potential on the output of an adjacent amplifier in the same unit.

Note:—This potential should be zero volts but, because of ambient temperature variations, it is inadvisable to align to zero volts unless the entire matrix unit is being re-aligned.

4. Remove the short circuit on the amplifier input.

5. Apply a test signal to a convenient input amplifier and route this to the amplifier being re-aligned.
6. Use the change-over box, or the differential

facility of the oscilloscope, to compare the input and output signals. Adjust the amplifier gain control to give 0 dB gain for the input/output combination.

TES 9/65