

STABILISED POWER SUPPLIERS

PS2/13A-R

PS2/21A-F

PS2/22A-F

PS2/86

Introduction

These power suppliers are all variants of one basic type and give output voltages of 6, 12, 18, 24 or 36 volts. They all employ the same circuit configuration, differing only in mechanical details. All units use printed circuit cards and require an input voltage of 240 volts $\pm 6\%$, 50Hz. Individual performance characteristics are given in Table 1.

In the PS2/22 series the units are not mounted in individual chassis but are intended to be mounted with other apparatus in existing CH1/12A chassis. The suffix letters have the same meanings as for the PS2/21 series with the addition of the PS2/22F which has an output of 12 volts with an improved performance and long term stability.

This series of power suppliers is superseded by

TABLE 1

Parameter	PS2/13, PS2/21, PS2/22					PS2/86	
	6	12	18	24	36	5	12
Nominal Output Voltage	6	12	18	24	36	5	12
Output Current Max. amps.	0.5	0.5	0.333	0.25	0.166	0.5	0.5
Output Voltage Range no load	5.5—7.0	11.5—13	17.5—19.0	23.0—25.5	34.0—38.0	4.4—5.5	11.5—13
Output Impedance at l.f. (ohms)	0.5	0.5	0.5	0.5	0.5	0.5	0.5
Regulation (% change of output volts with 5.0% mains input variation*)	1.0	1.0	1.0	1.0	0.2	0.5	1.0
Ripple Content p-p mV	5	5	5	5	5	5	5
Max. Ambient Temp. °C	45	45	45	45	45	45	45
Thermal Stability mV/°C	7	7	7	7	4	7	3

*7.5% for PS2/86

The PS2/13 series of units each consists of two units mounted in a CH1/12A chassis. Table 2 lists the suffix letters of the codes with the output voltages available from the units; index peg numbers are also given.

In the PS2/21 series each supplier consists of one unit mounted in a CH1/12A chassis. The suffix letters A to F correspond to the various output voltages. These, with index-peg numbers are listed in Table 3. PS2/21F contains a PS2/22F card.

PS2/91, PS2/92 and PS2/93.

The PS2/86 employs a slightly modified PS2/22A (see Fig. 4) and a PS2/22F mounted together in a CH1/12A chassis.

Circuit Description

The circuit diagrams are given in Fig. 1, Fig. 2, Fig. 3 and Fig. 4 along with component values for the various versions.

The circuit employed for all units is conventional.

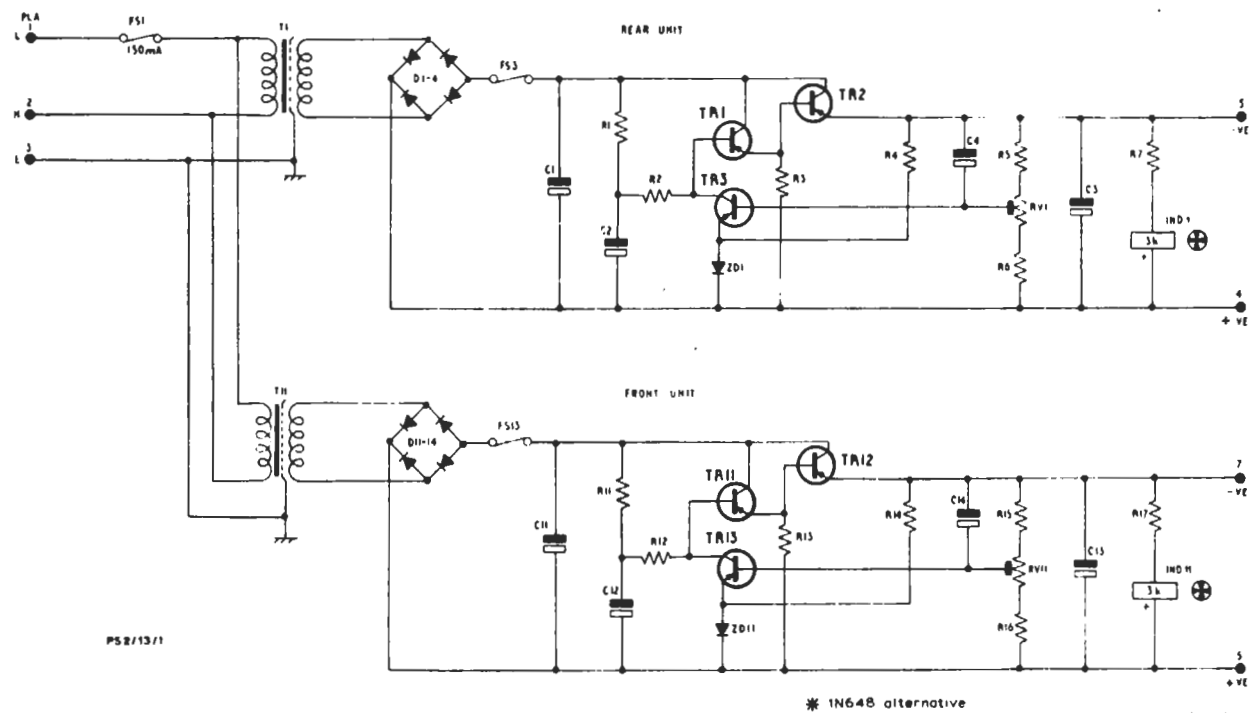

from DD11359 iss. B
Parts Lists OA11360
DA11456
10
DA11469

TRANSISTOR ELECTRODE IDENTIFICATION

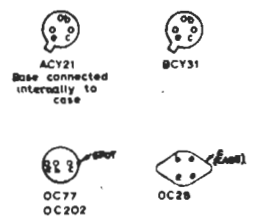

* 1N648 alternative

* *

UNIT	VOLTAGE		C1	C2	C3	C4	C11	C12	C13	C14	R1	R2	R3	R4	R5	R6	R7	R11	R12	R13	R14	R15	R16	R17	TR1	TR2	TR3	TR11	TR12	TR13	D1-4	D11-14	ZD1	ZD11	RV1	RV11	T1	T11	FS1	FS15															
	REAR	FRONT																																																					
PS2/13A	0	6	2000	25	250	25	2000	25	250	25	2.2k	2.7k	2.2k	310	180	330	10	2.2k	2.7k	2.2k	510	180	330	10	ACY21	OC28	OC202	OCY21	OC28	OC202	1N648	1N648	1N55P	1N527P	100	100	M302	M302	1A	1A															
PS2/13B	5	12	2000	25	250	25	1000	25	280	25	2.2k	2.7k	2.2k	310	180	330	10	4.7k	3.3k	3.9k	1.2k	910	1k	1.2k	ACY21	OC28	OC202	OCY21	OC28	OCY31	1N648	1N648	1N35F	DAZ202	100	220	M302	M304	1A	1A															
PS2/13C	0	18	2000	25	250	25	250	25	250	12	2.2k	2.7k	2.2k	510	180	330	10	4.7k	3.3k	3.9k	2.4k	1.6k	820	33k	ACY21	OC28	OC202	OCY21	OC75	OCY31	1N648	1N648	1N35F	DAZ202	100	220	M302	M303	1A	500mA															
PS2/13D	0	24	2000	25	250	25	250	25	250	12	2.2k	2.7k	2.2k	510	180	330	10	4.7k	3.3k	3.9k	2.4k	1.6k	820	56k	ACY21	OC28	OC202	OC77	OC28	OCY31	1N648	1N648	1N35F	DAZ202	100	470	M302	M305	1A	500mA															
PS2/13E	0	36	2000	25	250	25	100	25	250	12	2.2k	2.7k	2.2k	510	180	330	10	4.7k	3.3k	3.9k	2.4k	1.6k	820	56k	ACY21	OC28	OC202	OC77	OC28	OCY31	1N648	1N648	1N35F	DAZ202	100	470	M302	M301	1A	250mA															
PS2/13F	12	12	1000	25	220	25	1000	25	220	25	4.7k	3.3k	3.9k	1.2k	910	1k	1.2k	4.7k	3.3k	3.9k	1.2k	910	1k	1.2k	ACY21	OC28	OCY31	OCY21	OC28	OCY31	1N648	1N648	DAZ202	DAZ202	220	220	M304	M304	1A	1A															
PS2/13G	12	18	1000	25	250	25	250	25	220	12	4.7k	3.3k	3.9k	1.2k	910	1k	1.2k	4.7k	3.3k	3.9k	1.2k	910	1k	1.2k	ACY21	OC28	OCY31	OCY21	OC28	OCY31	1N648	1N648	DAZ202	DAZ202	220	220	M304	M303	1A	500mA															
PS2/13H	12	24	1000	25	250	25	250	25	280	12	4.7k	3.3k	3.9k	1.2k	910	1k	1.2k	4.7k	3.3k	3.9k	1.2k	910	1k	1.2k	ACY21	OC28	OCY31	OC77	OC28	OCY31	1N648	1N648	DAZ202	DAZ202	220	470	M304	M305	1A	500mA															
PS2/13J	12	36	1000	25	250	25	130	25	280	12	4.7k	3.3k	3.9k	1.2k	910	1k	1.2k	4.7k	3.3k	3.9k	1.2k	910	1k	1.2k	ACY21	OC28	OCY31	OC77	OC28	OCY31	1N648	1N648	DAZ202	DAZ202	220	220	M304	M301	1A	250mA															
PS2/13K	18	18	250	25	250	12	250	25	250	12	4.7k	3.3k	3.9k	2.4k	1.6k	820	33k	4.7k	3.3k	3.9k	2.4k	1.6k	820	33k	ACY21	OC28	OCY31	OCY21	OC28	OCY31	1N648	1N648	DAZ202	DAZ202	220	220	M303	M305	500mA	500mA															
PS2/13L	18	24	250	25	250	12	250	25	250	12	4.7k	3.3k	3.9k	2.4k	1.6k	820	33k	4.7k	3.3k	3.9k	2.4k	1.6k	820	33k	ACY21	OC28	OCY31	OC77	OC28	OCY31	1N648	1N648	DAZ202	DAZ202	220	470	M303	M305	500mA	500mA															
PS2/13M	18	36	250	25	250	12	100	25	250	12	4.7k	3.3k	3.9k	2.4k	1.6k	820	33k	4.7k	3.3k	3.9k	2.4k	1.6k	820	33k	ACY21	OC28	OCY31	OC77	OC28	OCY31	1N648	1N648	DAZ202	DAZ202	220	470	M304	M301	500mA	250mA															
PS2/13N	24	24	250	25	250	12	250	25	250	12	4.7k	3.3k	3.9k	2.4k	1.6k	820	33k	4.7k	3.3k	3.9k	2.4k	1.6k	820	33k	ACY21	OC28	OCY31	OC77	OC28	OCY31	1N648	1N648	DAZ202	DAZ202	220	470	M305	M305	500mA	500mA															
PS2/13P	24	36	250	25	250	12	100	25	250	12	4.7k	3.3k	3.9k	2.4k	1.6k	820	33k	4.7k	3.3k	3.9k	2.4k	1.6k	820	33k	OC77	OC28	OCY31	OC77	OC28	OCY31	1N648	1N648	DAZ202	DAZ202	470	470	M305	M301	500mA	250mA															
PS2/13Q	36	36	100	25	250	12	100	25	250	12	4.7k	3.3k	3.9k	2.4k	1.6k	820	33k	4.7k	3.3k	3.9k	2.4k	1.6k	820	33k	OC77	OC28	OCY31	OC77	OC28	OCY31	1N648	1N648	DAZ202	DAZ202	470	470	M301	M301	250mA	250mA															
PS2/13R	12	18	1000	25	250	12	1000	25	250	125	4.7k	3.3k	3.9k	620	750	1k	1.2k	4.7k	3.3k	3.9k	620	750	1k	1.2k	ACY21	OC28	OCY31	ACY21	OC28	OCY31	1N648	1N648	1N35F	1N35F	150	150	M304	M304	1A	1A															

PS2/13R CONTAINS 2 PS2/22F

Fig. 1 Circuit of Power Supplier PS2/13

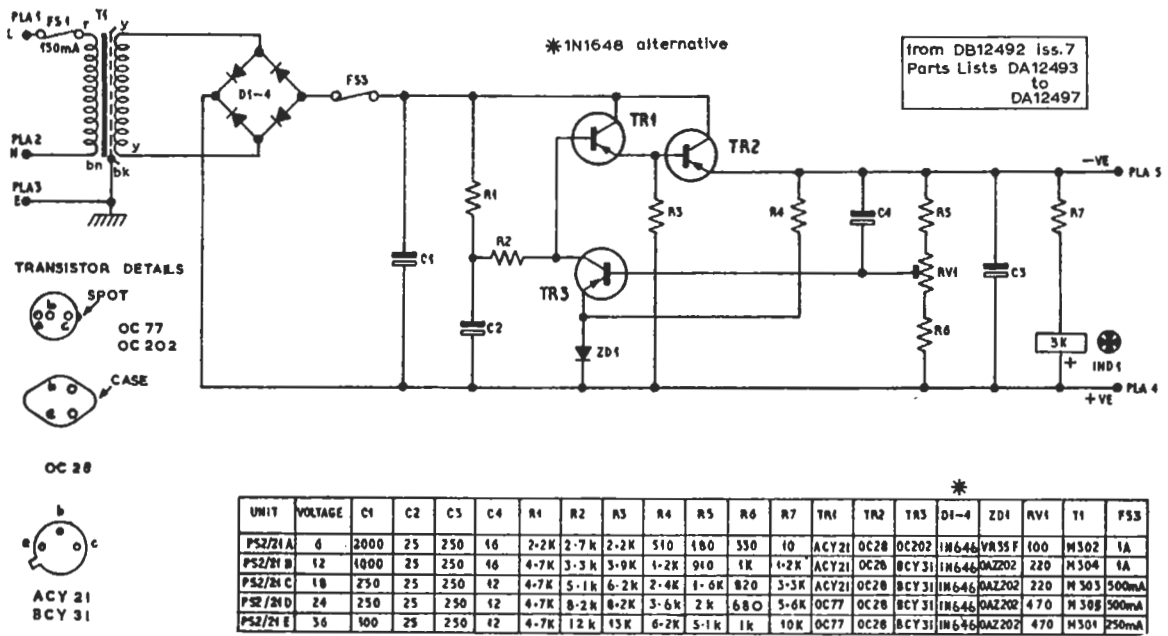

Fig. 2 Circuit of Power Supply PS2/21

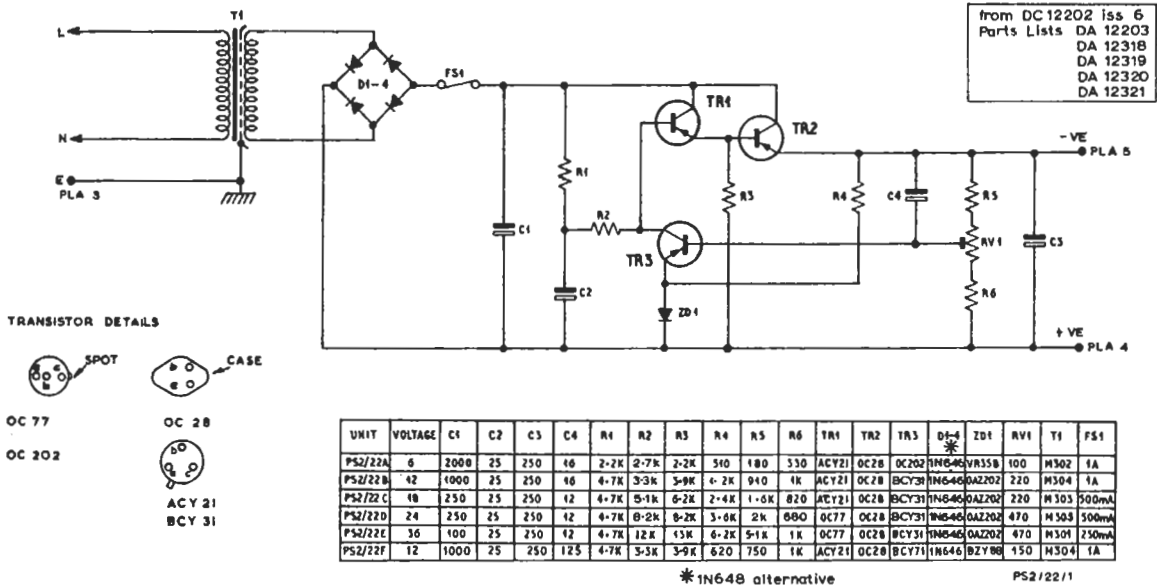

Fig. 3 Circuit of Power Supply PS2/22

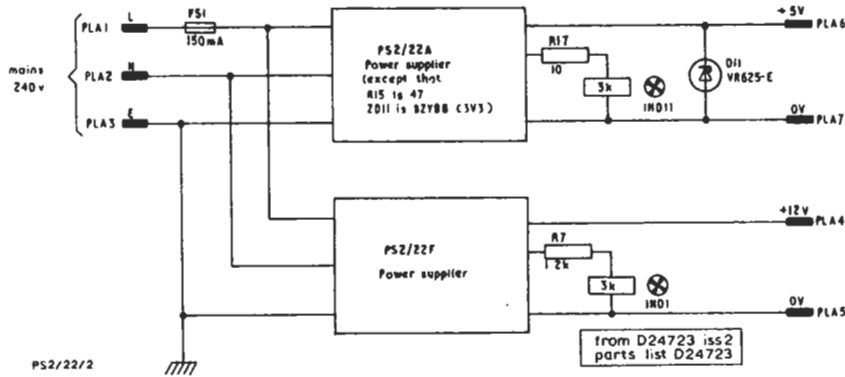

Fig. 4 Circuit of Power Supplier PS2/86

TABLE 2
 PS2/13 Series

Suffix Letter	Output Voltages		Index Pegs
	Rear	Front	
A	6	6	2 and 10
B	6	12	2 and 12
C	6	18	2 and 14
D	6	24	2 and 16
E	6	36	2 and 18
F	12	12	2 and 11
G	12	18	2 and 13
H	12	24	2 and 15
J	12	36	2 and 17
K	18	18	4 and 8
L	18	24	4 and 10
M	18	36	4 and 12
N	24	24	4 and 14
P	24	36	4 and 16
Q	36	36	4 and 18

The zener diode provides the reference potential and RV1 (or RV11) provides output voltage adjustment. C3 and C4 are used to reduce the effects of h.f. disturbances. IND1 gives a signal that the unit is working but does not necessarily indicate correct functioning. The maltese cross pattern shows the *on* condition and an all black pattern shows the *off* condition.

Maintenance

Regular maintenance is not required but an occasional check should be made to ensure that the performance is as shown in Table 1.

References

1. Designs Specification No.7.9(63)
2. Designs Department Specification No.7.16(64)
3. Designs Department Specification No.9.119(69)