

SECTION 7

RECEIVERS RC5/4, RC5/4A and RC5/5

Introduction

The RC5/4 and the RC5/4A are v.h.f. f.m. rebroadcast receivers which supersede receivers RC5/2 and RC5/3. The RC5/5 is similar but operates in the u.h.f. band. All three receivers incorporate carrier-failure detection circuits. They operate from an a.c. mains power supply but include facilities for automatic change-over to a battery supply if the mains fails.

The receivers consist of a number of plug-in units mounted in a general purpose mounting panel type PN3/23 with dimensions 18 in. by 5¼ in. The plug-in units are:

Input R.F. Unit	UN1/39 (RC5/4 and RC5/4A) UN1/57 (RC5/5)
I.F. Bandpass Filter	FL2/4
First I.F. Amplifier	UN1M/56 (RC5/4A only)
I.F. Unit	UNI/41
Discriminator and Relay Unit	UNI/52
Line Receiving Amplifier	AM7/4
Line Sending Amplifier	AM7/2
Power Supplier	PS2/9

The first four units (excepting the FL2/4) are constructed on CH1/27 chassis and the remaining three units on CH1/18C chassis; they are positioned on the PN3/23 panel from left to right in the order given. The FL2/4 is built in a copper box which is mounted on the back of the receiver. All connections are made by means of multi-way plugs and sockets.

Certain r.f. connections, including the aerial input, are brought out to B.N.C. sockets which are mounted externally and to the rear of the receiver. In addition an 8-way Painton plug,

also mounted at the rear, carries a programme muting circuit, an alarm circuit, connections for an emergency battery supply and the main audio output.

General Specification

<i>Frequency Range</i>	85 - 97 MHz (RC5/4 and RC5/4A) 470 - 582 MHz (RC5/5) 606 - 960 MHz (RC5/5)
<i>Minimum Input Level</i>	100 µV (RC5/4) 30 µV (RC5/4A) 100 µV (RC5/5)
<i>Audio Output Level (deviation ± 75 kHz)</i>	+12 dB (reference 1 mW)
<i>Variation of Output Level with Input Level</i>	Less than 0.5 dB over the range: 100 µV - 10 mV (RC5/4 and RC5/5) 30 µV - 1 mV (RC5/4A)
<i>Harmonic Distortion at 1 kHz</i>	Better than 6 dB
<i>Signal/noise Ratio (weighted)</i>	100 µV input greater than 55 dB (RC5/4) greater than 60 dB (RC5/4A and RC5/5) 1 mV input greater than 65 dB
<i>A.M. Rejection (40 dB minimum)</i>	100 µV input (RC5/4) 20 µV input (RC5/4A)
<i>Image Rejection</i>	Greater than 60 dB
<i>Power Supplies</i>	240 V a.c., 75 mA 24 V d.c., 350 mA

General Description

The receivers are of the superheterodyne type and use the standard i.f. of 10.7 MHz. A block diagram of the RC5/4A is given in Fig. 7.1; when the extra i.f. unit UN1M/56 is eliminated

Instruction RS.2
Section 7

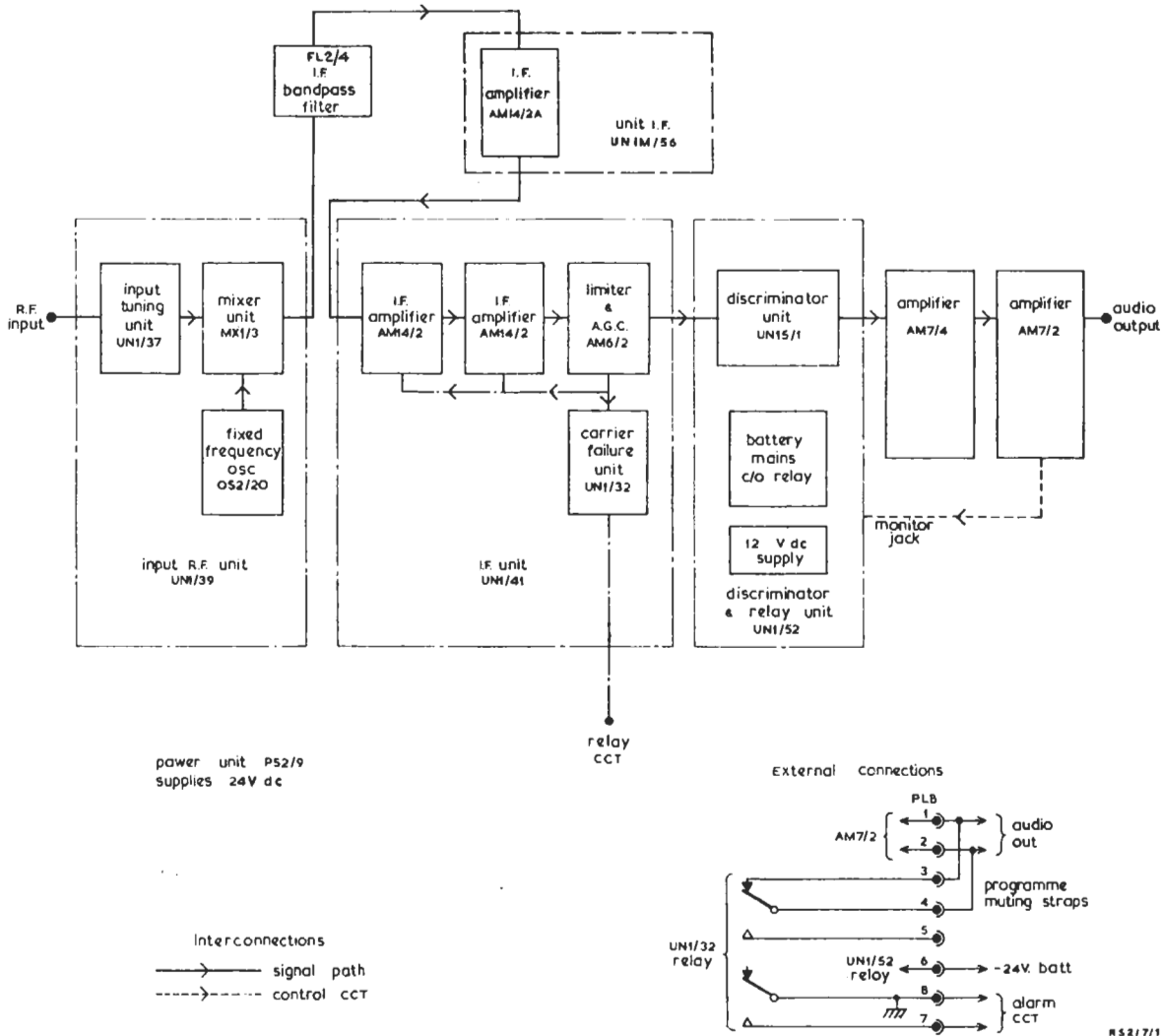

Fig. 7.1. Receiver RC/54: Block Diagram

this diagram serves also for the RC5/4. The receiver type RC5/4A is intended for use under conditions of low signal strength. The RC5/5 is essentially the same as the RC5/4 but it uses a u.h.f. input unit type UN1/57.

Note: units UN1/39 and UN1/41 are used also in the Translator EP7/5 and are described in Instruction T.12. Similar i.f. and discriminator circuits are described in Instruction RM.1 (Receiver RC4/1).

The audio amplifiers (AM7/2 and AM7/4) are described in Instruction S.10 and the power supplier (PS2/9) in Instruction G.2.

Detailed Description

R.F. Unit UN1/39 (Figs. 18 and 19)

This unit comprises an Input-tuning Unit UN1/37, a Mixer Unit MX1/3 and an Oscillator Unit OS2/20.

The input-tuning unit, which consists of two tuned circuits with shunt capacitance coupling, has a bandwidth of about 2 MHz at the 3-dB points. The degree of coupling depends on C3 which is adjusted during the initial line-up and should not require attention.

The mixer circuit comprises an r.f. amplifier (TR1) and a diode mixer (DI). A tuned buffer

stage (TR2) provides the necessary level of oscillator drive. The i.f. is extracted by a bandpass filter (L3, L4 and the associated capacitors) which provides an output impedance of 50 ohms. The conversion gain of the mixer is 6 dB and the noise factor is 12 dB.

The crystal-controlled oscillator operates at a frequency 10.7 MHz below that of the required input frequency and produces an output voltage of 200 - 300 mV across 75 ohms. The crystal, which operates in its series-resonant mode, is mounted in a small oven but the temperature-control circuits are not used. A buffer amplifier (TR2) feeds the tuned output stage (TR3). The output tuned-circuit (L3, C14, C15 and the variable capacitor C13) is tapped, at the junction of C14 and C15, to obtain an output impedance of 75 ohms; inductor L3 is made variable so that the output impedance can be adjusted by varying the L/C ratio (i.e. the impedance) of the tuned circuit.

R.F. Unit UN1/57 (Fig. 20)

This unit operates in Bands 4 and 5 but has the same basic circuit as the UN1/39. It incorporates a series-capacitance-coupled bandpass r.f. filter and an r.f. amplifier both of which use line resonators. The local oscillator is a crystal-controlled Colpitts circuit and this is followed by a buffer amplifier, two frequency-treble stages and a tuned output stage which also uses resonant lines. The feed to the mixer stage is at low impedance. The mixer (TR2) is a common-emitter stage and the local-oscillator output is injected at the emitter. The r.f. input signal is applied to the base of TR2 and is isolated from the biasing arrangements by L2. The mixer output, at 10.7 MHz, is fed to the i.f. circuits via an impedance-matching bandpass filter as before.

I.F. Filter FL2/4

The FL2/4 is a four-stage bandpass filter which is used to improve the rejection of unwanted signals on the skirts of the i.f. passband. It has a characteristic impedance of 50 ohms and there are no recovery regions outside the passband. The attenuation characteristic is slightly asymmetrical in that it rises more rapidly on the low-frequency side of the passband than on the high-frequency side. Details of the filter are given in Fig. 7.2.

I.F. Unit UN1/41 (Fig. 18)

The i.f. unit is assembled from a number of

sub-assembly cards which include two i.f.-amplifier cards, a limiter-and-a.g.c.-circuit card and a carrier-failure-unit card; all but the last have individual screening boxes. The amplifier cards are connected together to form a.c.-coupled cascode stages and each card consists of a common-emitter stage which is aperiodically-coupled to a common-base stage with a tuned collector circuit. The two halves of each cascode stage are mounted on separate cards, and therefore in separate screening boxes, to isolate the high-impedance output circuit from the high-impedance input circuit. Thus the first cascode pair is formed by TR2 on the first amplifier card and TR1 on the second amplifier card; the second cascode pair is formed by TR2 on the second amplifier card and TR1 on the limiter-and-a.g.c. card. TR1 on the first amplifier card is used as a low-input-impedance tuned amplifier which, to some extent, matches the 50-ohm output impedance of the FL2/4. Each cascode stage provides a gain of about 30 dB with a bandwidth of 200 kHz.

In the limiter-and-a.g.c. card transistor TR1, which forms part of the second cascode stage, feeds the limiter (TR4) via capacitor C4. The limiter and TR1 in the discriminator circuit form another cascode stage which drives the discriminator transformer. The a.g.c. circuits are fed by a diode rectifier D1; the d.c. output from this, smoothed by R7 and C5, is fed to the a.g.c. amplifier (TR2 and TR3) and thence to (a) the carrier-failure circuit and (b) the i.f. amplifiers for gain-control purposes. The unsmoothed signal from the diode is a.c. coupled to the carrier-failure circuit but is not used in the RC5/4 receiver or in its variants.

The overall gain of the i.f. unit, including the limiter, is 65 dB maximum with a bandwidth of ± 100 kHz. The output impedance is 50 ohms.

The Carrier Failure Unit UN1/32, the circuit of which is shown in Fig. 7.3, indicates the presence of a carrier by lighting the lamp L which is mounted on the face-plate of the UN1/41. The unit also provides two relay-contact circuits which are used to sound an alarm and to mute the receiver output. The muting circuit is completed when the receiver is plugged into position, the necessary straps being provided in the bay wiring.

When a carrier is received, the a.g.c. line is driven from -12 volts toward zero potential and so the current through TR4 in the carrier-failure unit is reduced from its no-signal value. This drives the base of TR5 positive with respect to its

Instruction RS.2
Section 7

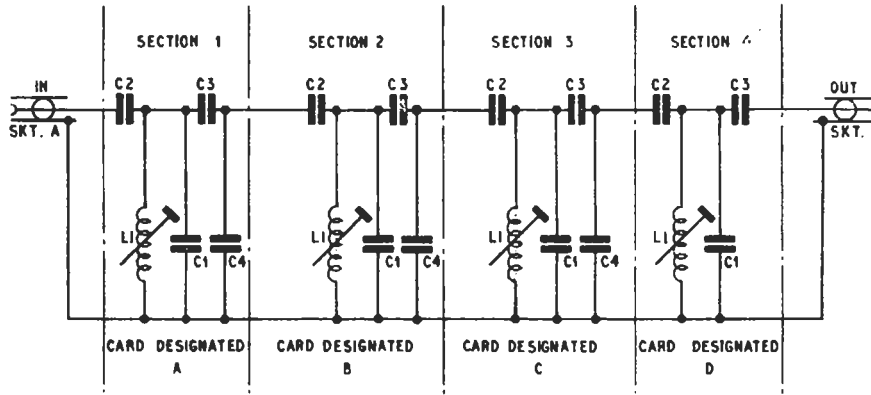

TABLE OF CAPACITORS

REF	A	B	C	D
C1	225pF	264pF	264pF	225pF
C2	52.3pF	36.3pF	30.9pF	36.3pF
C3	36.3pF	30.9pF	36.3pF	52.2pF
C4	136pF	136pF	136pF	

ALL INDUCTANCE ARE $7\mu\text{H}$

RSR/7/3

Fig. 7.2. I.F. Filter FL2/4 : Circuit

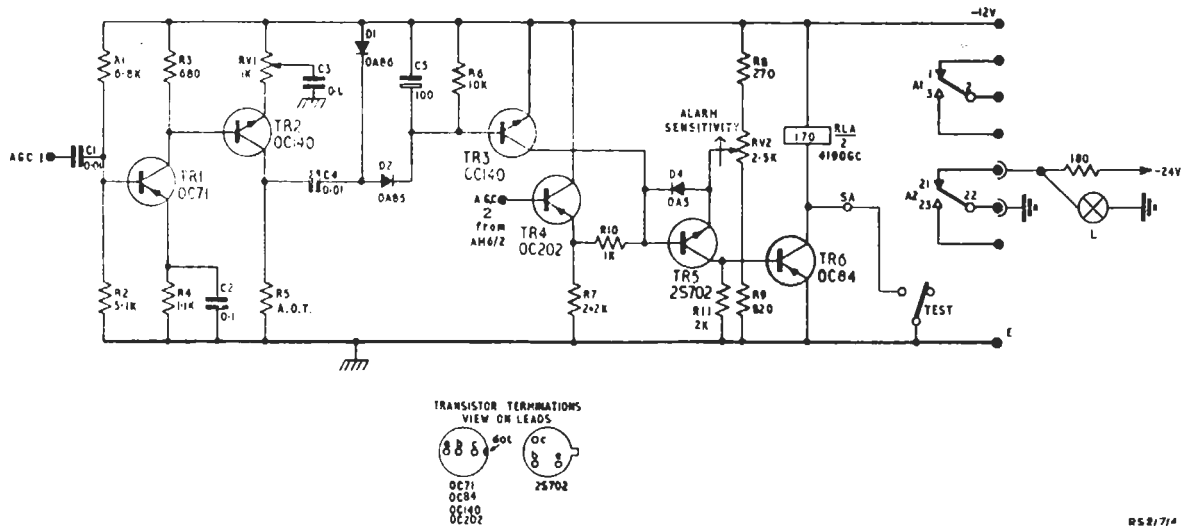

RSR/7/4

Fig. 7.3. Carrier Failure Unit UNI/32 : Circuit

emitter and so causes both TR5 and TR6 to draw current and thus operate the relay RLA. The purpose of D4 is to ensure that the reverse base-emitter rating of TR5 is not exceeded.

Transistors TR1, TR2 and TR3 are not used in these receivers and RV1 should be set to the minimum-gain position; i.e. fully anticlockwise.

I.F. Amplifier UN1M/56

This unit provides extra gain by forming a third cascode i.f. amplifier with the input transistor of the first i.f.-amplifier card in the UN1/41. The circuit is similar to that of the i.f.-amplifier cards but the value of R7 is reduced to 270 ohms to improve the stability.

deviation of ± 19 kHz, the audio output from the discriminator is -48 dB (with respect to 1 mW) or -45 dB for early models in which R5 is omitted. The output impedance is 600 ohms.

The unit also contains the arrangements for deriving the 12-volt supply, required by the r.f. and i.f. amplifiers, from either the mains or an external battery. The power-supply change-over is controlled by relay RLA which is held operated as long as power is available from the PS2/9. The 12-volt supply is obtained from the emitter follower TR1 the base of which is stabilised by two zener diodes connected in series; 6-volt zener diodes have a better temperature coefficient than 12-volt diodes.

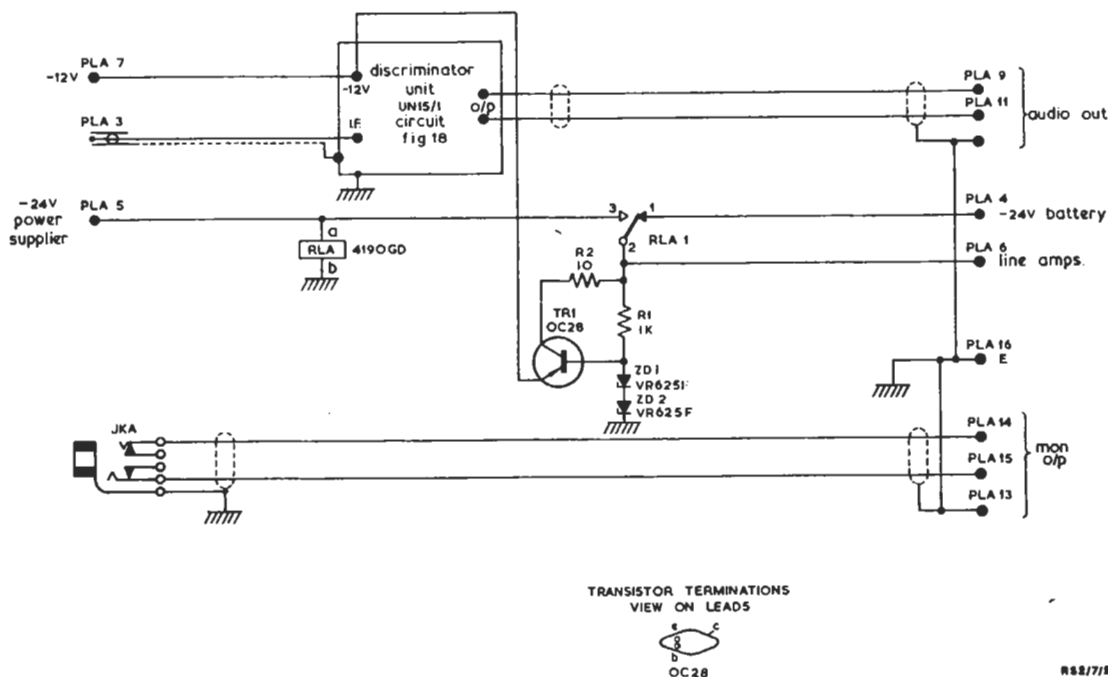

Fig. 7.4. Discriminator and Relay Unit UNI/52: Circuit

Discriminator and Relay Unit UNI/52 (Fig. 18)

The circuit of this unit is given in Fig. 7.4 but details of the Foster-Seeley discriminator are shown in Fig. 18. The diodes and their load resistors are connected so that the difference current flows in the small common resistor R18, thus providing the inverse of the conventional Foster-Seeley circuit (in which the difference voltage is applied to a large shunt resistor). At a

A monitoring jack, mounted on the front panel of this unit, is fed from the AM7/2 audio amplifier.

Maintenance

Routine maintenance on the receiver is unnecessary. Re-alignment of the receiver is not easy without sweep-frequency equipment and so, if faults occur which cannot be eliminated simply and quickly, the faulty unit should be returned to

Instruction RS.2
Section 7

Equipment Department.

Gain

The gain of the receiver can be checked by measuring the voltage on the a.g.c.2 line (with respect to chassis) for different levels of input signal. The figures shown in Table I should be obtained; higher voltages than those shown indicate a loss of gain for which the most likely cause is misalignment.

TABLE I

Input to Receiver	Voltage on a.g.c. line	
	Without UN1M/56	With UN1M/56
0	8.3	7.8
60 μ V	—	5.4
200 μ V	5.4	5.0
300 μ V	5.2	—
400 μ V	5.1	4.5
1 mV	4.6	4.0
2 mV	4.1	3.6
20 mV	3.4	—

Discriminator and Limiter

The alignment and operation of these circuits can be checked as follows. Connect a f.m. signal generator, such as the Marconi TF 995A, to the aerial socket. Modulate the generator with a 1-kHz signal to a deviation of ± 20 kHz and adjust the output level to 200 μ V.

Set the gain control of the AM7/4 to give a gain of 50 dB. The receiver output, as measured on an amplifier detector, should be +15, ± 3 dB.

Vary the r.f. input signal between 15 μ V and 50 mV; the audio output signal should not change by more than a total of 1.5 dB.

Carrier Failure Circuit

Measure the voltage across the relay coil with the alarm sensitivity control (RV2) in both the maximum and the minimum positions. The readings should not exceed 0.2 volt and 9 volts respectively.

AIB 9/66

This drawing is the property of the British Broadcasting Corporation and may not be reproduced or disclosed to a third party in any form without the written permission of the Corporation.

NOTES

- Screening Boxes BX1/4 indicated thus
- UNI/39 plug connections

1	input to UNI/37
3	I.F. output from MX1/3
5	oven not used
6	oven not used
7	-12v
14	oven control not used
15	oven control not used
2,4	spare
6-13	spare
16	E
- UNI/56 plug connections

1	output to UNI/41
3	input
6	A.G.C. 2
7	-12v
16	E
- UNI/41 plug connections

1	I.F. output
3	I.F. input
4	A.G.C.1 (not used)
5	Lamp
6	A.G.C.2
7	-12v
13	relay contacts
14	Lamp
15	-24v
16	E

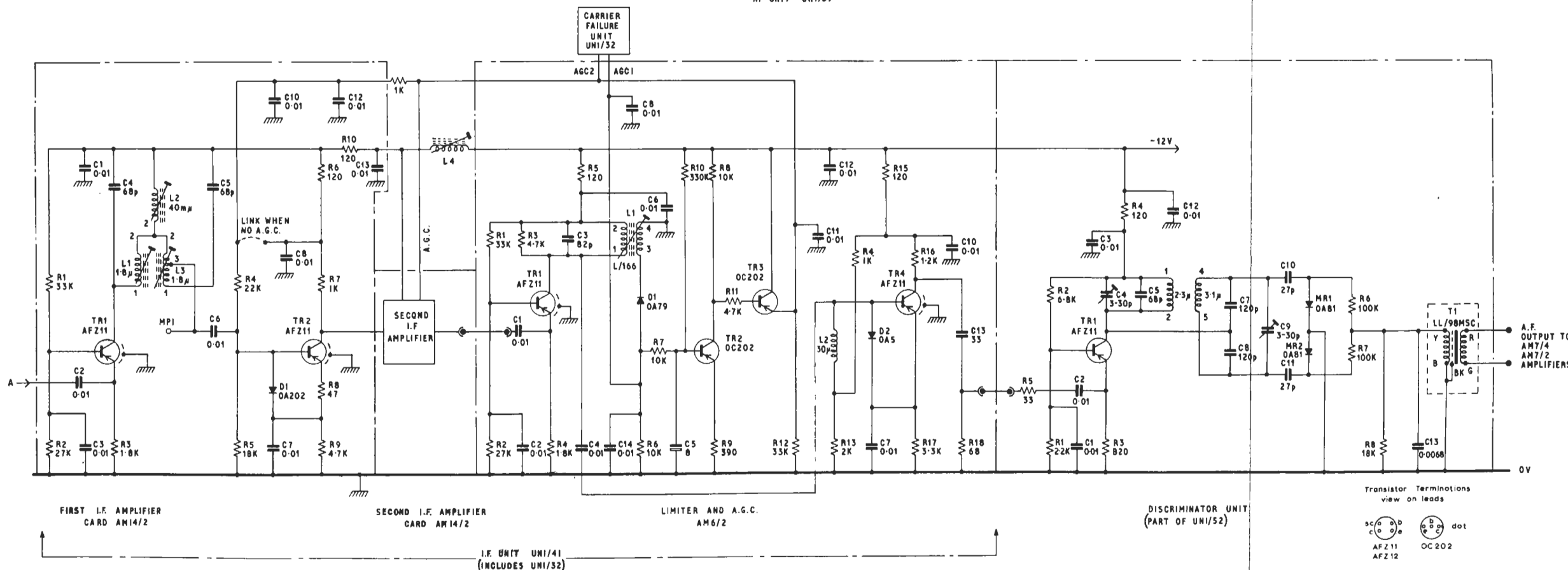
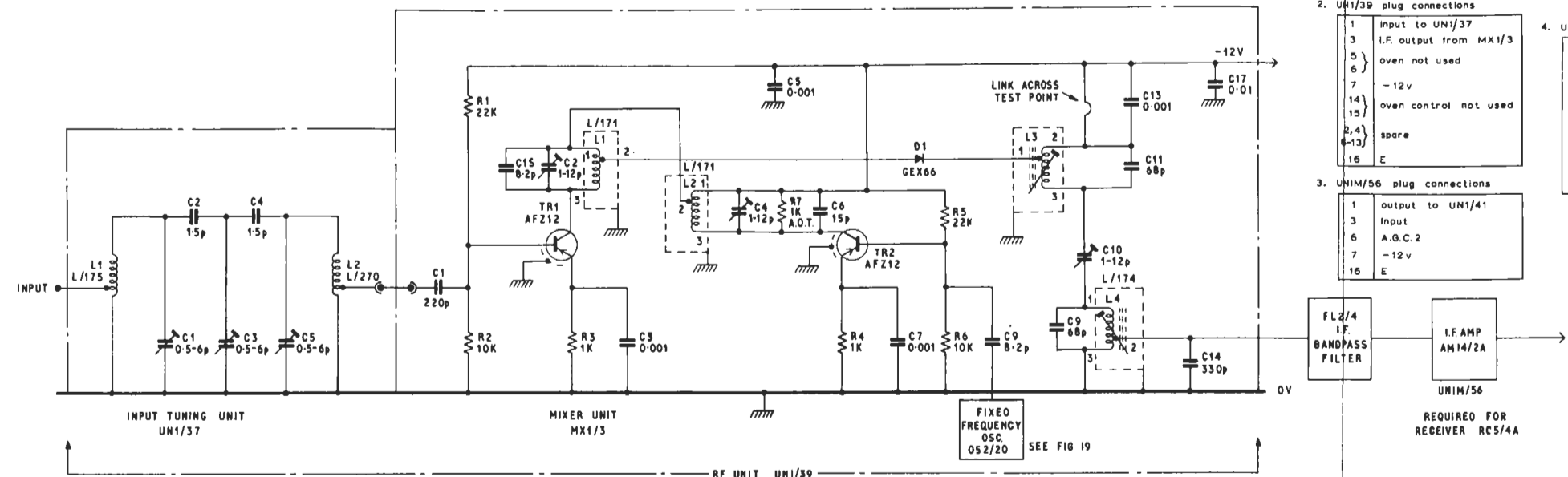

Transistor Terminations
view on leads

dot
 dot
 AFZ11
 OC202

VHF/FM REBROADCAST RECEIVER RC5/4 AND RC5/4A : CIRCUIT

FIG 19

This drawing is the property of the British Broadcasting Corporation and may not be reproduced or disclosed to a third party in any form without the written permission of the Corporation.

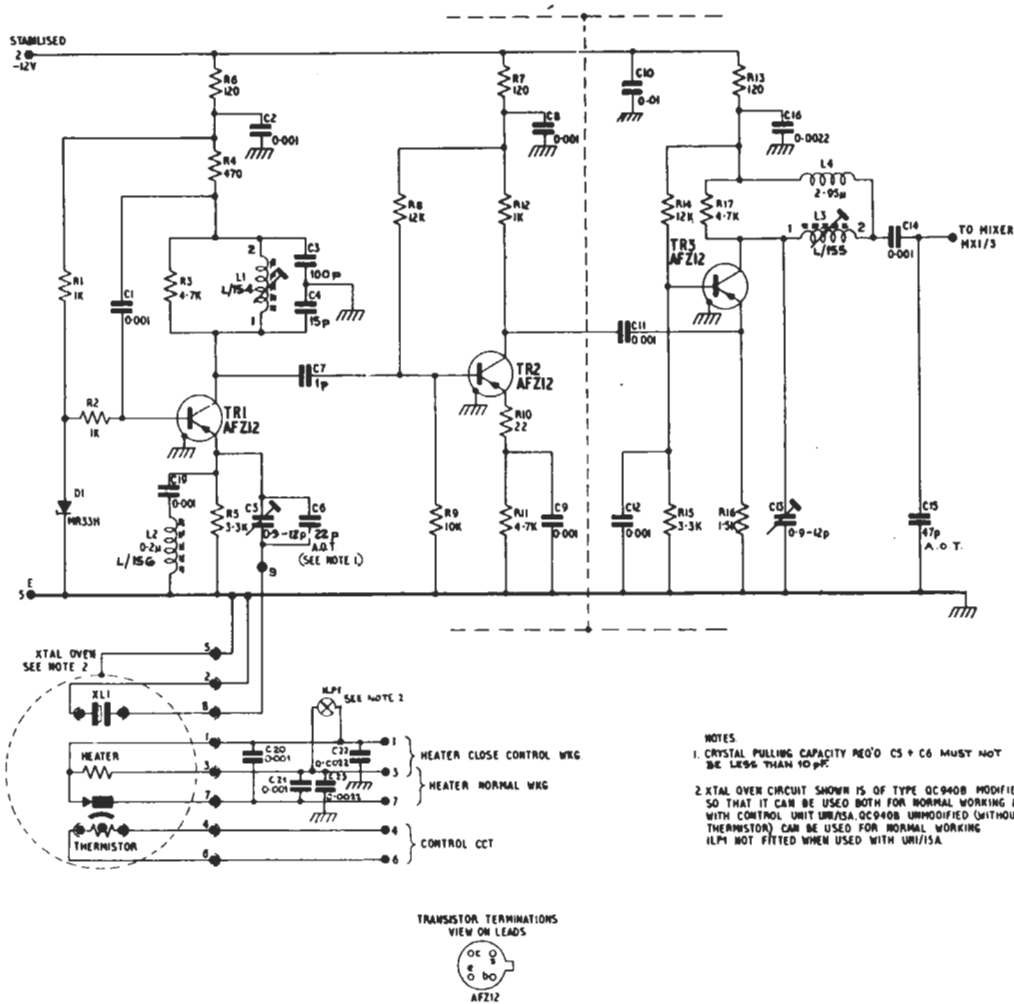

- NOTES
1. CRYSTAL PULLING CAPACITY REQ'D C5 + C6 MUST NOT BE LESS THAN 10 pF.
 2. XTAL OVEN CIRCUIT SHOWN IS OF TYPE QC940B MODIFIED SO THAT IT CAN BE USED BOTH FOR NORMAL WORKING & WITH CONTROL UNIT UR15A. QC940B UNMODIFIED (WITHOUT THERMISTOR) CAN BE USED FOR NORMAL WORKING. ALP1 NOT FITTED WHEN USED WITH UR15A.

TRANSISTOR TERMINATIONS
VIEW ON LEADS



CRYSTAL OSCILLATOR OS2/20 : CIRCUIT

This drawing is the property of the British Broadcasting Corporation and may not be reproduced or disclosed to a third party in any form without the written permission of the Corporation.

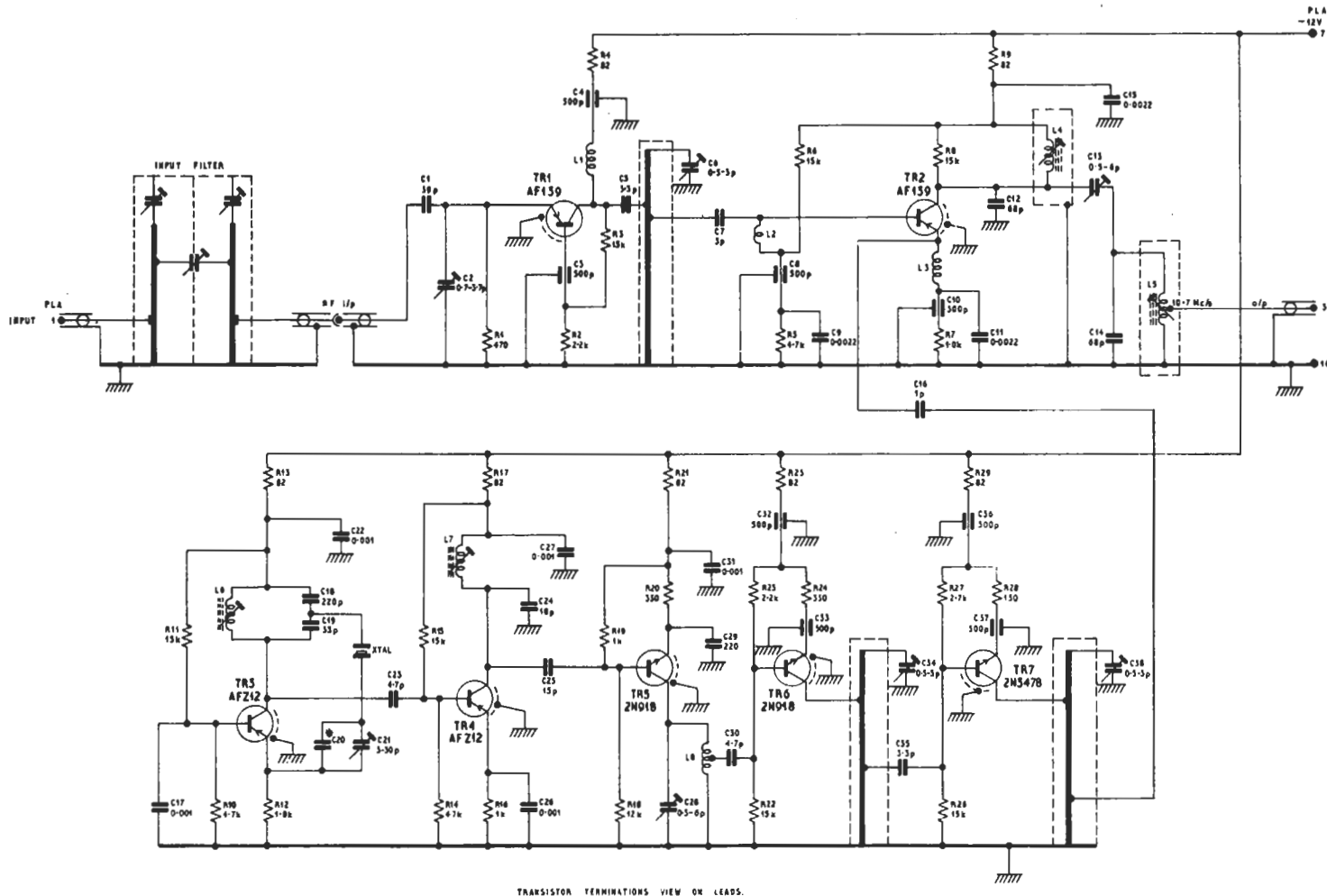

TRANSISTOR TERMINATIONS VIEW ON LEADS.

Note
* Crystal-pulling capacitance (C-20 + C-21)
will vary between 10 + 100p



BAND 4 / BAND 5 INPUT RF UNIT UNI/57 : CIRCUIT

FIG 20