

TEST PROGRAMME METER AMPLIFIERS TPM/3 AND TPM/3A

The Test Programme Meter Amplifier TPM/3 is designed for a general purpose programme volume measuring instrument and works on the same principle as the PPM/2. It has an additional amplifying stage preceding the normal PPM/2 circuit, and is designed for rack mounting.

steps of 4 db from + 8 db to - 48 db. The control consists of a 100 kilohms potentiometer having an accuracy of the order of $\pm 1\%$.

The main level control is followed by a two-stage resistance-capacitance coupled amplifier V1, V2. A small amount of current feedback is applied to

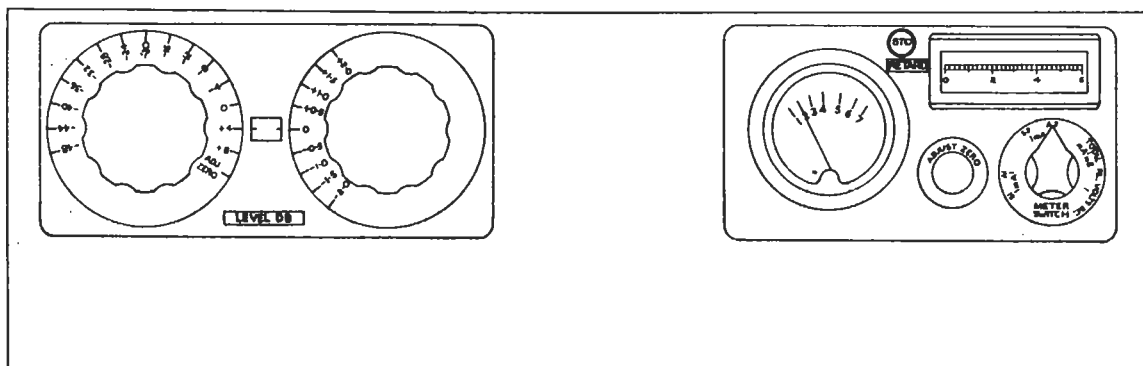

Fig. 11.3. Face Panel TPM/3 and TPM/3A

The sensitivity of the instrument covers a range from + 8 db to - 48 db in steps of 4 db, with an additional range of ± 2 db. Levels are read from the calibrated dials marked *Level DB*, a given level being the algebraic sum of the readings of the two calibrated dials when the programme meter reads 4.

Circuit Description (Fig. 11)

The input transformer has an impedance ratio of 1 : 10, giving an input impedance of 10 kilohms, with a reactance of 7 kilohms at 50 c/s. A connection to the 250-kilohm potentiometer, R1, is taken from the transformer secondary winding. This resistor is the *Adj. Sensitivity* control and is used during calibration for bringing the programme meter to its correct setting for a given input level.

The *Sensitivity* control is followed by the main *Level DB* control comprising the variable potentiometer PN/4A1, the dial of which is calibrated in

each of these stages independently, together with a large amount of voltage feedback over-all applied via R16.

The bias resistance for V1 takes the form of a calibrated resistance-capacitance network PF/1A, which is the second level control. It comprises two resistors, one of which is variable, so that the feedback is controlled by the setting of the variable resistor. The calibration of this resistor is from - 2 db to + 2 db in steps of .5 db. An additional resistor, R33, is included in series with the other leg of the shunt to obtain the correct value of mean bias.

It has been seen that the second level control, calibrated from + 2 db to - 2 db is actually connected in the feedback circuit. In the + 2 db position (i.e. minimum gain setting) maximum feedback is applied, reducing the gain of the amplifier to 50 db. In the - 2 db position (maximum gain setting) the feedback is reduced and the gain increased to 54 db.

Instruction S.4

Section 11

A small amount of current feedback is applied to V2 by dividing the bias resistance (R17, T30) into two sections and leaving one section, R17, uncoupled. Voltage feedback is applied to both V1 and V2 via R16.

The total feedback applied to the two-stage amplifier reduces its output impedance to a value suitable for feeding into the programme-meter circuit proper. In addition, the total feedback reduces the gain of the amplifying stages from 90 db to 54 db and improves the general stability of the amplifying circuit in relation to valve or h.t. supply changes.

The output impedance of the amplifier stage is 4 kilohms to 4.5 kilohms, according to the setting of the feedback potentiometer.

The amplifier stage feeds into the programme meter circuit, which is identical to that of the PPM/2. It comprises a double-diode rectifier, V3, feeding into a variable- μ pentode, V4, in the anode circuit of which is inserted the peak programme meter.

With no input signal, the anode current of V4 deflects the right-hand zero meter to the 'no signal' zero mark.

On the application of signal voltage to the input stage, the rectified output of V3 applies bias to V4, decreasing the anode current and reducing the left-hand deflection of the meter in proportion to the strength of the applied signal. For further details of this part of the circuit, see under PPM/2.

Performance

The frequency characteristics of the TPM/3 are such that for any setting of the main sensitivity control, a sensibly linear response is obtained for all frequencies between 50 c/s and 10 kc/s, maximum variation of level being of the order of ± 0.1 db. The sensitivity variation does not exceed ± 0.1 db for a change in h.t. volts from 300 to 250.

Meter

The meter used with the TPM/3 is identical to that described in the Instruction on the PPM/2.

If an external meter is used with the TPM/3, it must be placed in series with the existing meter, the wiring to be effected at tags 11 and 12, which are provided for this purpose. When no external meter is used, these tags will be shorted out. The meter connections are, of course, at h.t. potential.

Valve Data

Stage Valve	Anode	Screen	Filaments	
	Current mA	Current mA	Volts	Amps.
1 AC/SP3B	3.0	1.1	4	1
2 AC/SP3B	3.1	1.1	4	1
3 D41	—	—	4	0.3
4 AC/VP1	—	—	4	0.65

Total Feed, 15 mA.
Neon Type Osram S1.
H.T. supply, 250 or 300 V.
L.T. supply, 4 V. a.c. or 6 V. d.c.

General Data

Input Impedance, 10,000 Ω .

Potentiometers

Level db (Coarse): Painton PN/4A1, 100 k Ω .

Level db (Fine): Painton PF/1A1.

Adjust Sensitivity: Morganite Stackpole MNAP 25450, 250 k Ω .

Adjust Zero: Morganite Stackpole MNAP 50350, 50 k Ω .

Adjust Law: Morganite Stackpole MNAP 10250, 1 k Ω .

Zero Balance: Morganite Stackpole LHAP 50250, 5 k Ω .

Retard Key, P.O. No. 228.

Meter Switch, Yaxley Type H, 2-bank, 9-position.

Operation

- (1) Switch on the mains unit about 10 minutes before use.
- (2) Set main *Level DB* control to *Adj. Zero* position and adjust zero by means of the *Adj. Zero* control to the 'no signal' zero mark.
- (3) Plug the output of the CAL/1 to the input of the TPM/3. Set level controls to zero. The meter should read 4. If it does not, adjust to 4 by means of the *Adj. Sens.* control.
- (4) Set main level control to + 8 and - 8. The meter should read 2 and 6 respectively. If not proceed as follows:—
 - (a) To open scale (i.e. meter reads above 2 and below 6):
 - (i) Unplug input jack. Set main level control to *Adj. Zero* (extreme right) position.
 - (ii) Turn *Adj. Law* control until meter reads above the zero mark.

- (iii) Re-adjust to zero by means of *Adj. Zero* control.
- (iv) Repeat tests 3 & 4, repeating *Adj. Law* adjustment if necessary until correct conditions are obtained.

- (b) To close scale (meter reading in test (4) below 2 and above 6).

Proceed as under (a) except that in (ii) meter is set to read *below zero*. Some repetition may be necessary in these tests, but the error should be reduced to a minimum by a process of elimination.

Recalibration after Neon and Valve Replacements

Replacement of the rectifier D41 should not affect the calibration in any way, but after replacement of a neon tube or AC/VP1, the zero and law calibration including 'zero balance' must be checked and adjusted. For this purpose it is necessary to provide a means of varying the supply voltage, and a tapped transformer or 'Variac' should be interposed between the mains-supply socket and the mains unit feeding the programme meter. A variation from the normal working voltage down to about 15 per cent below normal (e.g., from 240 volts down to 200 volts) should be obtainable.

The procedure is as follows :

- (i) Adjust the mains-unit input voltage to the nominal value, e.g., 240 volts,* and with the *Zero Balance* control fully clockwise (i.e., neon returned to earth), line up the programme meter in the usual way.
- (ii) Set the *Zero Balance* control to its mid position, and restore the meter reading to zero by means of the *Adjust Law* control.

- (iii) Reduce the mains-unit input to 200 volts.* If the meter reading rises, the *Zero Balance* control has not been rotated far enough. If the reading falls, the control has been turned too far.
- (iv) Restore the mains-unit input voltage to normal*, rotate the *Zero Balance* control a small amount in the direction as indicated in (iii) above, and re-set the meter zero by means of the *Adjust Law* control.
- (v) Reduce the mains-unit input volts once again to 200*, and proceed as above, until varying the voltage between 240 and 200 produces no change in the meter zero reading.
- (vi) The *Zero Balance* control should be left in the position thus found unless either the neon tube of the AC/VP1 valve has to be replaced.

*Note:—Each time the a.c. voltage is varied, about 20 seconds should be allowed to elapse before proceeding with the next step to allow the consequent variation in valve-heater voltage to take effect.

Changes : TPM/3 and TPM/3A

TPM/3. Units having serial numbers below 207 are fitted with a retard-relay L34.43, operating from a 24-volt supply ; units having serial numbers 207 and above are fitted with relay 3/102 which may be operated from either a 24-volt or a 50-volt supply.

TPM/3A. The only difference between this unit and the *TPM/3* is that the retard-relay is an RD 2500. This relay operates from a 50-volt supply.

ISSUE	AMENDMENT
2	C3 WAS 0.2μF R16 WAS AT JUNCTION OF C8 & R11 R34 & R35 ADDED TERMINAL 5 CENTRE TAP OF T2 ADDED C10 REMOVED KEY No228 REWIRED T2 WAS LGG/IOISH FEED METER REPLACED BY JACK NOTE 1 ADDED R21 WAS ADJUST ZERO & R24 WAS ADJUST LAW R36 ADDED
3	INPUT CCT MODIFIED

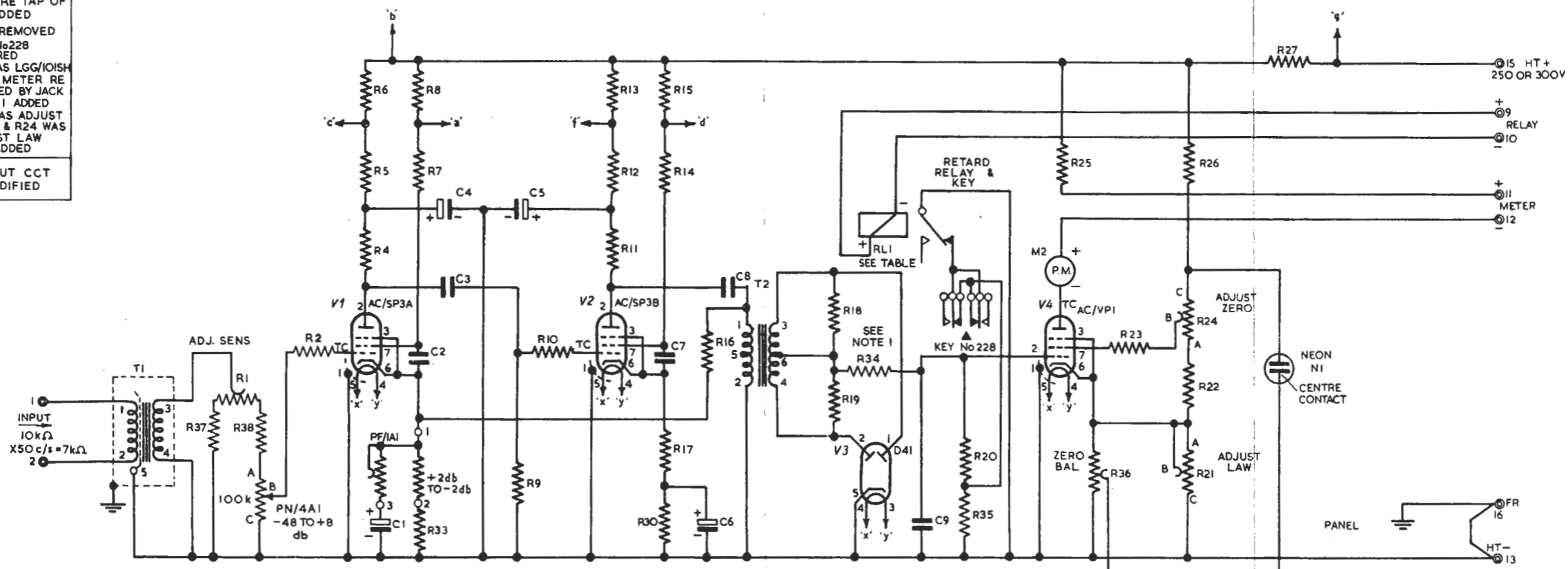

COMPONENT	VALUE	RATING	COMPONENT	VALUE	RATING
C1	250 μF	25V WKC CE26C	R14	160 000 Ω	0.5 WATT
C2	2 "	B2	R15	333 "	"
C3	0.25 "	CP47 S	R16	300 000 "	0.25 "
C4,5	1.6 "	CE15129	R17	300 "	0.5 "
C6	250 "	25V WKC CE26C	R18,19	250 000 "	0.25 "
C7	2 "	B2	R20	5MΩ	"
C8	1.0 "	350V WKC CP91N	R21	1000 Ω	"
C9	0.2 "	CP46 S	R22	100 000 "	1 "
R37	130 000 Ω	"	R23	50 000 "	1 "
R38	33 000 "	"	R24	50 000 "	"
R1	250 000 Ω	"	R25	100 000 "	1 "
R2	5 000 "	0.25 WATT	R26	50 000 "	1 "
R4	60 000 "	1 "	R27	5.26 "	"
R5	3 000 "	0.25 "	R28	3900 "	P40I
R6	333 "	"	R29	2 "	3BI
R7	180 000 "	0.5 "	R30	300 "	0.25 "
R8	333 "	"	R31,32	10 "	"
R9	300 000 "	0.25 "	R33	50 "	1 "
R10	5 000 "	"	R34	3KΩ	"
R11	50 000 "	1 "	R35	40MΩ	"
R12	3 000 "	0.25 "	T1	1:3.16	LC/75A
R13	33.3 "	"	T2	1:2	LGG/ISH
			R36	5000 Ω	LHNAP

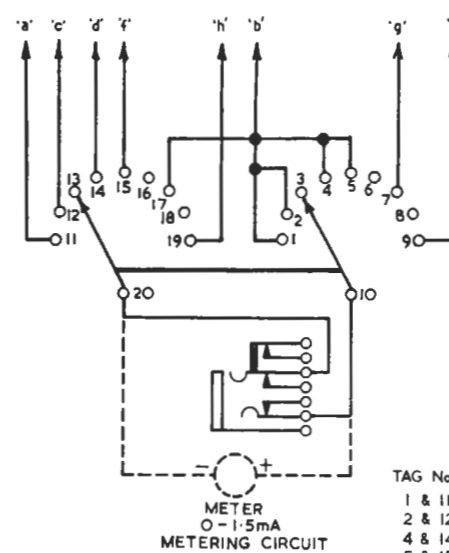

TAG Nos RE

1 & 11	— 51mA
2 & 12	— 1mA
4 & 14	— 52mA
5 & 15	— A2mA
7 & 17	— TOTAL mA X 5
9 & 19	— FIL VOLTS DC

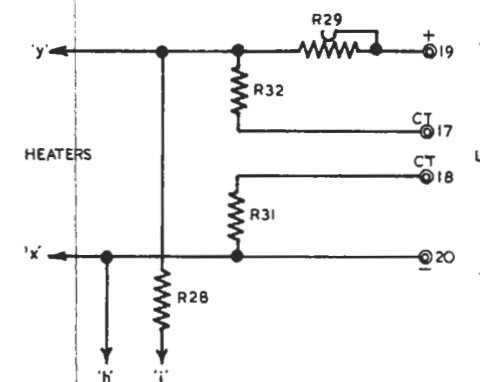

UNIT	SERIAL Nos	RELAY TYPE	WORKING VOLTAGE
TPM/3	BELOW 207	L34.43	24
TPM/3	207 ONWARDS	3/102	24 OR 50
TPM/3A		RD2500	50

NOTE 1 R34 TO BE ADJUSTED ON FLICK TEST IF NECESSARY

TEST PROGRAMME METER AMPLIFIER TPM/3 & TPM/3A

54055A/5.4/AJP

SECTION 11

PEAK PROGRAMME METERS & AMPLIFIERS

PEAK PROGRAMME METER PPM/2

The Peak Programme Meter Amplifier, PPM/2, is rack mounted and designed to work in conjunction with a peak programme meter for the measurement of testing level or programme volume.

The PPM/2 is normally used for measuring levels

the meter. The control is labelled *Adj. Law.*

A neon stabiliser is connected between the screen-grid circuit of V3 and a tapping point on the valve cathode resistance. The action of the neon, in addition to stabilising the screen-to-cathode voltage, is as follows. When the mains-supply voltage and hence the h.t. voltage varies, the

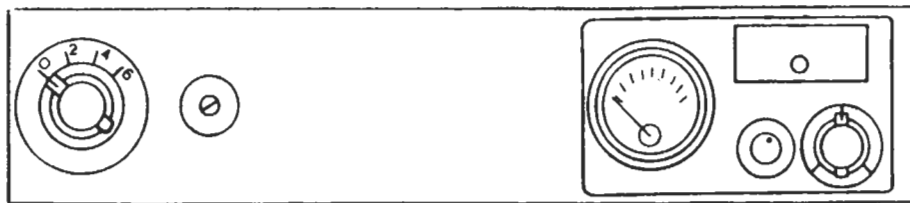

Fig. 11.1. Face Panel PPM/2

of the order of zero db, and has limited pre-set gain control for calibration purposes. Arrangements are made for dealing with levels of + 10 db, + 14 db, or, in special cases, - 23 db.

Circuit Description (Fig. 7)

The PPM/2 comprises a single-stage amplifier, V1, transformer coupled to a double-diode detector, V2, the output of which feeds into a pentode output stage, V3, in the anode circuit of which is connected the peak programme meter itself. The signal input to the first stage is fed through a step-up transformer, T1, which has an impedance ratio of 1 : 10.

10 db negative voltage feedback is applied in this stage from the centre point of R18 and R19, connected across the output of V1.

Where the PPM/2 is mounted on a recording programme input bay, the feedback circuit is omitted in order to obtain increased gain for dealing with the low line-up level of - 23 db.

The screen-grid volts supply of V3 is made variable by means of R25 in order to allow adjustment of anode current to maintain correct 'no signal' zero on the meter. R25 is labelled *Adj. Zero.*

The bias resistance, which is not decoupled, is also variable by means of R23. This arrangement permits adjustment of the cathode bias to allow the valve to work on a suitably curved part of its characteristic for correct logarithmic operation of

current through the neon changes, and as this current also flows through part of V3 cathode resistance, the valve bias is altered in such a way as to oppose the change in anode current which would otherwise occur, and by a suitable choice of values the zero drift may be eliminated over a given range. The point on the cathode resistance at which the neon current is injected can be varied by the *Zero Balance* control, R38, and this control must be adjusted with reference to the particular combination of AC/VP1 valve and neon tube in use.

The working principles of the PPM/2 are simple. The applied signal is amplified by V1 and rectified by V2, the rectified signal being applied to the grid of V3 in the form of additional bias. Since the meter is of the right-hand zero type, it has maximum left-hand deflection when this bias is zero, i.e. at 'no signal' input.

As soon as a signal is applied to V1, bias is applied to V3 via V2 and R22 and the anode current of V3 is reduced, causing a right-hand deflection of the meter in logarithmic proportion to the bias voltage, which is, of course, dependent upon the input voltage to the amplifier.

Meter Registration Speed

The meter registration speed is dependent upon the value of C5 and the total series impedance, which includes R33, the reactance of T2 and the

Instruction S.4
Section 11

anode impedance of V2. The time constant of the charging circuit is 2.5 milliseconds, and the instrument therefore reads 63% of the peak value of a square pulse having this duration; for a 4-millisecond pulse the reading is 80% of peak, or 2 db low. The meter thus indicates the instantaneous value of peak programme volume to a sufficient degree of accuracy to permit the uniform control, without serious overloading, of all programmes irrespective of their dynamic characteristics.

The meter return time, which is governed by the value of C5 and its discharge resistor, R22, is 3 seconds for the 26-db fall-back from 7 to 1 on the scale. (It is to be noted that, although the scale markings represent 4-db intercepts in general, the first intercept between 1 and 2 is 6 db.)

To facilitate the comparison of different meters working on the same programme, provision was made for increasing the return time by inserting the resistor R37 in series with R22 by operation of the relay L34.43. This method of comparison has now been superseded, the present method being to integrate the peaks over a period of about a second and thus to read 'average' peaks. An external meter is used, this being connected in series with a 10-k Ω resistor and the combination shunted by an 80- μ F or 100- μ F capacitor. The arrangement does not affect other series instruments fed from the same programme-meter amplifier, and for normal peak readings the capacitor can be removed from across the PPM meter and discharged through the 10-k Ω resistor by the operation of a switch.

Valve Data

Valve	Anode Current mA	Screen Current mA	Fil. Volls	Fil. Amps.
Stage 1, AC/SP3B	7	3	4	1
Stage 2, D41	—	—	4	0.3
Stage 3, AC/VP1	—	—	4	0.65

Total Feed, 10 mA, approx.
H.T. Supply, 300 V or 250 V.
L.T. Supply, 4 V a.c. or 6 V d.c.

General Data

Neon Stabiliser, BBC S1.
Pilot Lamp, P.O. No. 2, 4 V.
Potentiometers

Adjust Sensitivity : Morganite Stackpole MNAP
10450, 100 k Ω .

Adjust Zero : Morganite Stackpole MNAP
50350, 50 k Ω .
Adjust Law : Morganite Stackpole MNAP
10250, 1 k Ω .
Zero Balance : Morganite Stackpole LHAP
50250, 5 k Ω .

Input Impedance, 10 k Ω .

Switches

Check Attenuator, Yaxley B, s.p., 4-position.
Meter, Yaxley A, 2-bank, 9-position.

Operation

The PPM/2 can be used for input levels of 0, + 10 or + 14 db. Adjustment for the required normal level is effected by soldering the two flexible leads on the input attenuator to the appropriate termination tags, which are accessible by removing the front cover. The meter is calibrated and adjusted to read normal level at 4, and maximum peak level at 6.

Calibration. To ensure stability the amplifier should be switched on at least ten minutes before calibration.

- (1) Check 'no signal' zero with no input.
- (2) Connect the output of the CAL/1 to the input and set the calibrating switch to 4 (normal). The meter should now read 4. If it does not, adjust to 4 by means of the sensitivity control.
- (3) Set the calibrating switch to 2 and 6 in turn. The meter should read 2 and 6 respectively. If it does not, proceed as follows :—

- (a) To 'open' scale (i.e. if meter reads above 2 and below 6).
 - (i) Unplug the input jack.
 - (ii) Turn *Adj. Law* control till the meter reads between 0 and 1.
 - (iii) Readjust to zero by means of *Adj. Zero* control.
 - (iv) Plug up input jack and repeat 2 and 3.
- (b) To 'close' scale (i.e. if meter on test 3 reads below 2 and above 6). Proceed as in (a) except that under test (ii) set the meter to read *below* 'no signal' zero by means of *Adj. Law* control.

Recalibration after Neon and Valve Replacements. Replacement of the rectifier D41 or of the valve AC/SP3 should not affect the calibration in any way, but after replacement of a neon tube or AC/VP1, the zero and law calibration including 'zero balance' must be checked and adjusted. For this purpose it is necessary to provide a means of varying the supply voltage, and a tapped transformer or 'Variac' should be interposed between

the mains-supply socket and the mains unit feeding the programme meter. A variation from the normal working voltage down to about 15 per cent below normal (e.g., from 240 volts down to 200 volts) should be obtainable.

- (i) Adjust the mains-unit input voltage to the nominal value, e.g., 240 volts, and with the *Zero Balance* control fully clockwise (i.e., neon returned to earth), line up the programme meter in the usual way.
- (ii) Set the *Zero Balance* control to its mid position, and restore the meter reading to zero by means of the *Adjust Law* control.
- (iii) Reduce the mains-unit input to 200 volts. If the meter reading rises, the *Zero Balance* control has not been rotated far enough. If the reading falls, the control has been turned too far.

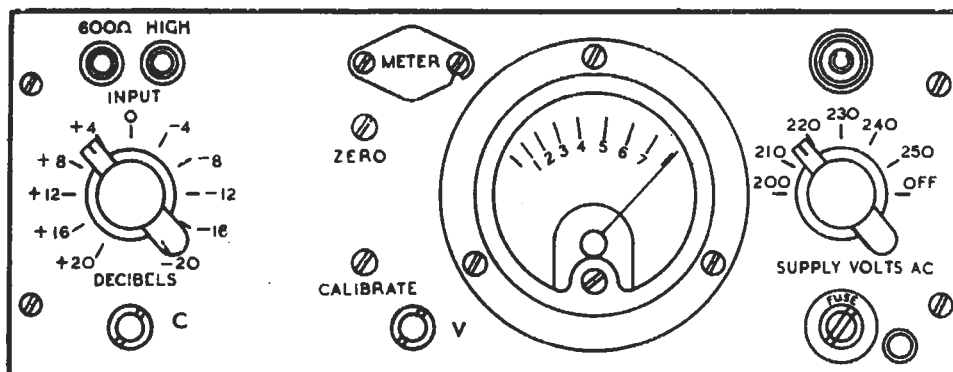

Fig. 11.2. Face Panel PPM/6

- (iv) Restore the mains-unit input voltage to normal, rotate the *Zero Balance* control a small amount in the direction as indicated in (iii) above, and re-set the meter zero by means of the *Adjust Law* control.
- (v) Reduce the mains-unit input volts once again to 200, and proceed as above, until varying the voltage between 240 and 200 produces no change in the meter zero.
- (vi) The *Zero Balance* control should be left in the position thus found unless either the neon or the AC/VPI has to be replaced.

Each time the a.c. voltage is varied, before proceeding with the next step about 20 seconds should be allowed for the consequent change in valve-heater voltage to take effect.

General Note

Some modification to these instructions is necessary where the PPM/2 is used on recording or transmitter programme input bays.

PEAK PROGRAMME METER PPM/6

The portable Peak Programme Meter PPM 6 (Fig. 11.2) is a mains-operated measuring instrument which can be used in any apparatus room having a 200-250 volt, 50-c/s a.c. mains supply. It is particularly convenient for taking disk-reproducing response measurements and also for use in conjunction with the portable oscillator PTS/9. In both cases, the use of special tie lines to an A.C. Test Bay is avoided.

The PPM/6 employs the basic circuit used in the PPM/2 and TPM/3. The construction is modified to reduce physical dimensions and make the unit self-contained.

Circuit Description (Fig. 8)

The circuit consists of a single amplifying stage using an AC/SP3B, connected for triode working, followed by the standard double diode and variable-mu pentode circuit of the PPM/2. The normal input circuit has high impedance (12.5 kilohms) but the provision of a second input jack gives a 600-ohm input when required. A push-button key *C* is interposed between the input jacks and the input transformer. When this key is depressed, a 50-c/s calibrating signal, obtained from the mains supply, is applied to the input of the first valve.

The amplifier gain-control consists of an attenuator, calibrated in steps of 4 db to cover a level range from +20 to -20 db. Measurement of peak programme volume is obtained by setting this

Instruction S.4
Section 11

attenuator to the stop which gives a reading of 6 on the meter, the volume being indicated by the attenuator switch position. Intermediate readings can be obtained by interpolation, the meter being calibrated in 4-db divisions. Similarly, the range of measurement may be increased within the limits of the meter scale.

The accuracy of the meter readings depends upon the correct initial setting of the calibrating potentiometer.

When the plunger key *V* is depressed, the meter is connected in series with R18 across the mains transformer filament winding. The value of R18 is adjusted on initial test so that the meter reads 4 when the primary of the mains transformer is worked on the tapping corresponding with the mains supply voltage.

To ensure that a meter reading of 4 indicates an amplifier input signal of zero db, a special calibrating circuit is provided. When the resistor R5, in the l.t. supply circuit, is switched across the input transformer T1 by depressing key *C*, the 50 c/s voltage across R5 produces zero level across the primary of T1. The calibrating resistor R2 in the anode circuit of V1 is then adjusted, with key *C* depressed, until the meter reads 4.

Valve Data

Valve	Anode Current mA	Fil. Volts	Fil. Amps.
Stage 1, AC/SP3B	3	4	1
Stage 2, D41	—	4	0.3
Stage 3, AC/VP1	Variable	4	0.65
Rectifier UU.6	—	4	1.4

General Data

Neon Lamp N1, BBC S1.

Neon Lamp N2, BBC S3.

Decibel Switch, Yaxley Type A, 1-bank, 11-position.

Supply Volts Switch, Yaxley Type A, 1-bank, 7-position.

Potentiometers

Calibrate :	Morganite Stackpole LHAR 25350, 25 kΩ.
Adjust Zero :	Morganite Stackpole LHAR 50350, 50 kΩ.
Adjust Law :	Morganite Stackpole LHAR 10250, 1 kΩ.

Zero Balance : Morganite Stackpole LHAP
50250, 5 kΩ.

Operation

- (i) Set the switch marked *Supply Volts A.C.* to the 'Off' position and connect the mains. Turn the switch to the stud position 250. Observe the indicator lamp immediately above. If it does not light, switch off at once—the mains may be d.c. and will burn out the mains transformer.
- (ii) If the lamp lights up, depress the key marked *V* and adjust the supply switch until the meter reads 4 as nearly as possible.
- (iii) Release the key and allow a few minutes for warming up. Adjust the screwdriver control marked *Zero* until the needle rests on the white zero mark at the left end of the scale.
- (iv) Set the attenuator switch marked *Input Decibels* to zero and depress the key marked *C*. The meter should deflect to 4; if it does not, adjust the *Calibrate* control.

Maintenance

If the neon lamp N1 or the valve V3 has to be changed, it will be necessary to check the 'law' and 'zero balance' of the meter.

To check the 'law,' proceed as follows :

- (a) Carry out tests (i) to (iv) as outlined above.
- (b) With the key marked *C* still depressed, switch the attenuator to positions marked +8 and -8 when the meter should read 2 and 6 respectively. If adjustment is necessary, proceed as follows :—
- (c) To 'open' scale.
Release key and adjust *Law* control to bring the needle *forward* slightly.
Readjust zero by means of the *Zero* control. Then check as in (a) above.
- (d) To 'close' scale.
Proceed as in (c) above, except that the needle is first set *back* from the correct zero by means of the *Law* control.

To check the 'zero' balance' :—

- (1) Connect a tapped transformer or 'Variac' between the mains-supply socket and the a.c. input to the meter. Then set the *Supply Volts A.C.* switch and Variac to the nominal voltage of the supply, and with the *Zero Balance* control fully clockwise, carry out operations (iii) and (iv) and (b) to (d) above.
- (2) Now proceed as for the PPM/2 as described under *Recalibration after Neon and Valve Replacements*, operations (ii) to (vi).