

JK BISTABLE UNITS UN9/528 AND UN1/535

General Description

These units are edge-triggered JK bistables¹ with separate feedback and bias inputs. The circuit of both bistables is given in Fig. 1 and the symbol defines their operation in positive logic.

Feedback Input Gating

The *Feedback* input of the bistable unit is often fed via a capacitor and resistor as shown in Fig. 2. This input circuit can be represented as an AND gate. The resistive input *x* is usually fed from the collector

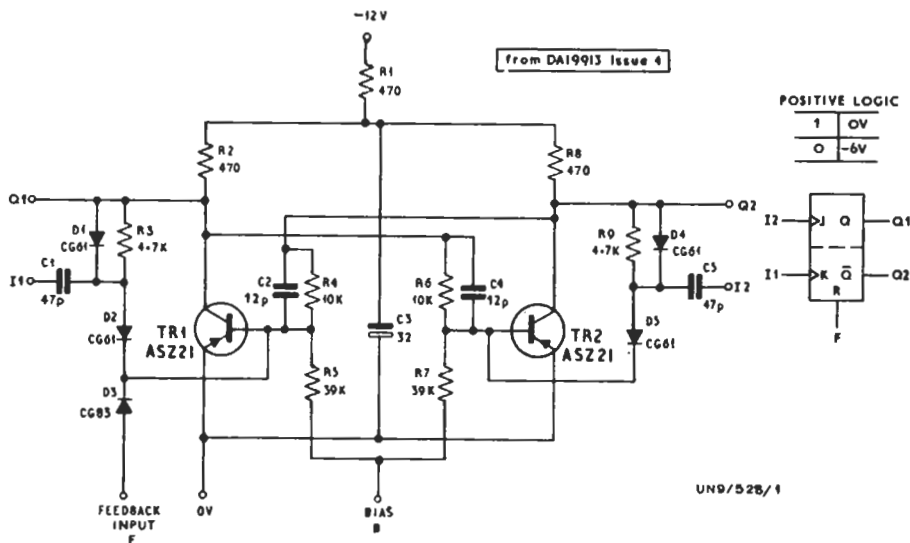

NOTE. In a second version of the circuit all five diodes are type 1N4148. In a third version of the circuit the transistors are type 2894A, all diodes are type 1N4148 and C2, C4 are 22pF. No other combinations of components should be used.

Fig. 1. Circuit Diagram and Symbol for the JK Bistables

The truth table for JK operation is given in Table 1; level 1 on the *Feedback* input resets the Q_2 output to level 1, irrespective of the other signal inputs. The Bias input is normally connected to level 1. Signal inputs to I_1 and I_2 must have rise-times of less than 60 ns to operate the bistables.

Table 1

J	K	Q_{n+1}
0	0	Q_n
0	1	0
1	0	1
1	1	\bar{Q}_n

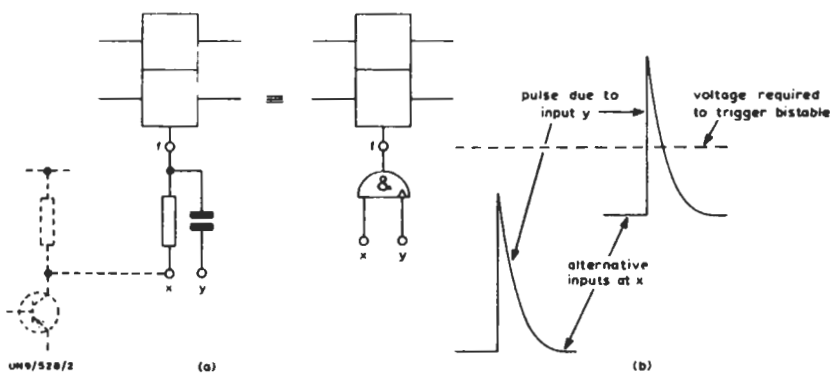

Fig. 2. And Gate Input Circuit

pulse is sufficient to trigger the feedback input as shown in Fig. 2(b).

References

1. *Switching Circuits and Logic*; Instruction GP.1.

The UN9/528 and UN1/535 are electrically identical and are constructed from discrete components in printed wiring boards 2 inches by $1\frac{7}{8}$ inches (UN9/528) and $4\frac{5}{8}$ inches by $1\frac{7}{8}$ inches (UN1/535). A power supply of -12 V, 13 mA is required.

MJR 10/67
 Revised RDH 8/72
 SWA 3/73